

# INGO



# MA

OVERVIEW 26/27

# URER

COLLEC  
TION

EDI  
TION

Click to open  
the category index

NEW CREATIONS<sup>17</sup>  
FLOOR<sup>39</sup>  
TABLE<sup>61</sup>  
WALL<sup>101</sup>  
HANGING & CEILING<sup>141</sup>  
SYSTEMS<sup>225</sup>  
MAMO NOUCHIES<sup>239</sup>

Click on the category name  
to go to the index by model

NEW

Nalum  
Shhh!  
Jasna Kuchnia  
Erupe Springsteel  
Strange Little Thing

CREA  
TIONS

Click on the name to open  
the product details page

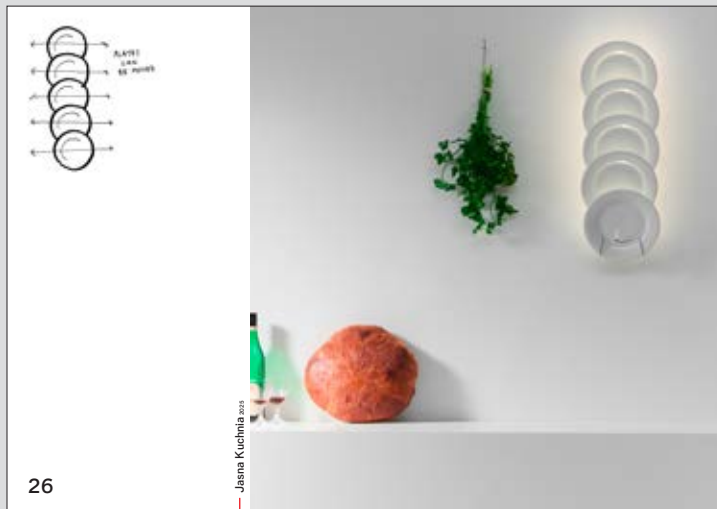

Click on the name to open  
the technical information page

COLLEC  
TION

EDI  
TION

**COL**

**LECTI  
ON**

**MINING**

**MANUFACTURE**

NO

REFER

# THE ART OF LIGHTING DESIGN

By Deyan Sudjic

Ingo Maurer changed the way that we see light. He was a designer who worked with technology and used craft skills to produce some of the most inventive and original lights of our times. They are playful, delicate and full of the kind of emotional expression that makes them much more than simple utilitarian objects.

At the same time, Ingo built a company that was partly the studio of an artist, part workshop and part research laboratory to make his designs. It is still flourishing today as part of the Foscarini group. Inspired by the work of the founder, the design team in Munich has maintained the company's reputation for creative innovation with a range of new products. It is unique in the world of lighting manufacturing, closer to a couture atelier than a factory production line. Ingo understood the sense of personal interaction that we can have with domestic lights. It is an interaction that comes from the impact that the quality of light has on our emotional mood, and the reassurance that comes from a tactile switch that puts us in command of it.

Born in Germany in 1932, he began his career working as a graphic designer in the USA, before going home to Munich and opening his workshop there. When Ingo started designing, electric light was still less than a century old. Unlike the chair, which mankind has been making for thousands of years, the taxonomy of lighting: ceiling lamp, floor lamp, desk light and so on, had only recently taken shape.

Joseph Swan and Thomas Edison had filed their respective patents for filament light bulbs in vacuum filled glass tubes at the end of the 1870s. Early electric light fittings were patterned on candles and oil or gas lamps, until under the influence of the Bauhaus they took on a more simplified form.

Ingo Maurer began his career as a lighting designer in 1966 with *Bulb*, his tribute to Edison, a surrealistic visual pun which put a light bulb inside a giant bulb-shaped glass enclosure, an idea that San Francisco's Museum of Modern Art has compared to a Claes Oldenburg sculpture. It was designed at a time when the light fitting was still seen as either frankly functional, or else cosmetically decorative. *Bulb* was a much more subversive idea, it suggested that wit could be part of the equation.

Ingo Maurer explored lighting free from the weight of precedent. Since there was no 'right' way to make a light, Ingo could invent his own archetypes, of which perhaps the most significant is *YaYa Ho* from 1984. Inspired by what he saw in a street bar in Haiti where electricity was being siphoned off the power grid illegally but ingeniously, *YaYa Ho* was a completely original way of lighting a room. It uses an array of dangling mirrors, shades and lamps hanging from a pair of current carrying wires.



**Ingo Maurer lights are playful, delicate and full of the kind of emotional expression that makes them much more than simple utilitarian objects.**



It is a non-system system, a kit of parts with no finite form, that requires a creative input from the user. It demands more commitment than a simple purchase. Ingo was neither a modernist nor a post-modernist. The imagery of *YaYa Ho* is tribal meets high tech, with allowances for the possibility of imperfection of handwork and the patina that goes with it.

Ingo Maurer explored the nature of artificial light against the background of a continually evolving technology which gathered speed during the course of his career. Ingo was always a pioneer user of new light sources. He worked with dichroic bulbs, and later with LEDs, using them to recreate in a contemporary way some of the qualities of candlelight.

But he remained fascinated by Edison's invention of the tungsten filament incandescent lamp. A light bulb is a genuine icon, its instantly recognisable shape is universally understood as signifying light, and as a figure of speech is used to suggest enlightenment. The *Lucellino*, one of several Ingo Maurer designs in the collection of MoMA in New York, transforms what looks like a standard bulb with the addition of a tiny pair of feathered wings. The end of tungsten filament bulbs means that the light source inside the specially made bulb is now an ambient LED.

When the tungsten bulb was abolished in the European Union, and then subsequently in the USA, *Wo Bist Du Edison*, another Ingo Maurer tribute to Thomas Edison, was a ceiling light that involved the holographic image of a light bulb projected on an acrylic shade, with a socket shaped like Edison's profile.

Ingo Maurer's work was always unpredictable, always unexpected, always impossible to typecast. He had the generosity to be continually looking for designers to collaborate with.

Ingo Maurer's products depend on a deft assembly of special components, offering a kind of updated craftsmanship. He taught his team to work with ready-made components. *Porca Miseria* is a chandelier fabricated from a cloud of smashed dinner plates and cutlery caught as if in the middle of an explosion. He made another light from a cluster of Campari bottles. At other times he used Japanese paper to create translucent shades, and printed circuit boards as the base of a digital candle.

The essence of the magic of his lights is in the way they bring to life the spaces in which they sit, rather than attempt to overwhelm them. Ingo died in 2019. He left behind a rich legacy of designs both realised that continued to be made and unrealised that can be put back into production, and a studio that continues in his creative path.

#### *Deyan Sudjic*

Deyan Sudjic is a critic, curator and writer. He is the editor of *Anima*, and a former editor of *Domus*. He was the director of the Design Museum in London from 2006 to 2020, and director of the Venice Architecture Biennale in 2002. He writes for the *Financial Times* and *the Guardian*, and is the author of several books on design, architecture and contemporary culture.

**The essence of the magic is in the way they bring to life the spaces in which they sit, rather than attempt to overwhelm them.**

**NEW CREATIONS**<sub>17</sub>

**FLOOR**<sub>39</sub>

**TABLE**<sub>61</sub>

**WALL**<sub>101</sub>

**HANGING & CEILING**<sub>141</sub>

**SYSTEMS**<sub>225</sub>

**MAMO NOUCHIES**<sub>239</sub>

# NEW

Nalum  
Shhh!  
Jasna Kuchnia  
Bruce Springsteel  
Strange Little Thing

# CREA TIONS



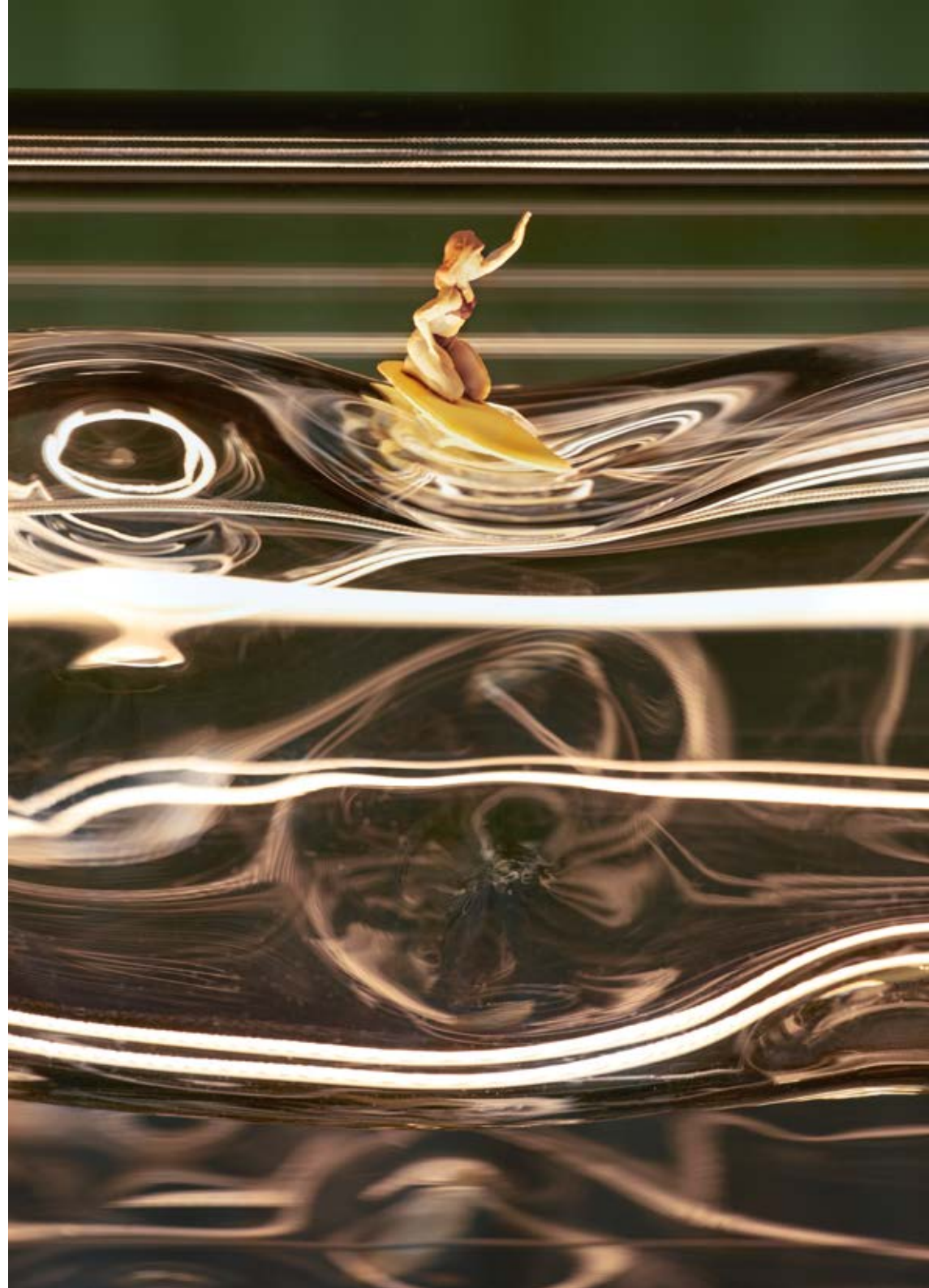

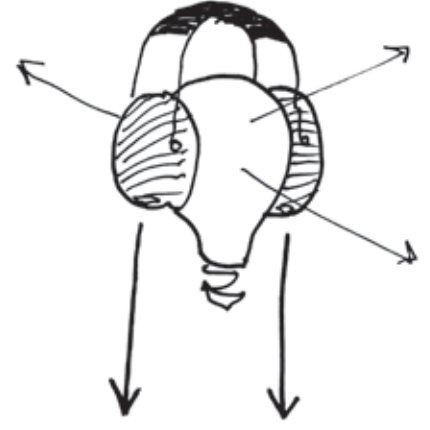



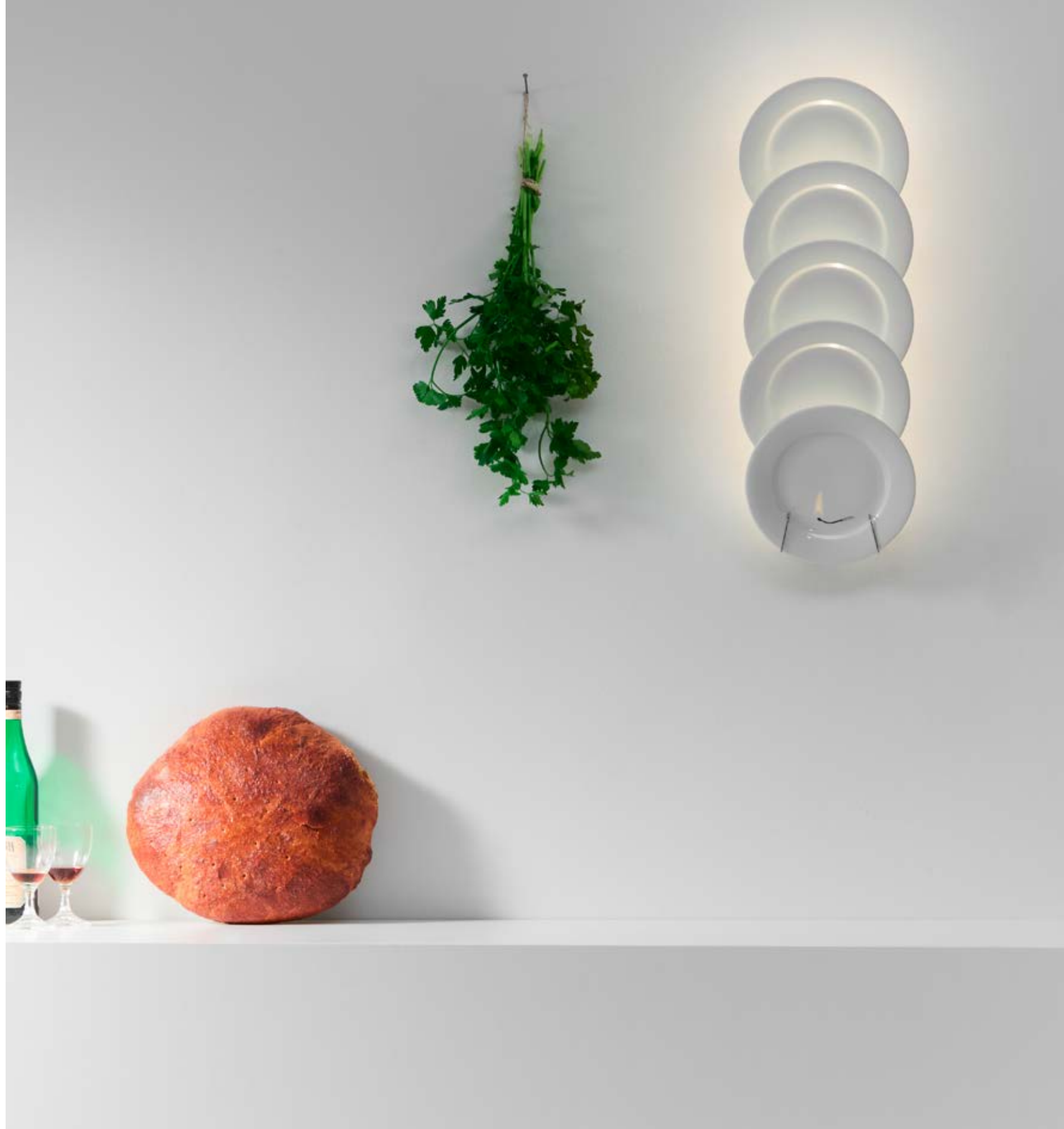
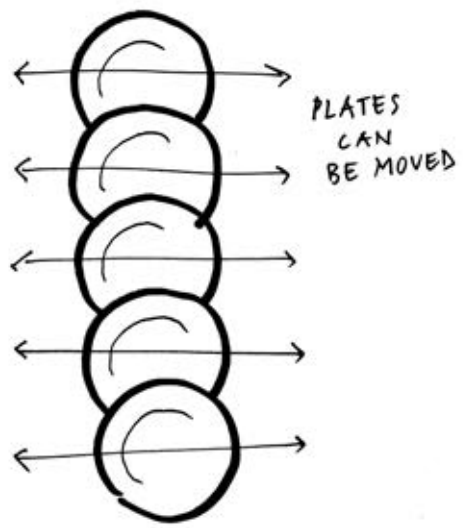









Strange Little Thing <sup>2025</sup>



# FLO

# OR

24 Karat Blau Floor  
Ilios  
Max. Floor  
MOODMOON framed  
Ms. Bowjangles  
nuunu  
Ringelpiez Floor



24 Karat Blau Floor 2009 / 2017

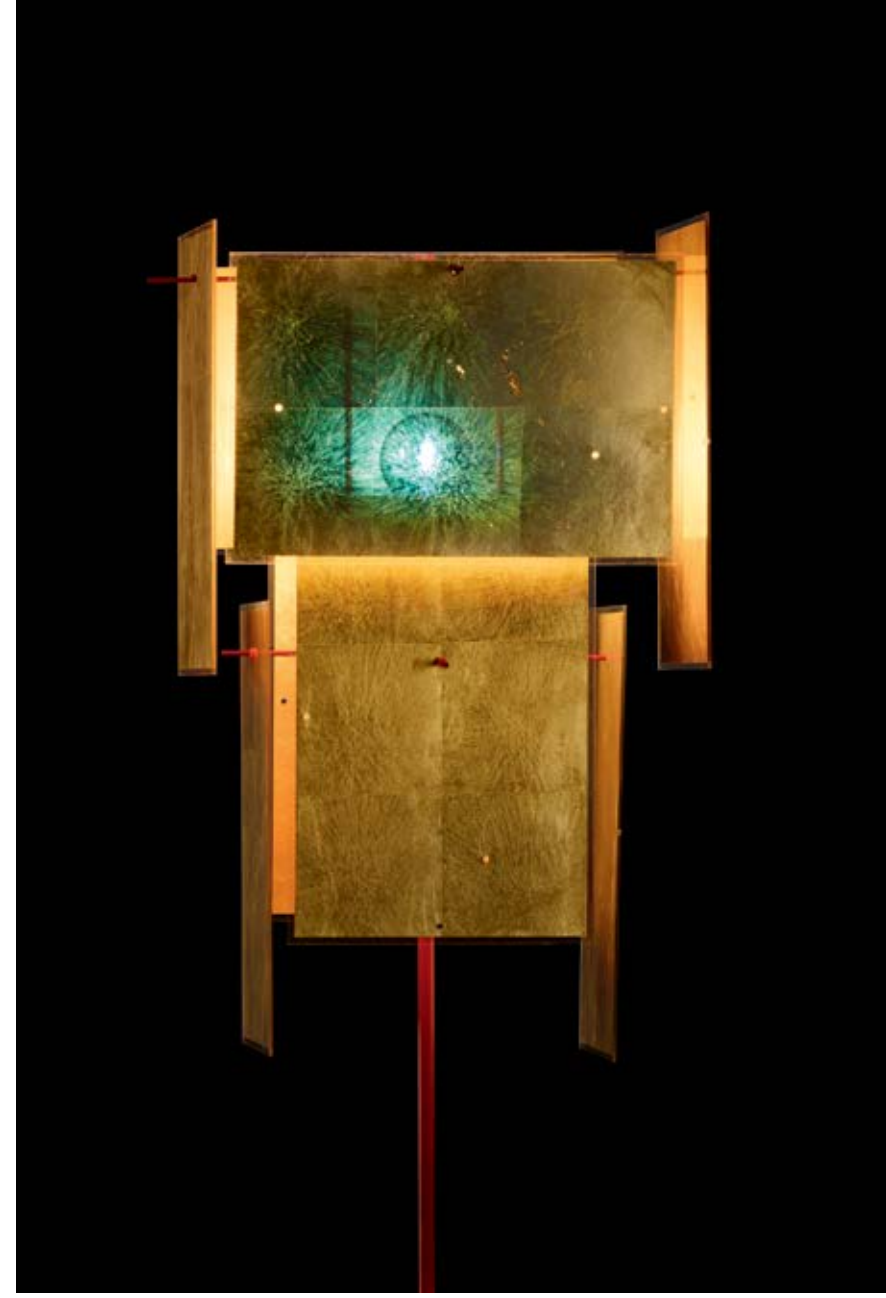

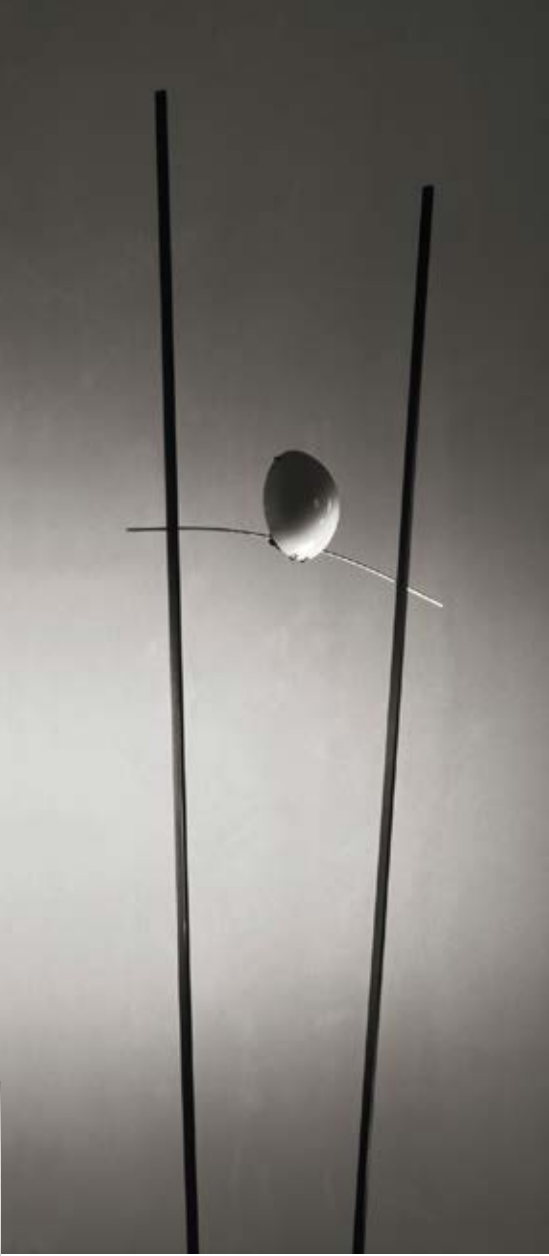

Ilios 1983

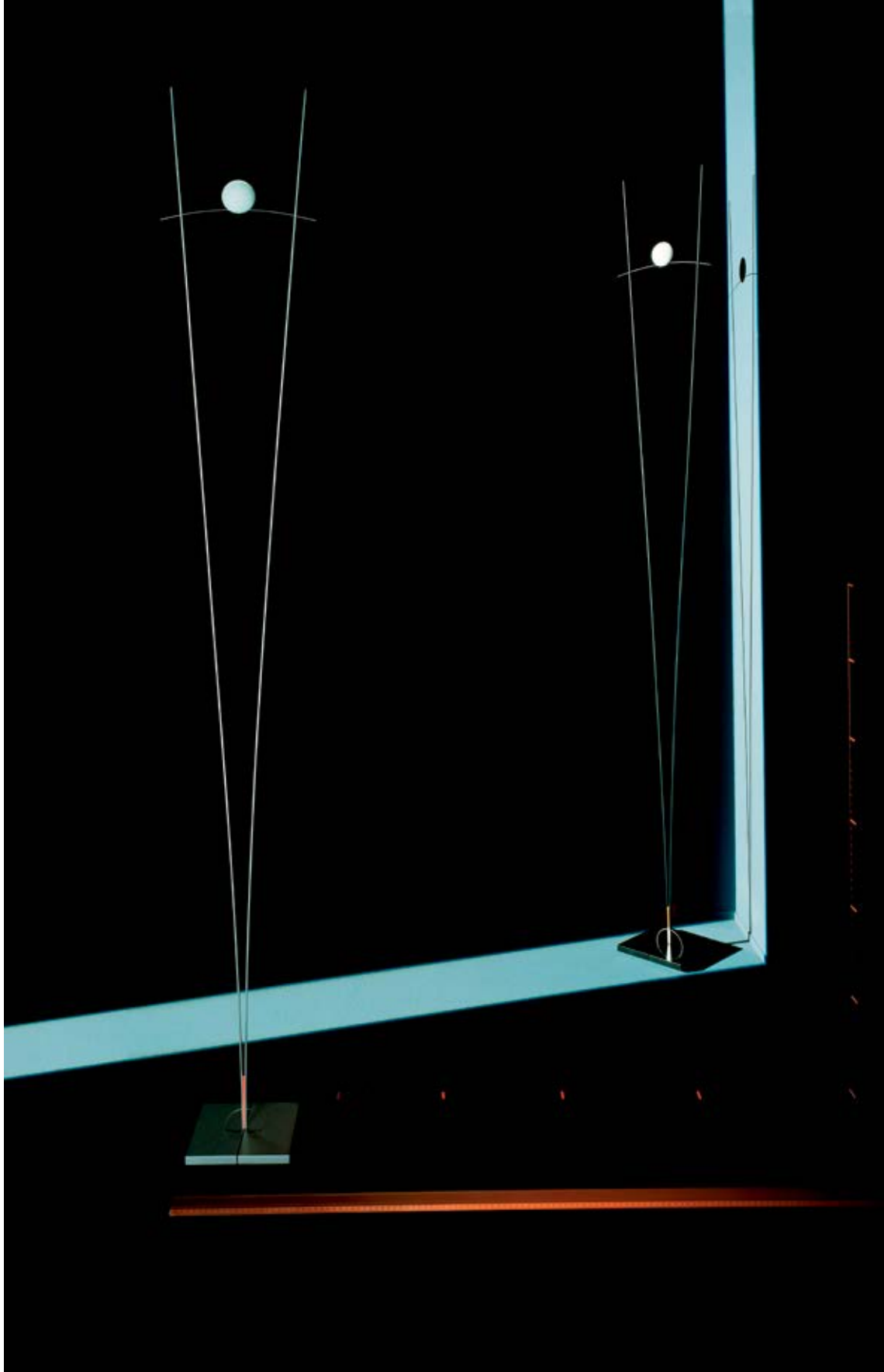

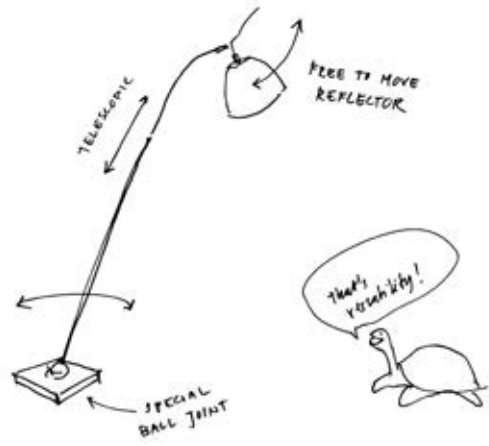

Max. Floor 2015



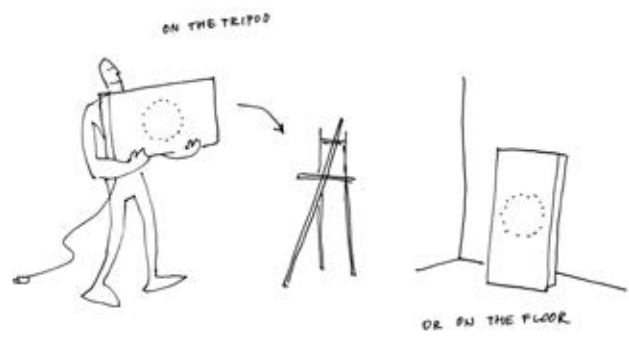



Ms. Bowjangles 2023





Ms. Bowjangles 2023





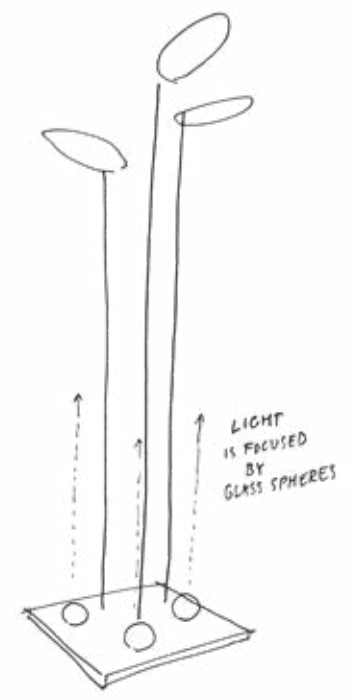

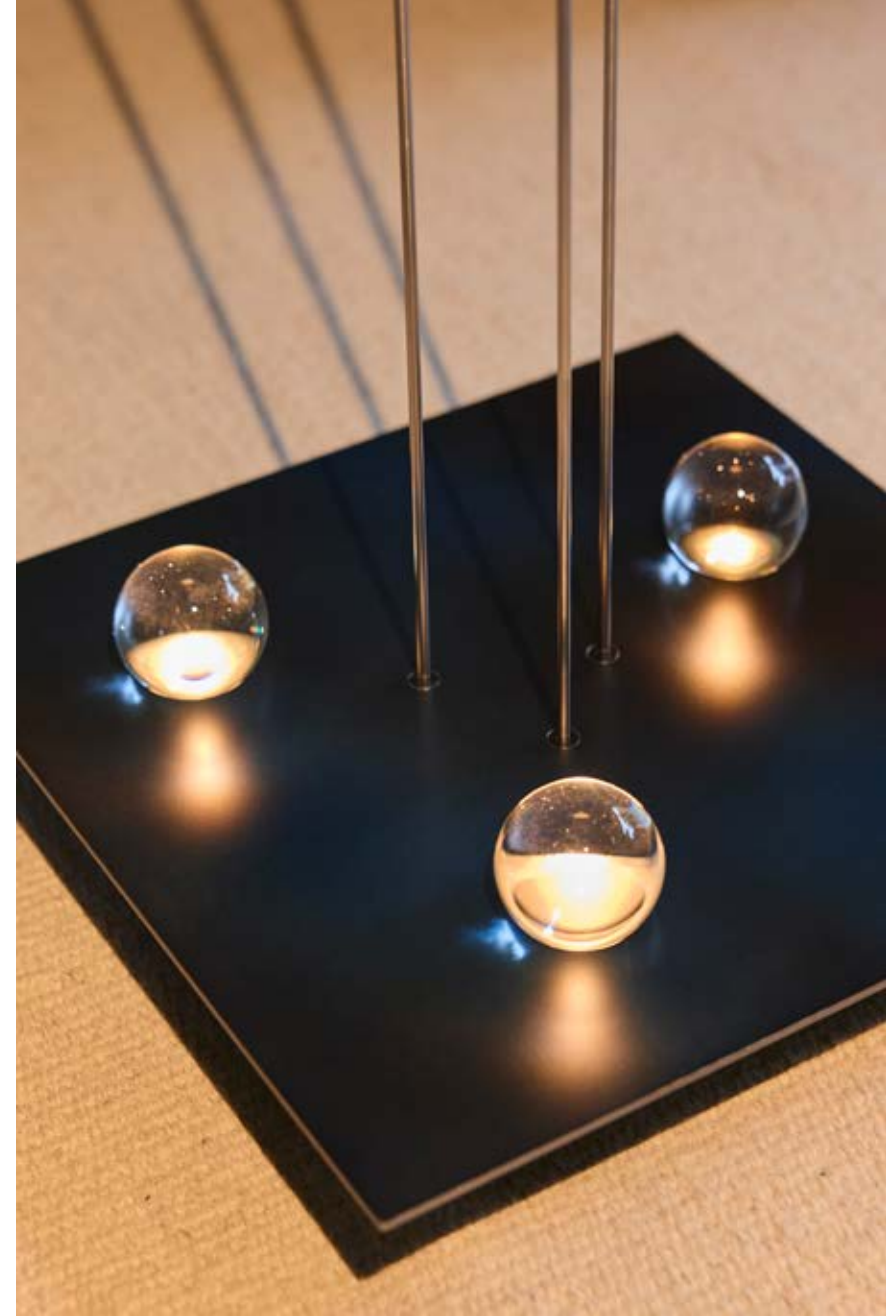



Ringelpiez Floor 2016

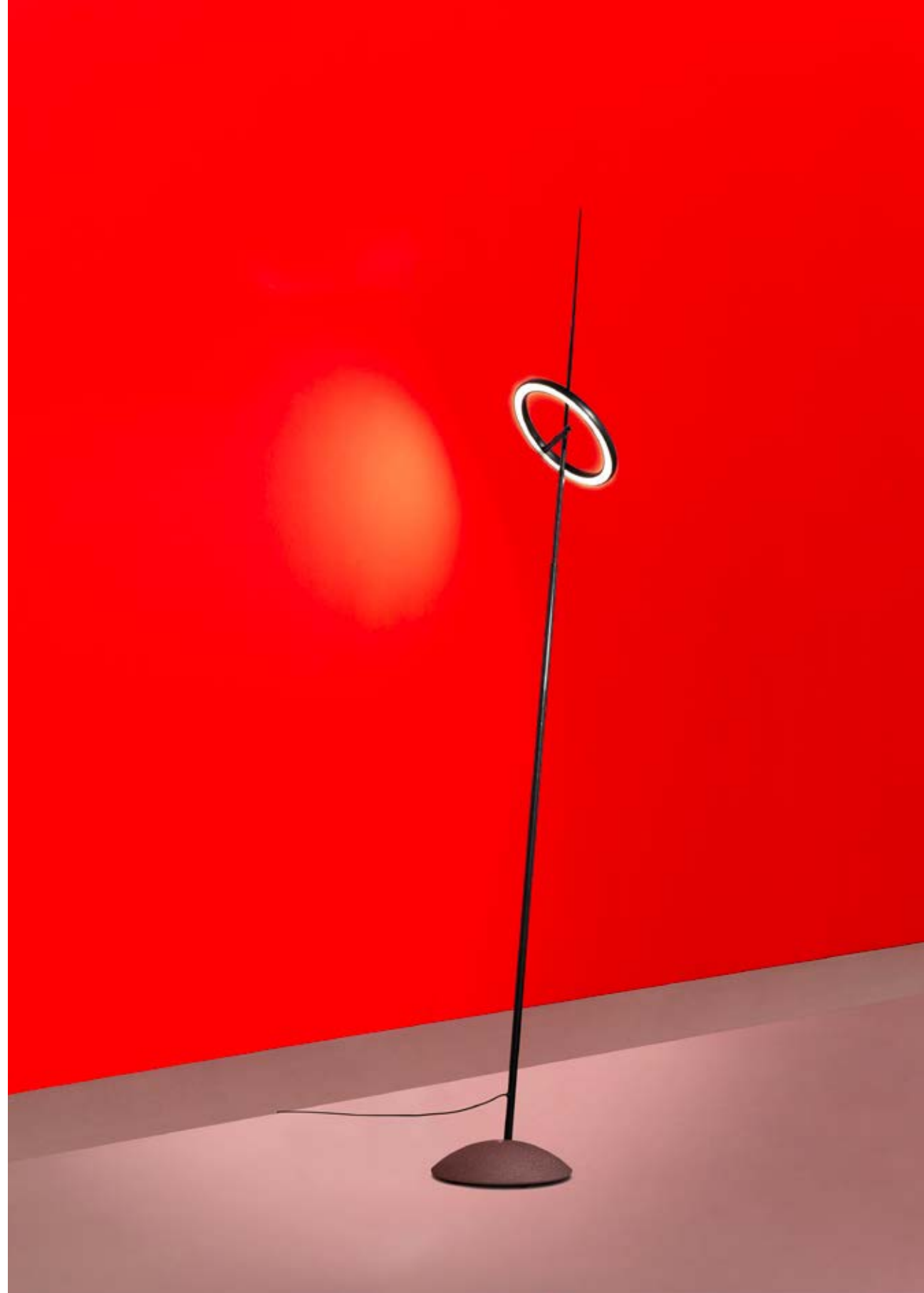

# TA

24 Karat Blau T  
BIBIBIBI  
Bulb  
Bulb Brass  
b.bulb  
Birdies Busch  
Campari Bar  
I Ricchi Poveri Bzzz  
I Ricchi Poveri Monument for a Bulb  
I Ricchi Poveri Toto  
Kamishibai  
Koyoo  
Lampampe  
Lucellino Tisch  
Lucellino Touch  
Max. Kugler  
My New Flame  
Mozzkito  
One From The Heart  
Tubular Balance

# BLE

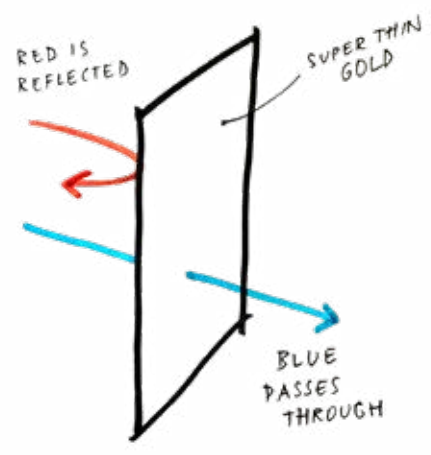

24 Karat Blau T 2005





BIBIBIBI 1982

Bulb 1966



Bulb Brass 2021









Campari Bar 2013



I Ricchi Poveri Bzzzz 2014 / 2022



I Ricchi Poveri Monument for a Bulb 2014 / 2022

I Ricchi Poveri Toto 2014 / 2022











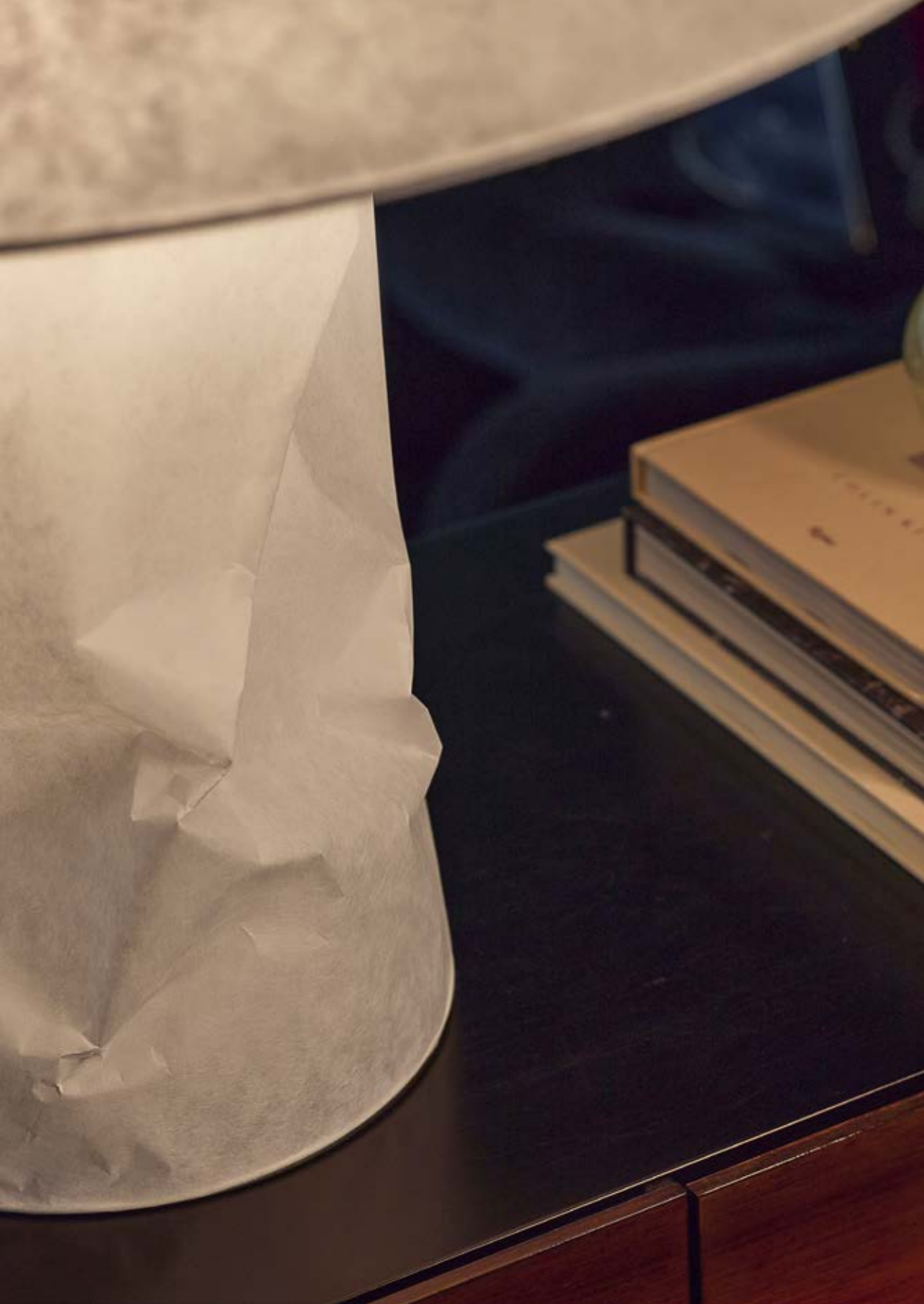







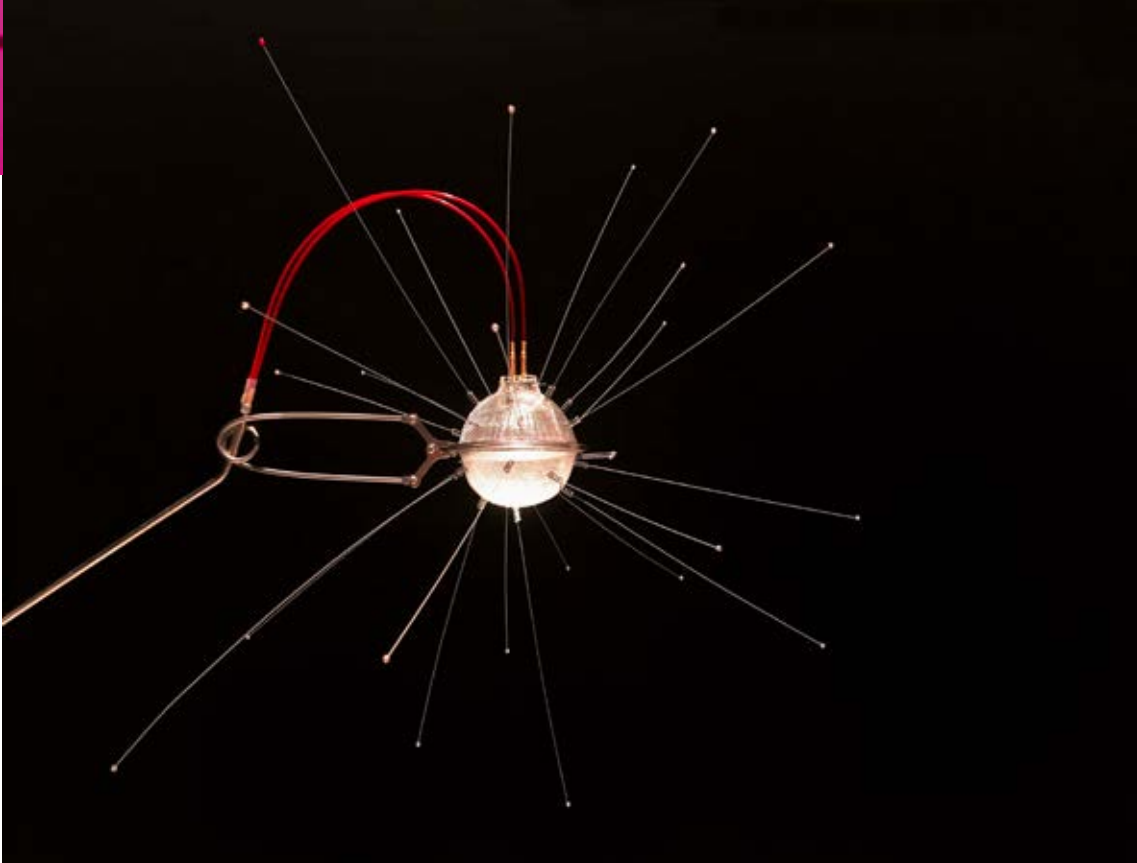
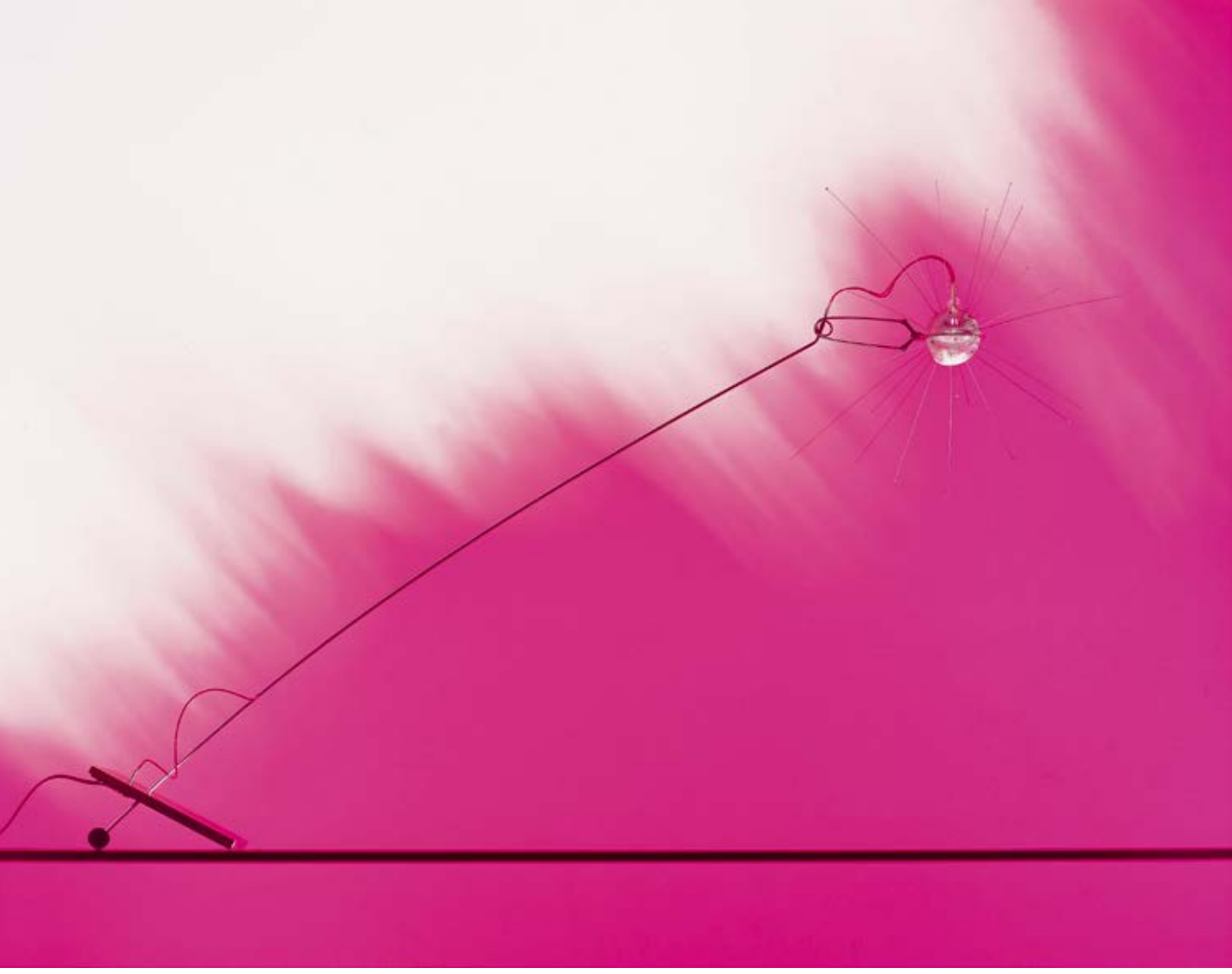



One From The Heart <sup>1989</sup>



# WA

18 × 18

24 Karat Blau Flat

24 Karat Blau W

Canned Light

Delight

Eclipse Ellipse

Holonzki

Oskar

Light au Lait

Lucellino Wall

Lucellino Doppio

Luzy On The Wall

Max. Mover

Measure Light

MOODMOON / MOODMOON White

Ms. Bowjangles wall / Ms. Bowjangles Tall wall

OOP'S / OOP'S 2

Use Me W.

# LL



18 x 18<sup>2015</sup>

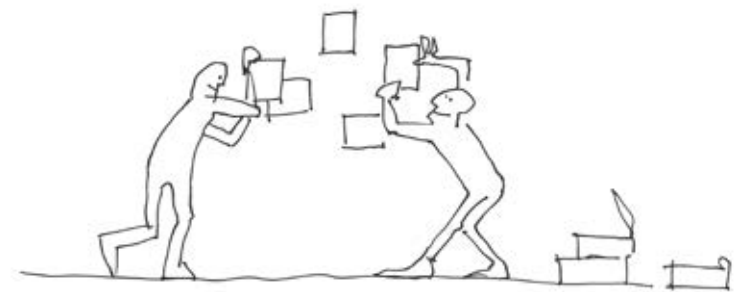
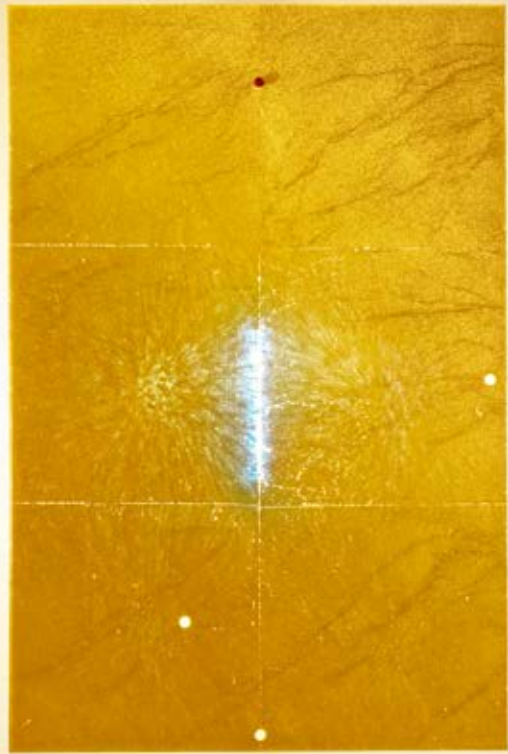



24 Karat Blau W 2017

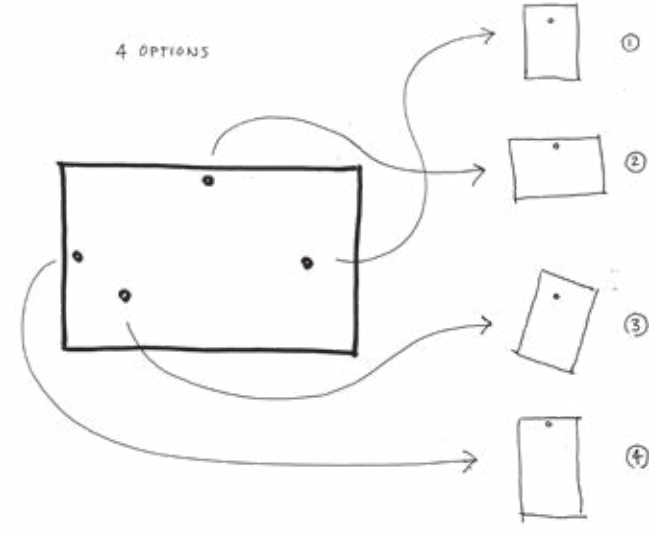





Delight <sup>1980</sup>

**111**









Light au Lait 2004



Lucellino Wall<sup>1992</sup> / Lucellino Doppio<sup>2018</sup>



Luzy On The Wall <sup>2018</sup>



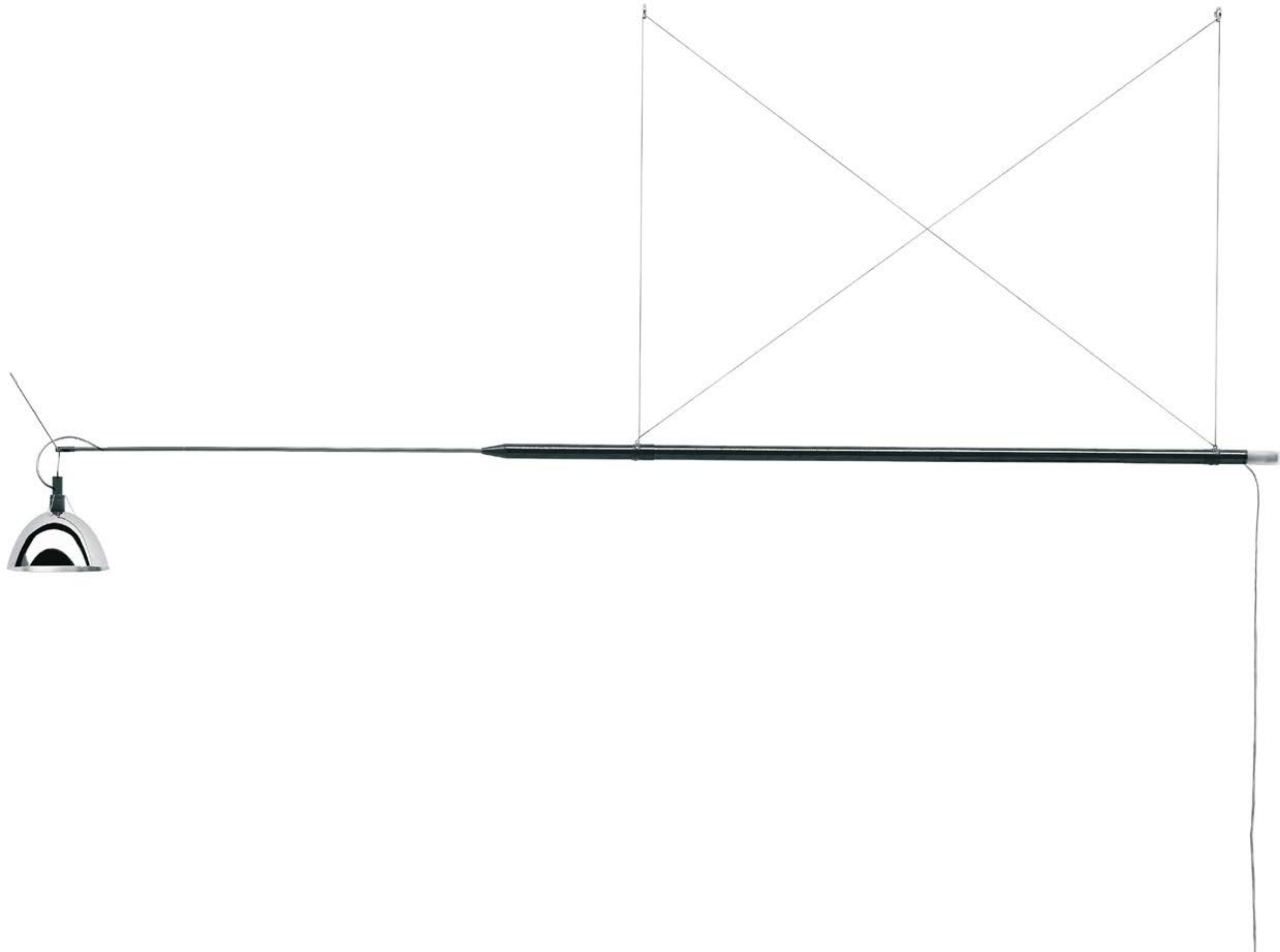

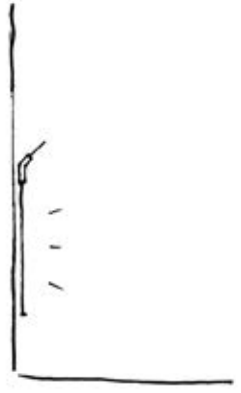

LOW LIGHT

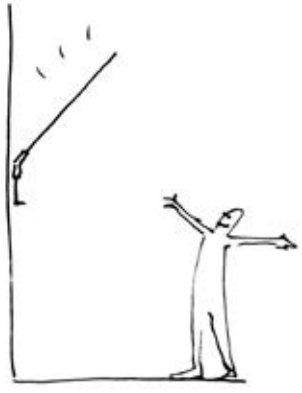

UP LIGHT

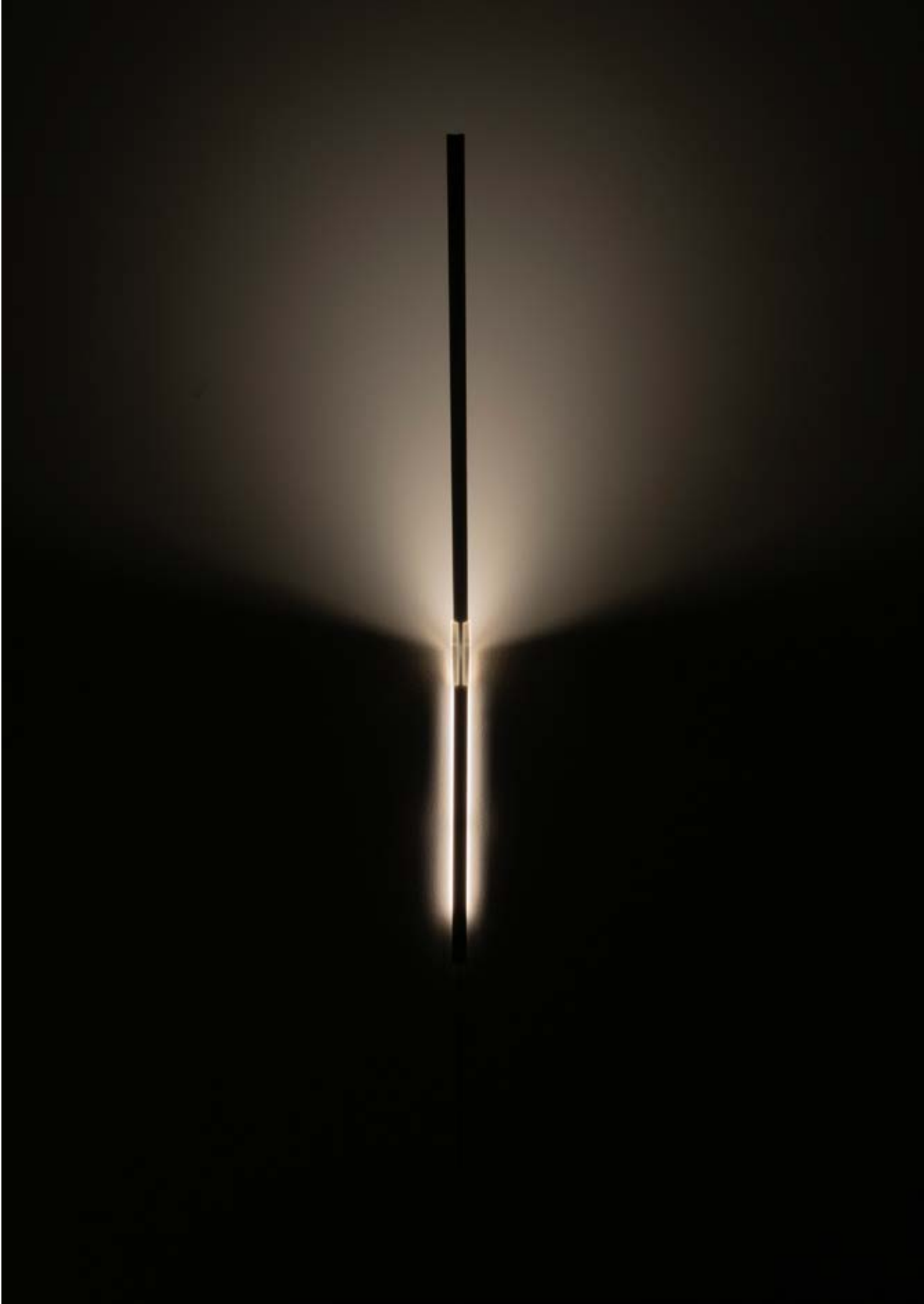



MOODMOON / MOODMOON White 2021

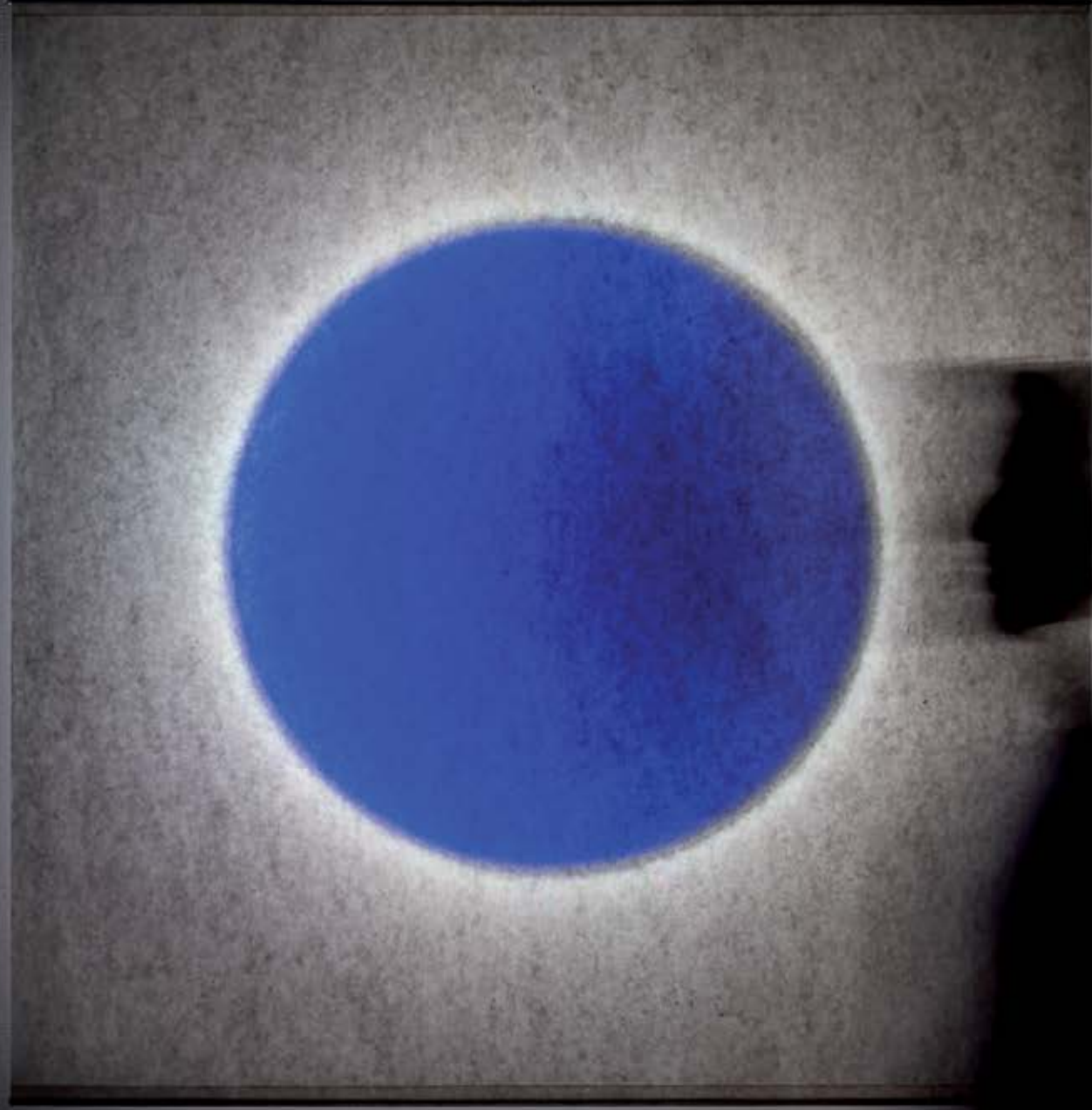

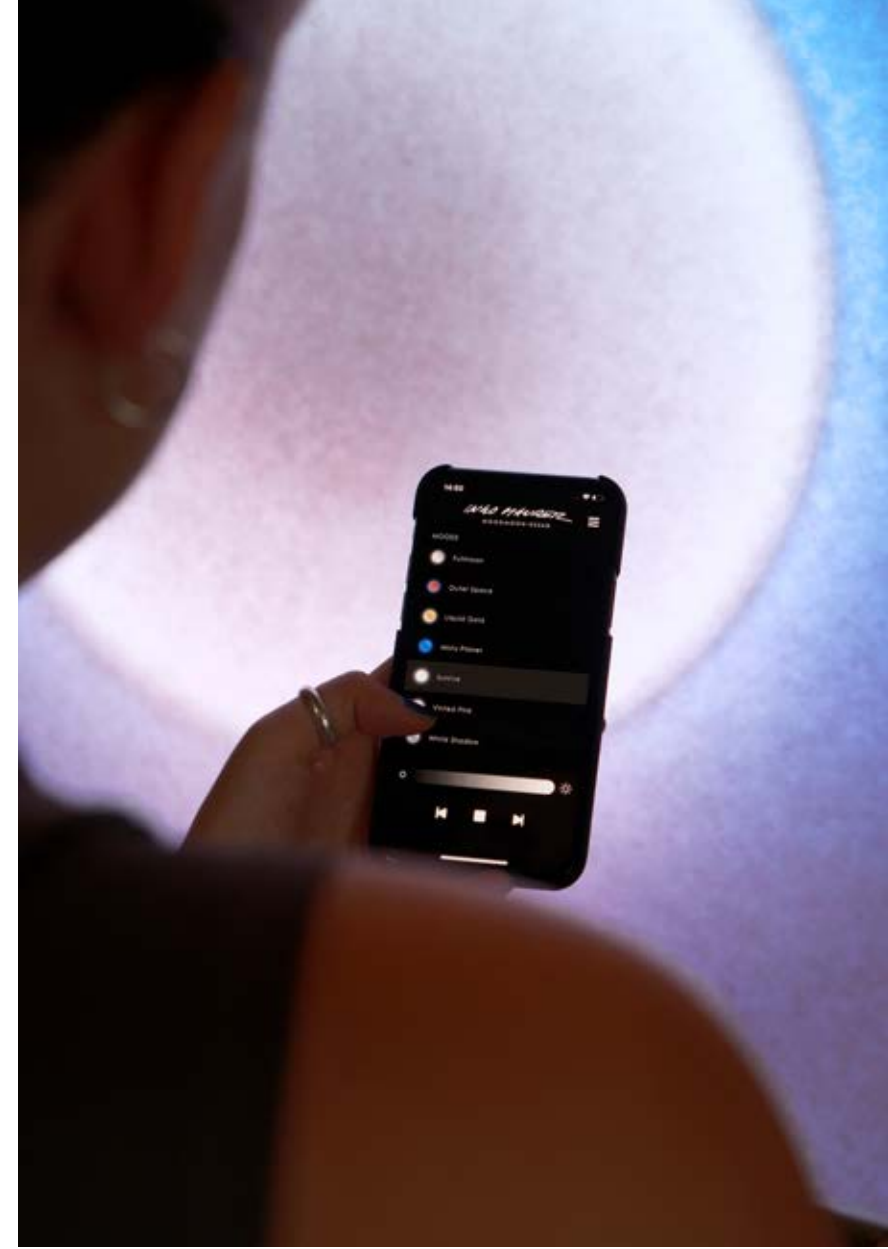



134

Ms. Bowjangles wall / Ms. Bowjangles Tall wall <sup>2023</sup>







Use Me W. 2010



18 × 18  
24 Karat Blau / 24 Karat Blau M  
1000 Karat Blau  
Birdie  
Birdie's Nest  
Birds Birds Birds  
Blue Luzy  
Campari Light  
Canned Light  
Floatation  
Fly Candle Fly!  
Flying Flames  
Hot Achille  
Johnny B. Bald / Johnny B. Butterfly  
Johnny B. Good  
Knitterling  
Lacrime del Pescatore  
La Festa delle Farfalle  
Lil Luxury 2 / Lil Luxury  
Lucellino Doppio

# HANG ING &

Luzy Take Five  
Maru  
Max. Mover  
One New Flame  
pic-a-stic  
Reality  
Signature / Signature Set  
Schlitz Up  
Spock  
Tubular  
Use Me C.  
WillyDilly  
Zettel'Z 5  
Zettel'Z 5 - Laughing Buddha  
Zettel'Z 6  
Zuuk

# CEI LING





24 Karat Blau / 24 Karat Blau M 2005

1000 Karat Blau 2009 / 2016



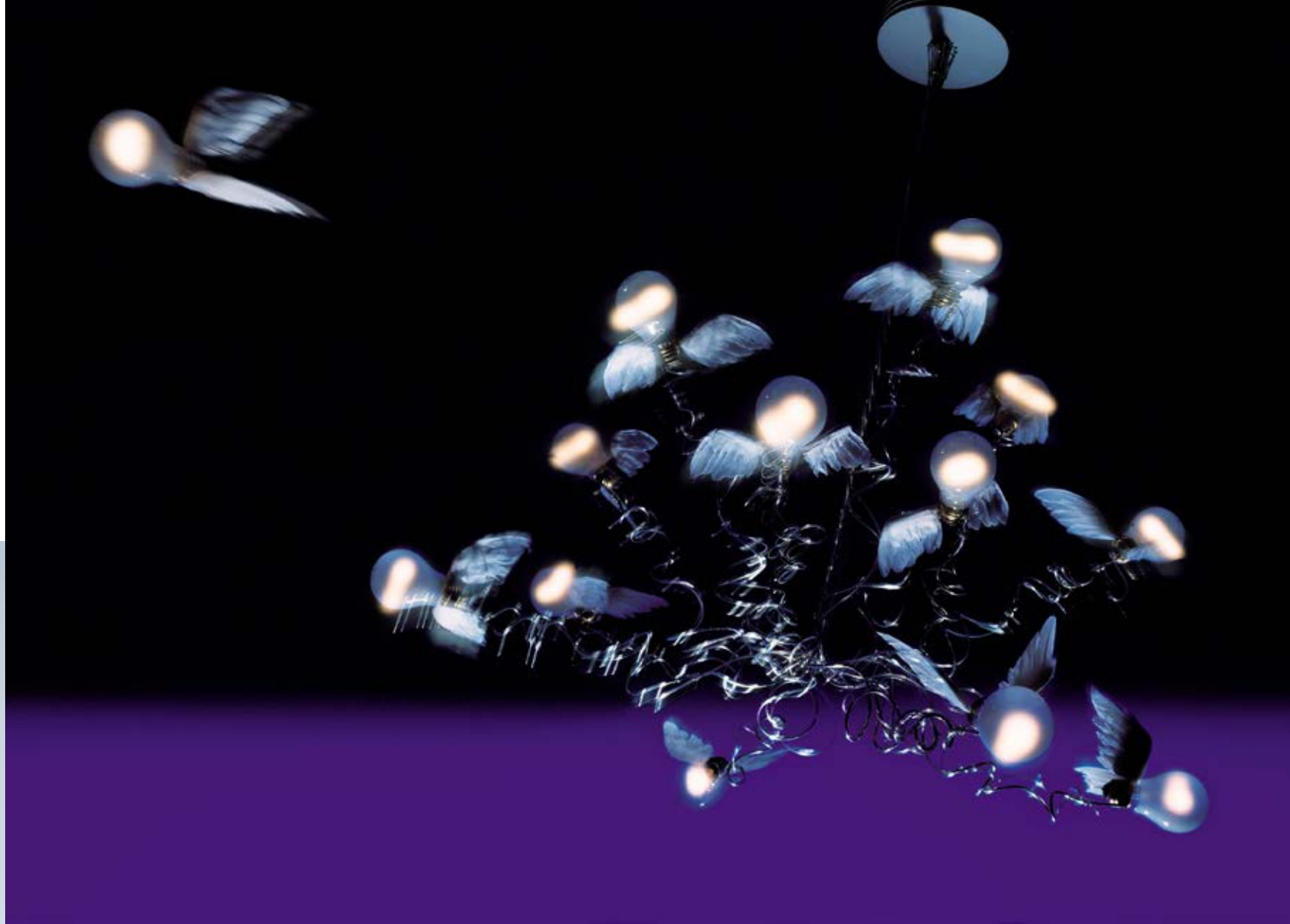

Birdie 2002 / 2017







Blue Luzy 2018







Canned Light 2003





Floatation 1980



Fly Candle Fly 1996





Flying Flames 2013

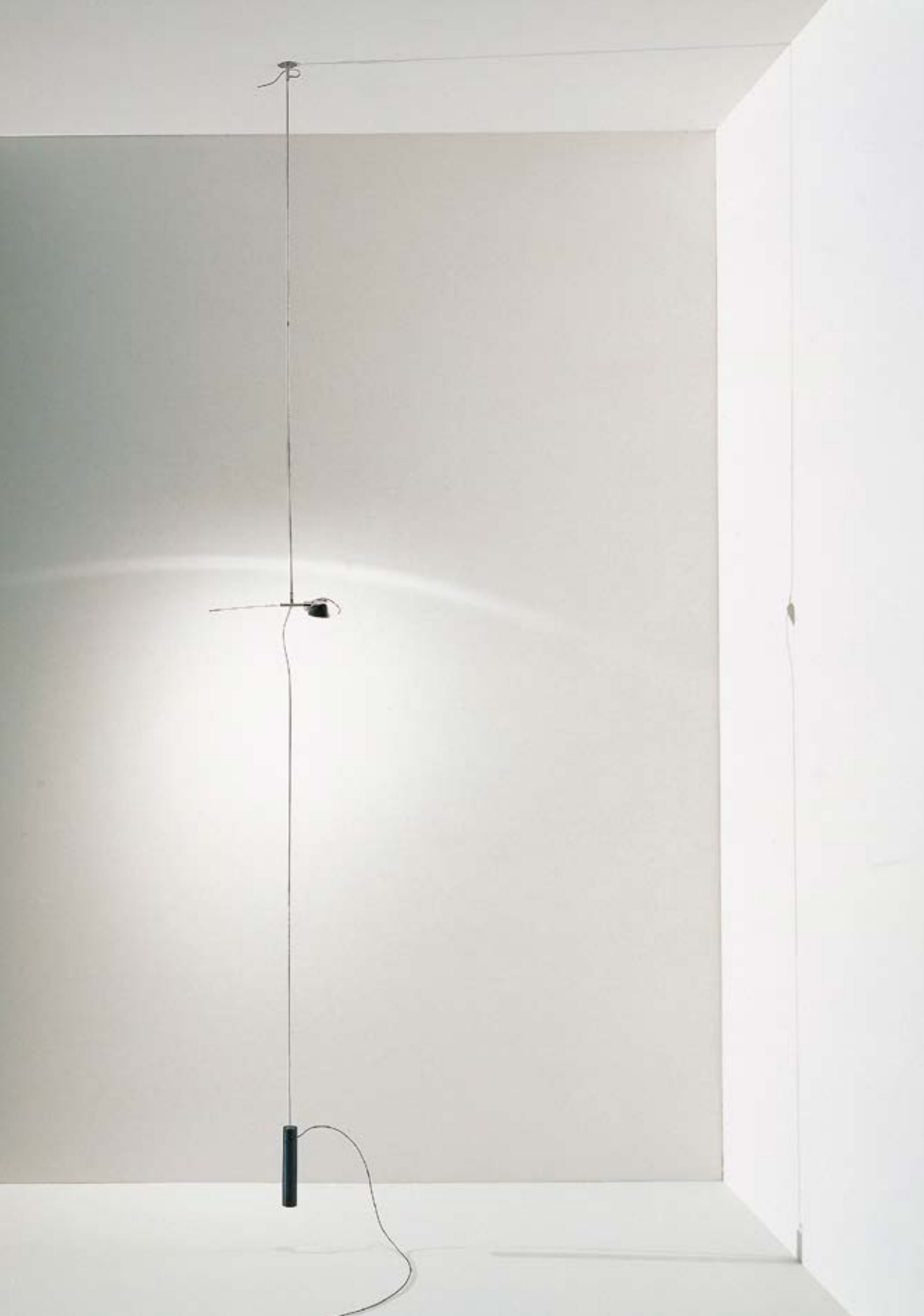

**Hot Achille** 1994 / 2019



172



Johnny B. Bald 2020 / Johnny B. Butterfly 2011

173

Johnny B. Good<sup>2002</sup>





Knitterling 1978

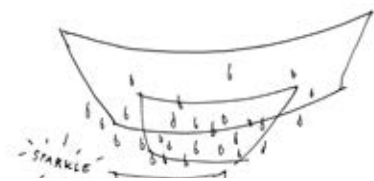

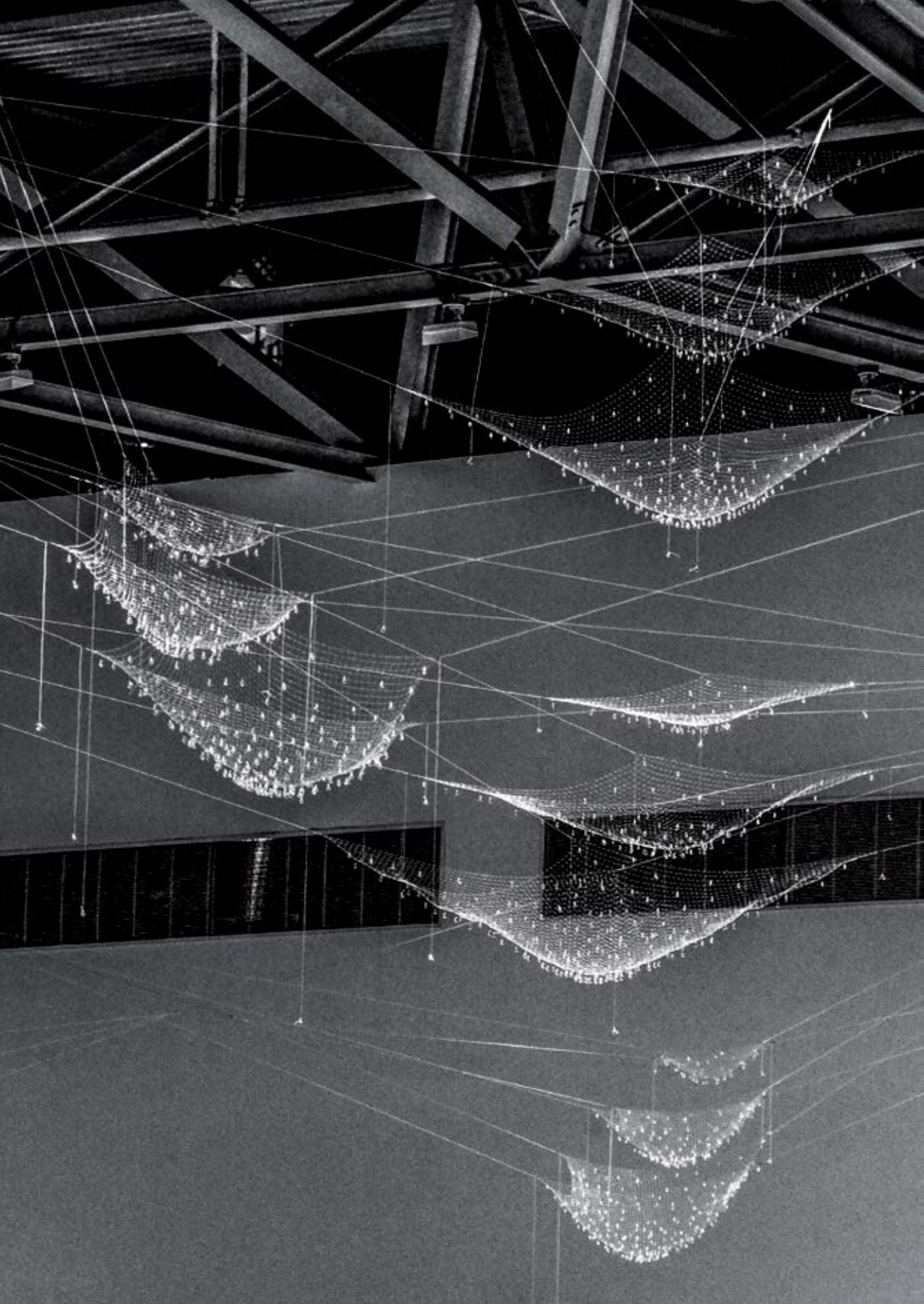



La Festa delle Farfalle 2019







Luzy Take Five (arrangement) 2018







One New Flame 2013





196

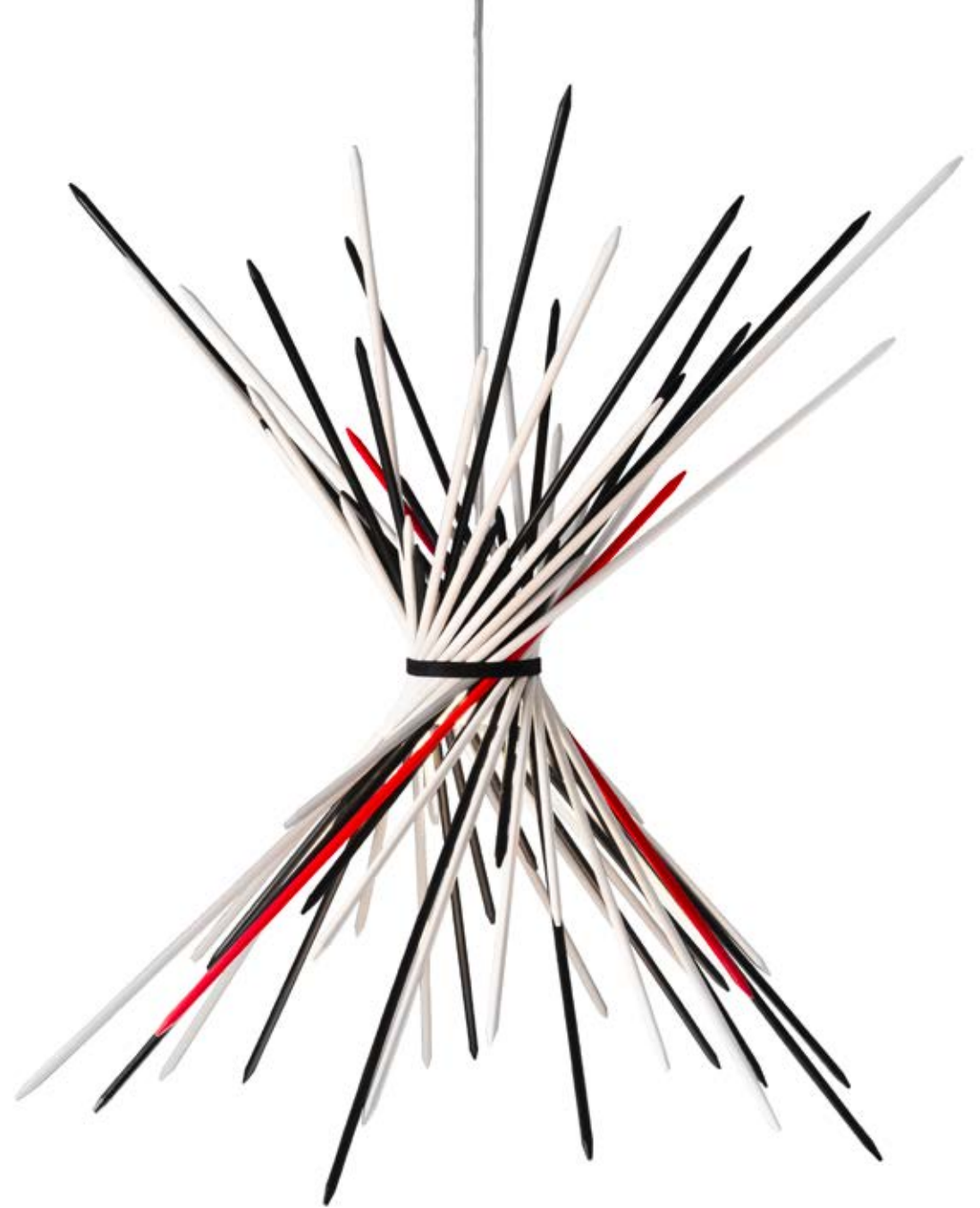

pic-a-stic 2022

197





Reality 2023





204





Schlitz Up 2002





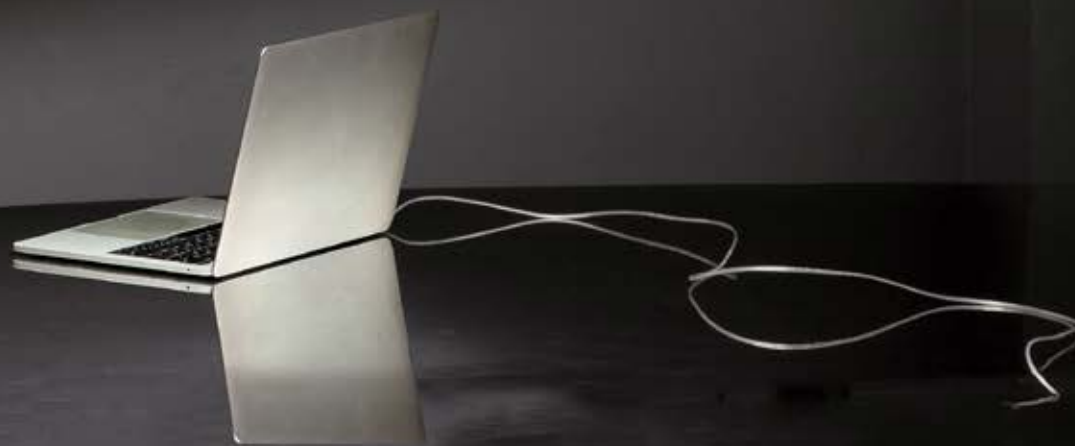
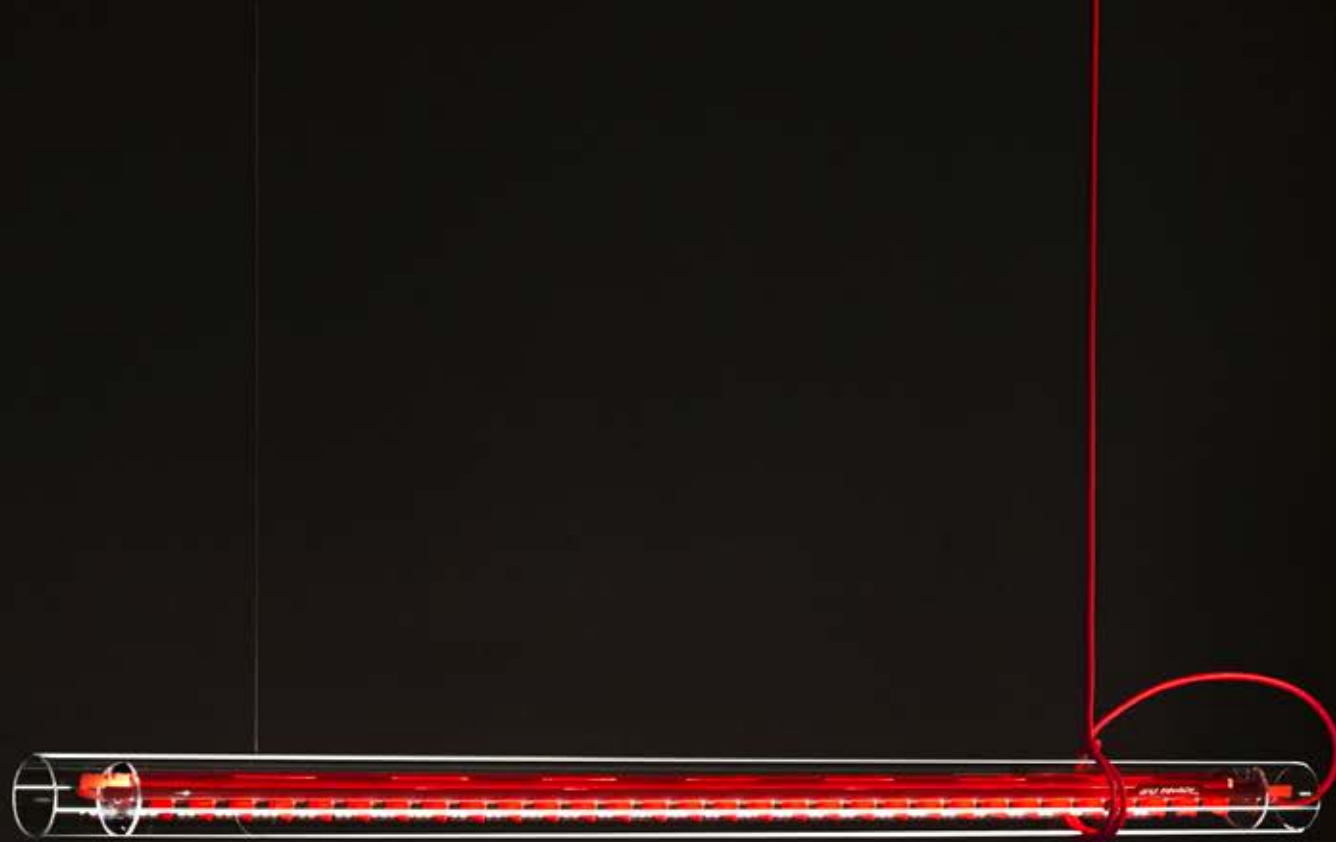

212



Use Me C. 2010

213





WillyDilly 1983



Zettel'Z 5 1997









Zuuk 1994

# SYS

Bakarù  
YaYaHo  
YaYaHo Element 1  
YaYaHo Element 2  
YaYaHo Element 3  
YaYaHo Element 4/5  
YaYaHo Element 6  
YaYaHo Element 14  
YaYaHo Element 16  
YaYaHo Element 77

# TEMS

Bakarú 1986







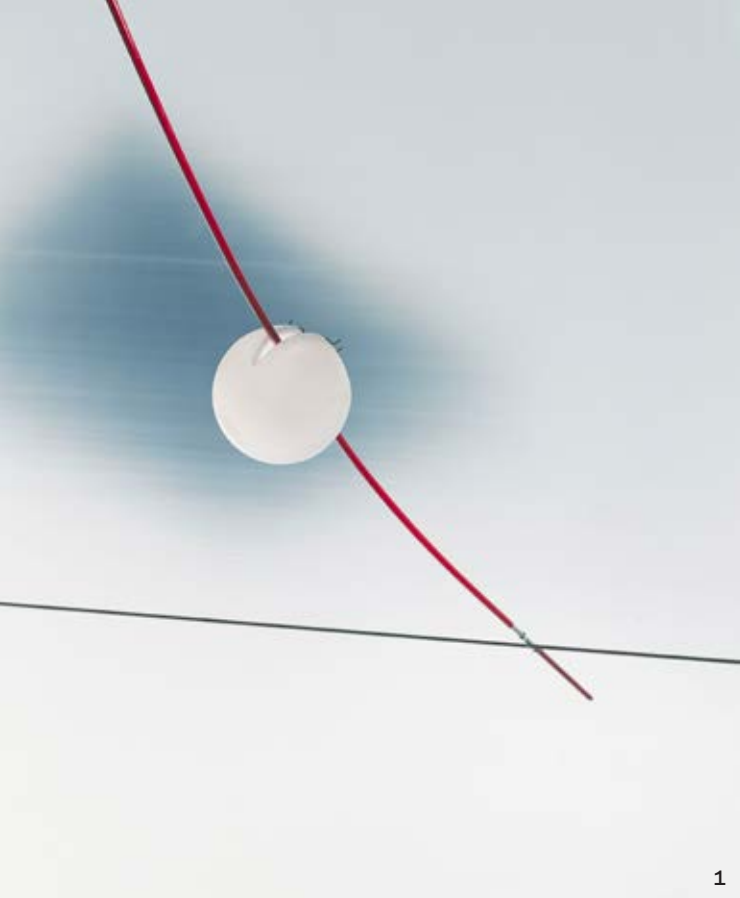



4 / 5

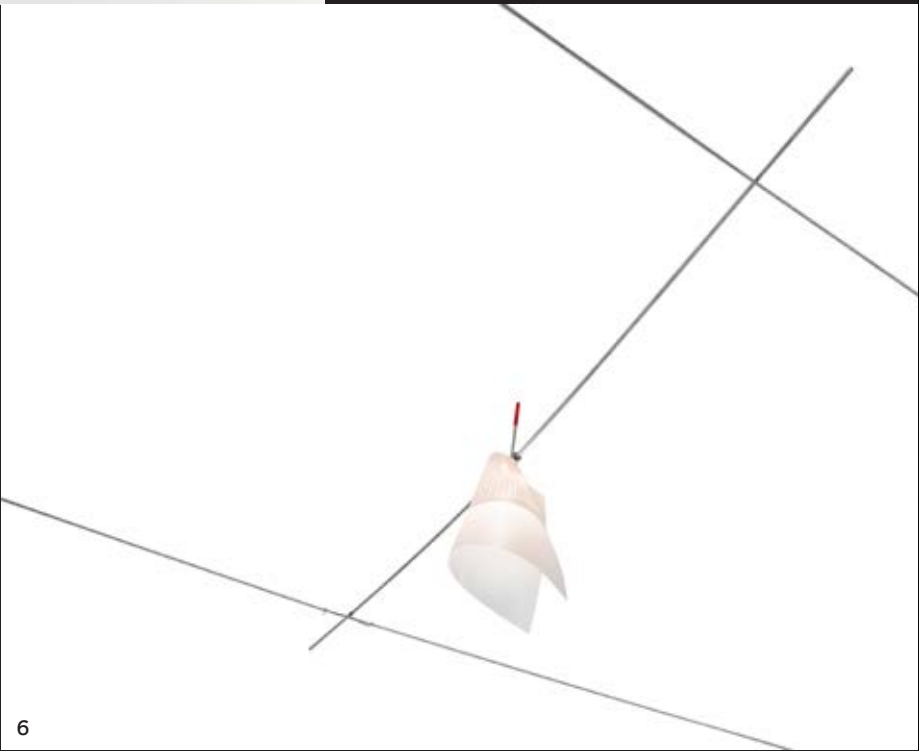

6





**MA**

**MO**

Babadul  
Kokoro  
Poul Poul  
Samurai  
Walking in the Rain  
Wo-Tum-Bu 1  
Wo-Tum-Bu 2  
Yoruba Rose Table  
Yoruba Rose Floor

**NO**

**U**

**CHIES**





Babadul 2017





Kokoro 1998

Poul Poul<sup>1998</sup>



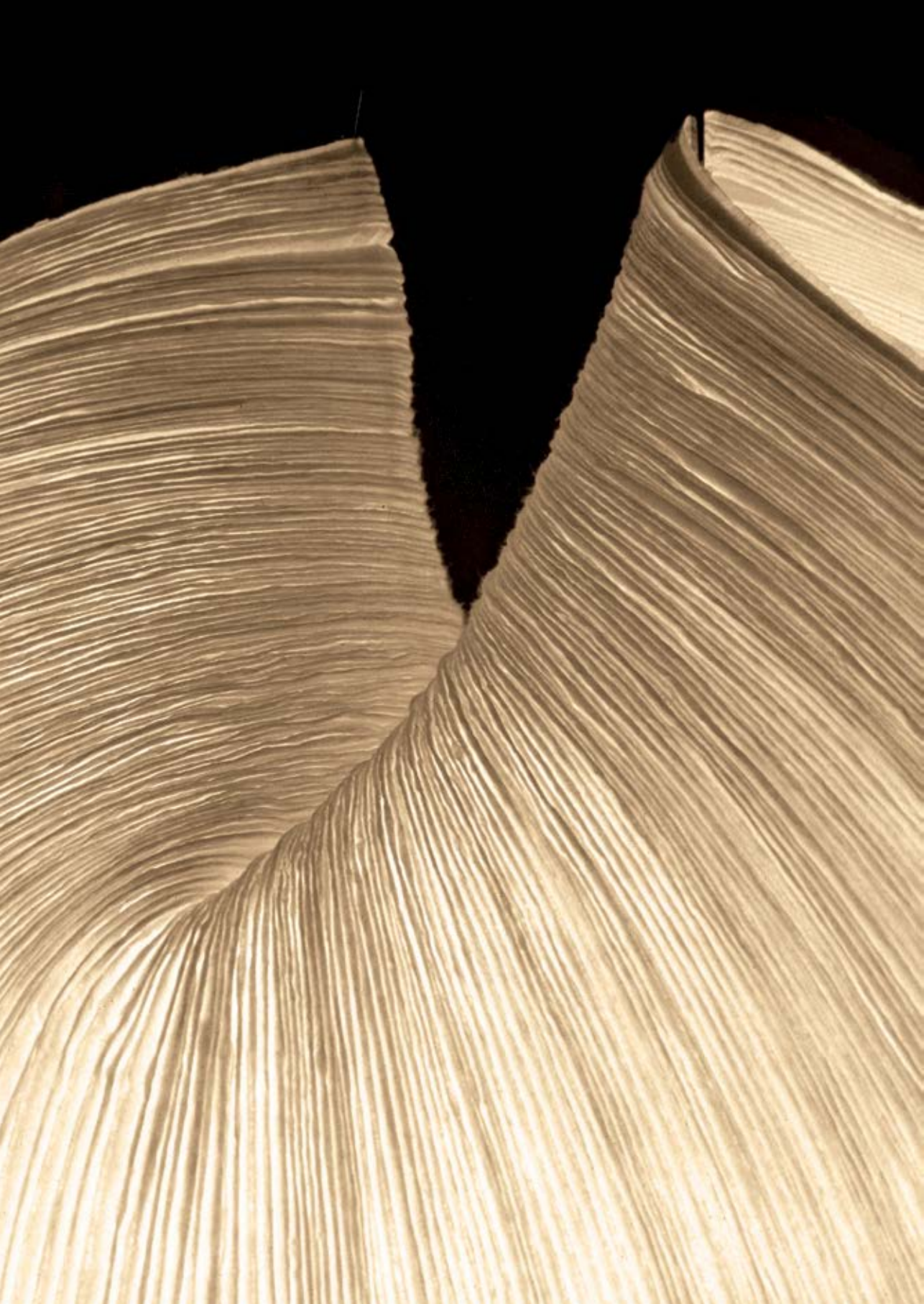











Walking in the Rain 2017





Wo-Tum-Bu 1 1999

Wo-Tum-Bu 2 1999

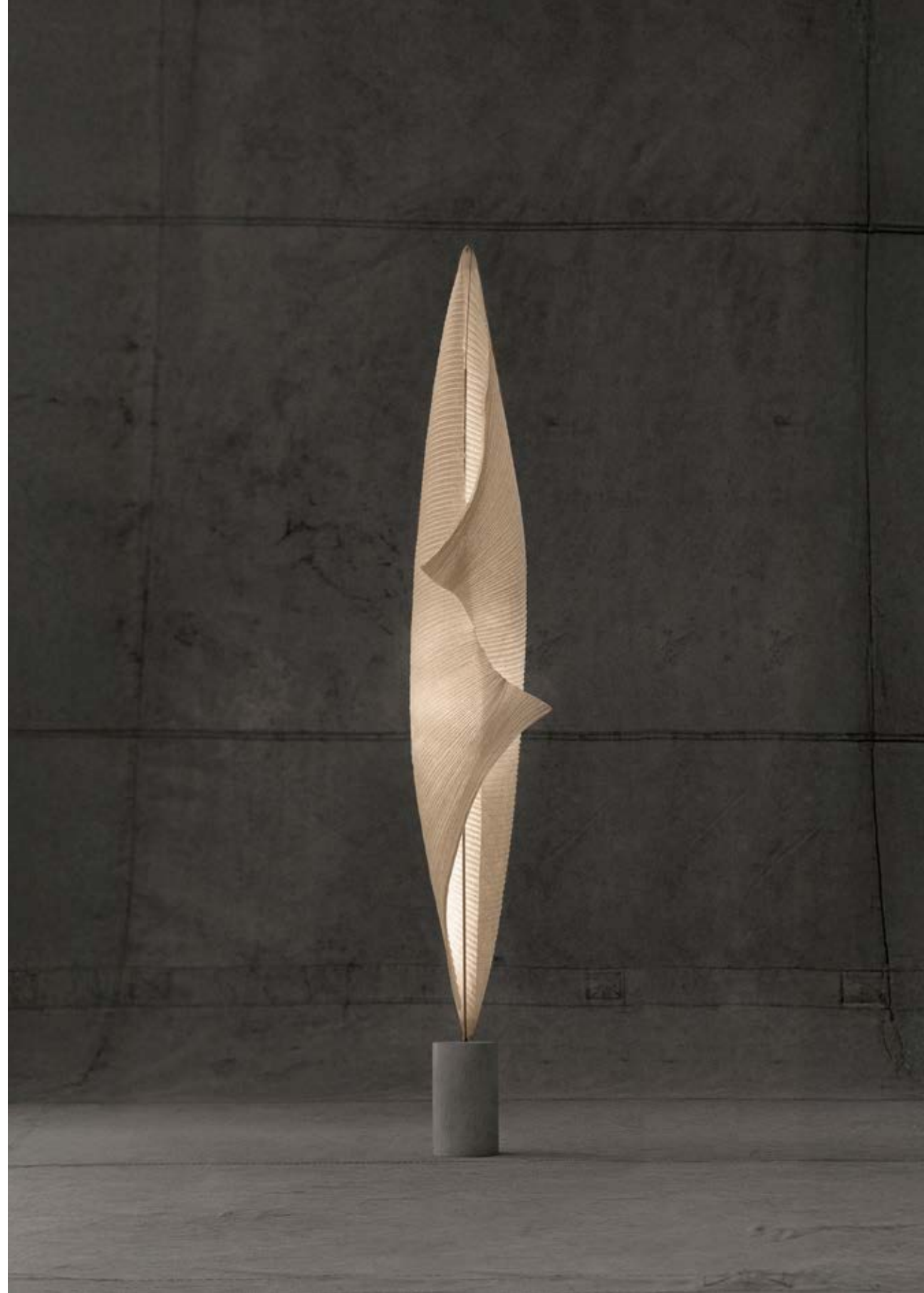



Yoruba Rose Floor 2020

Yoruba Rose Table 2017





**TECH  
NICAL**

**INFOR  
MATION  
TION**



# NEW CREATIONS

## NALUM

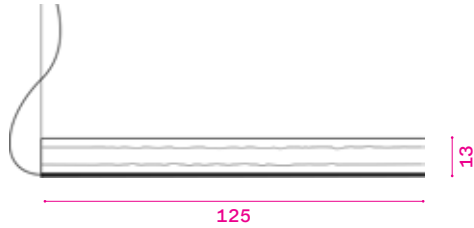

DESIGNER Sebastian Hepting  
YEAR 2025  
MATERIAL Glass, aluminum  
COLOR Transparent  
LIGHT SOURCES LED integrated



## Shhh!

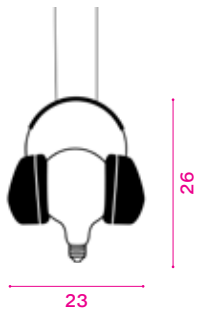

DESIGNER Ingo Maurer Team  
YEAR 2025  
MATERIAL Plastic, steel  
COLOR Headphones black, orange  
LIGHT SOURCES LED integrated



## Jasna Kuchnia

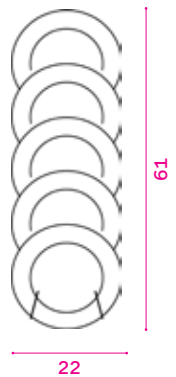

DESIGNER Ingo Maurer Team  
YEAR 2025  
MATERIAL Porcelain  
COLOR White and grey  
LIGHT SOURCES LED integrated



## Bruce Springsteel



DESIGNER Ingo Maurer Team  
YEAR 2025  
MATERIAL Glass, aluminium, steel, plastic  
COLOR Transparent and silver  
LIGHT SOURCES LED integrated



## Strange Little Thing

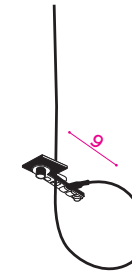

DESIGNER Axel Schmid  
YEAR 2025  
MATERIAL Aluminium, plastic  
COLOR Silver, black  
LIGHT SOURCES LED integrated



# FLOOR

## 24 Karat Blau Floor

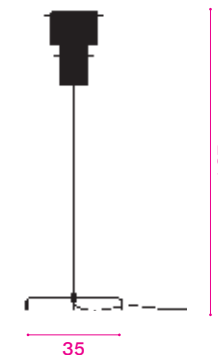

DESIGNER Axel Schmid  
YEAR 2009 / 2017  
MATERIAL Gold leaf, plastic, steel  
COLOR Red  
LIGHT SOURCES E27 Max 60W

Suitable for EEC A-G

## Ilios

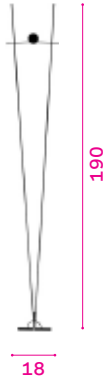

DESIGNER Ingo Maurer, Franz Ringelhan  
YEAR 1983  
MATERIAL Steel, glass  
COLOR Silver, black  
LIGHT SOURCES G4 Light bulb included



## Max. Floor

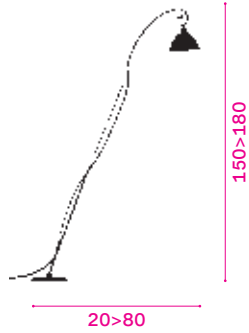

DESIGNER Ingo Maurer & Team  
YEAR 2015  
MATERIAL Steel, aluminum  
COLOR Reflector black and chrome  
LIGHT SOURCES LED integrated



## Ms. Bowjangles

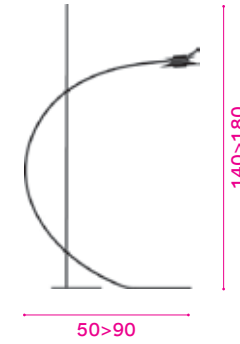

DESIGNER Anna Boch & David Engelhorn  
YEAR 2023  
MATERIAL Steel, aluminum  
COLOR Olive, orange  
LIGHT SOURCES LED integrated



## Ms. Bowjangles Tall

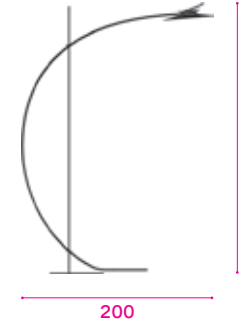

DESIGNER Anna Boch & David Engelhorn  
YEAR 2023  
MATERIAL Steel, aluminum  
COLOR Olive, orange  
LIGHT SOURCES LED integrated



## MOODMOON framed

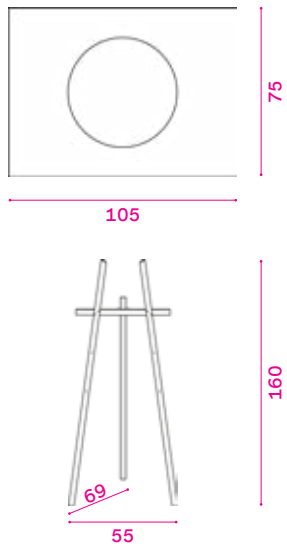

DESIGNER Sebastian Hepting  
YEAR 2023  
MATERIAL Paper, steel, wood  
COLOR White  
LIGHT SOURCES LED integrated



## nuunu



DESIGNER Flavia Thumshirn  
YEAR 2023  
MATERIAL Steel, glass  
COLOR Gold, blue-black  
LIGHT SOURCES LED integrated



## Ringelpiez Floor

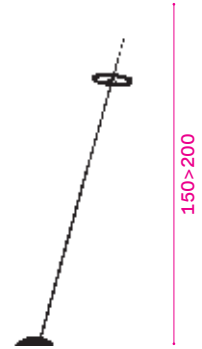

DESIGNER Ingo Maurer & Team  
YEAR 2016  
MATERIAL Steel, plastic, aluminum  
COLOR Black  
LIGHT SOURCES LED integrated



# TABLE

## 24 Karat Blau T

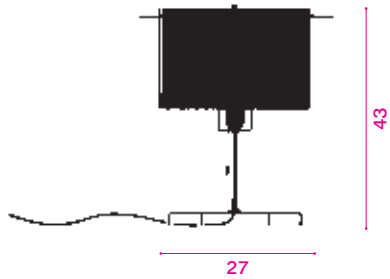

DESIGNER Axel Schmid  
YEAR 2005  
MATERIAL Gold leaf, plastic, steel  
COLOR Red  
LIGHT SOURCES E27

Suitable for EEC A-G

## BIBIBIBI

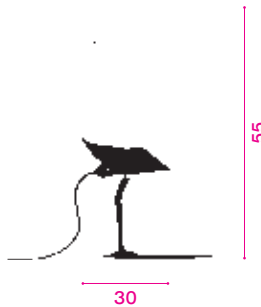

DESIGNER Ingo Maurer  
YEAR 1982  
MATERIAL Porcelain, plastic, brass  
COLOR White, red and black  
LIGHT SOURCES E27

Suitable for EEC A-G

## Bulb

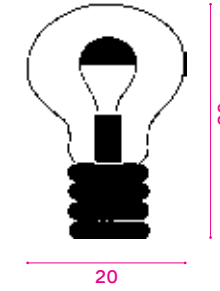

DESIGNER Ingo Maurer  
YEAR 1966  
MATERIAL Copper, glass  
COLOR Chrome  
LIGHT SOURCES E27 Light bulb included



## Bulb Brass

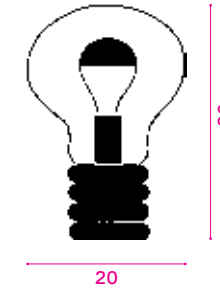

DESIGNER Ingo Maurer  
YEAR 2021  
MATERIAL Brass, glass  
COLOR Brass  
LIGHT SOURCES E27 Light bulb included



## b.bulb

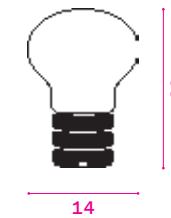

DESIGNER Ingo Maurer Team  
YEAR 2020  
MATERIAL Aluminum, glass  
COLOR Chrome  
LIGHT SOURCES LED integrated



## Birdies Busch

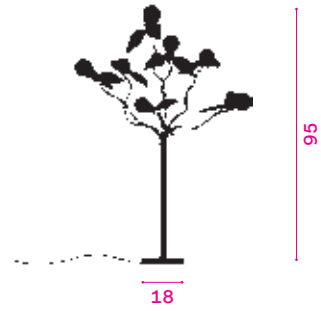

DESIGNER Ingo Maurer & Team  
YEAR 2010 / 2017  
MATERIAL Goose feathers, copper, steel  
COLOR Silver  
LIGHT SOURCES E27 Light bulbs included



## I Ricchi Poveri Monument for a Bulb

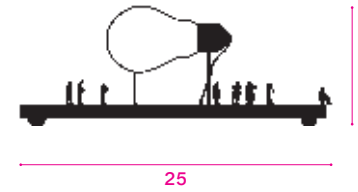

DESIGNER Ingo Maurer  
YEAR 2014 / 2022  
MATERIAL Bright steel, nickel silver  
COLOR Brass, base silver  
LIGHT SOURCES E27 Light bulb included



## Campari Bar



DESIGNER Raffaele Celentano  
YEAR 2013  
MATERIAL Melamine, plastic, brass, glass  
COLOR Black and red  
LIGHT SOURCES E27

Suitable for EEC A-G

## I Ricchi Poveri Toto



DESIGNER Ingo Maurer  
YEAR 2014 / 2022  
MATERIAL Steel, brass  
COLOR Cap black, white, red, brass, base anthracite  
LIGHT SOURCES E27 Light bulb included



## I Ricchi Poveri Bzzzz

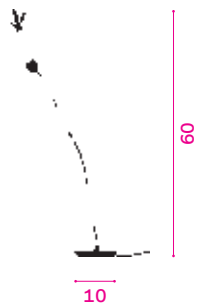

DESIGNER Ingo Maurer  
YEAR 2014 / 2022  
MATERIAL Steel, brass  
COLOR Dragonfly red, green, blue, base anthracite  
LIGHT SOURCES E27 Light bulb included



## Kamishibai

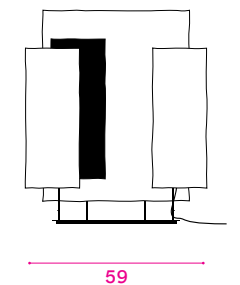

DESIGNER Ingo Maurer Team  
YEAR 2023  
MATERIAL Paper, aluminium, steel, plastic  
COLOR Silver, white, grey and black  
LIGHT SOURCES LED integrated



## Koyoo

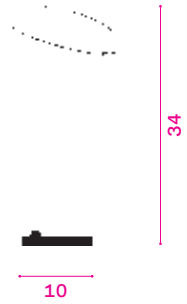

DESIGNER Axel Schmid  
YEAR 2018  
MATERIAL Aluminum, paper  
COLOR Black  
LIGHT SOURCES LED integrated



## Lucellino Touch

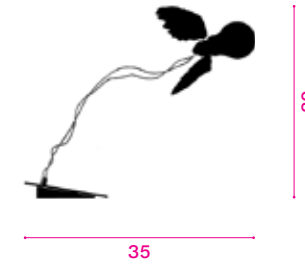

DESIGNER Ingo Maurer  
YEAR 1992 / 2023  
MATERIAL Goose feathers, steel, plastic  
COLOR Brass and white  
LIGHT SOURCES E27 Light bulb included



## Lampampe

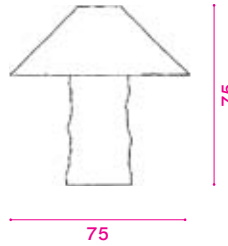

DESIGNER Ingo Maurer  
YEAR 1980  
MATERIAL Paper, steel  
COLOR White (natural)  
LIGHT SOURCES E27

Suitable for EEC A-G

## Max. Kugler

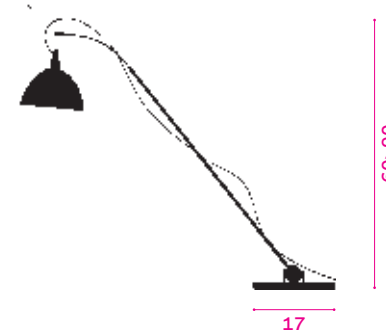

DESIGNER Ingo Maurer & Team  
YEAR 2001 / 2015  
MATERIAL Steel, aluminum  
COLOR Reflector, base chrome, reflector, base black  
LIGHT SOURCES LED integrated



## Lucellino Tisch

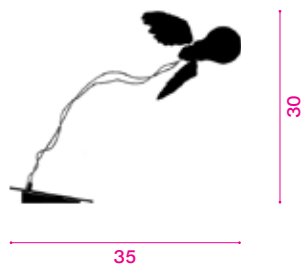

DESIGNER Ingo Maurer  
YEAR 1992 / 2022  
MATERIAL Goose feathers, steel, plastic  
COLOR Brass and white  
LIGHT SOURCES E27 Light bulb included



## My New Flame



DESIGNER Moritz Waldemeyer, Ingo Maurer & Team  
YEAR 2012  
MATERIAL Epoxy, stainless steel  
COLOR Candle element black, white, red, base black and chrome  
LIGHT SOURCES LED integrated

## Mozzkito

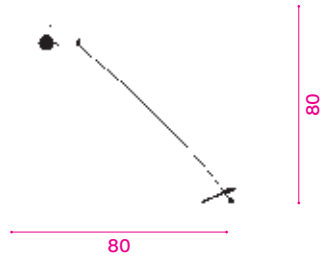

DESIGNER Ingo Maurer  
YEAR 1996  
MATERIAL Steel, plastic, silver  
COLOR Silver  
LIGHT SOURCES GU5,3

Suitable for EEC A-G

## One From The Heart

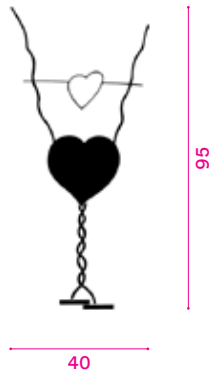

DESIGNER Ingo Maurer  
YEAR 1989  
MATERIAL Steel, copper, plastic, glass  
COLOR Red and blue, base silver  
LIGHT SOURCES LED integrated



## Tubular Balance

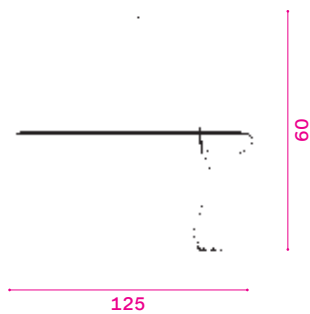

DESIGNER Sebastian Hepting  
YEAR 2021  
MATERIAL Glass, steel, aluminum  
COLOR LED unit and cable red,  
LED unit and cable white  
LIGHT SOURCES LED integrated



# WALL

18 × 18



DESIGNER Ingo Maurer & Team  
YEAR 2015  
MATERIAL Aluminum, steel  
COLOR White  
LIGHT SOURCES LED integrated



## 24 Karat Blau Flat

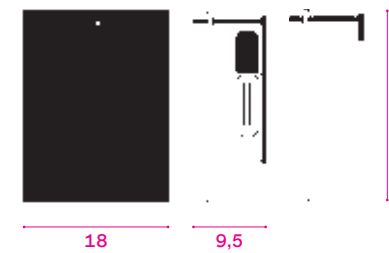

DESIGNER Axel Schmid  
YEAR 2021  
MATERIAL Gold leaf, plastic, steel  
COLOR Red  
LIGHT SOURCES E14

Suitable for EEC A-G

## 24 Karat Blau W

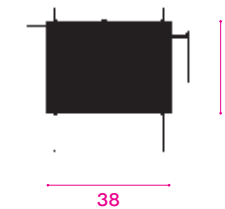

DESIGNER Axel Schmid  
YEAR 2017  
MATERIAL Gold leaf, plastic, steel  
COLOR Red  
LIGHT SOURCES E27

Suitable for EEC A-G

## Canned Light

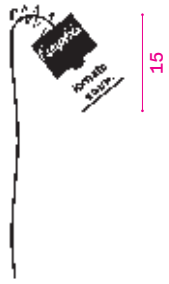

DESIGNER Christoph Matthias,  
Hagen Sczech  
YEAR 2003  
MATERIAL Tinplate, aluminum, plastic  
COLOR Red and white  
LIGHT SOURCES GU10, Light  
bulb included (only 230V)



## Holonzki

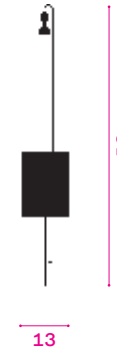

DESIGNER Eckard Knuth, Ingo Maurer  
YEAR 2000  
MATERIAL Glass, steel  
COLOR black  
LIGHT SOURCES GU4, Light bulb included



## Delight

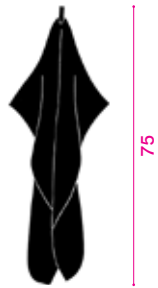

DESIGNER Frans van Nieuwenborg,  
Martijn Wegman  
YEAR 1980  
MATERIAL Glass fabric, plastic  
COLOR White  
LIGHT SOURCES E27

Suitable for EEC A-G

## Light au Lait

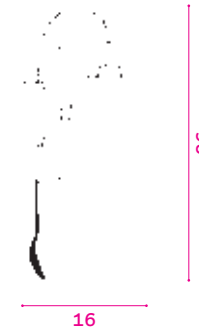

DESIGNER Fabien Dumas,  
Ingo Maurer & Team  
YEAR 2004  
MATERIAL Stoneware, silicone,  
stainless steel  
COLOR White  
LIGHT SOURCES G9

Suitable for EEC A-G

## Eclipse Ellipse

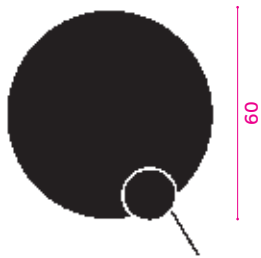

DESIGNER Ingo Maurer & Team  
YEAR 2017  
MATERIAL Aluminum, steel  
COLOR White  
LIGHT SOURCES LED integrated



## Lucellino Doppio

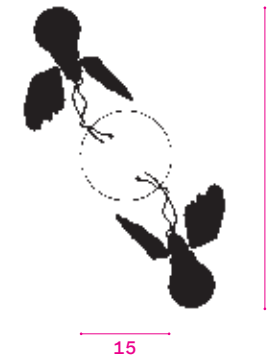

DESIGNER Ingo Maurer  
YEAR 2018 / 2022  
MATERIAL Goose feathers, plastic, brass  
COLOR White  
LIGHT SOURCES E27, Light bulbs included



## Lucellino NT

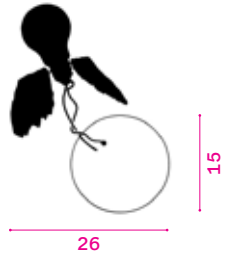

DESIGNER Ingo Maurer  
YEAR 1992 / 2022  
MATERIAL Goose feathers, plastic, brass  
COLOR White  
LIGHT SOURCES E27, Light bulb included



## Lucellino Wall



DESIGNER Ingo Maurer  
YEAR 1992 / 2022  
MATERIAL Goose feathers, plastic, brass  
COLOR White  
LIGHT SOURCES E27, Light bulb included



## Luzy On The Wall

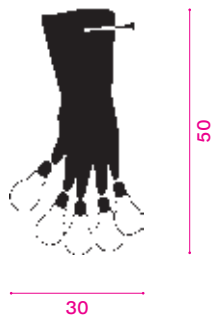

DESIGNER Ingo Maurer & Team  
YEAR 2018  
MATERIAL Nitrile (rubber), brass, plastic  
COLOR Blue  
LIGHT SOURCES E27, Light bulbs included



## Max. Mover

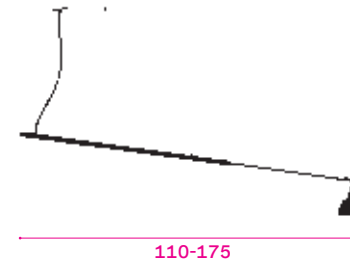

DESIGNER Ingo Maurer  
YEAR 2000 / 2017  
MATERIAL Steel, plastic, aluminum  
COLOR Black and chrome  
LIGHT SOURCES LED integrated



## Measure Light

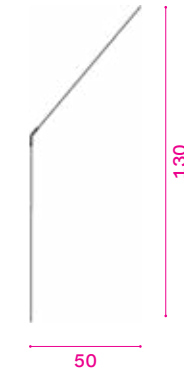

DESIGNER Josua Roters  
YEAR 2023  
MATERIAL Steel, plastic  
COLOR White and transparent  
LIGHT SOURCES LED integrated



## Ms. Bowjangles Wall



DESIGNER Anna Boch & David Engelhorn  
YEAR 2023  
MATERIAL Plastic, aluminum  
COLOR Black, orange  
LIGHT SOURCES LED integrated



## Ms. Bowjangles Tall Wall

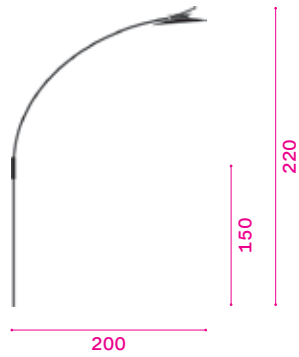

DESIGNER Anna Boch & David Engelhorn  
YEAR 2023  
MATERIAL Plastic, aluminum  
COLOR Black, orange  
LIGHT SOURCES LED integrated



## MOODMOON

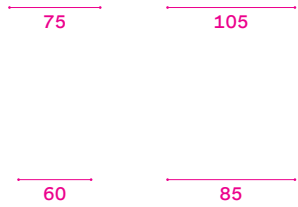

DESIGNER Sebastian Hepting  
YEAR 2021  
MATERIAL Paper, steel  
COLOR White  
LIGHT SOURCES LED integrated



## MOODMOON White

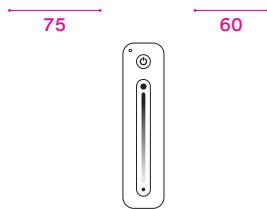

Remote control

DESIGNER Sebastian Hepting  
YEAR 2021  
MATERIAL Paper, steel  
COLOR White  
LIGHT SOURCES LED integrated



## OOP's

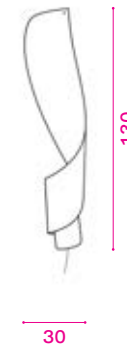

DESIGNER Ingo Maurer & Team  
YEAR 2019  
MATERIAL Paper, steel  
COLOR White  
LIGHT SOURCES E27

Suitable for EEC A-G

## OOP's 2

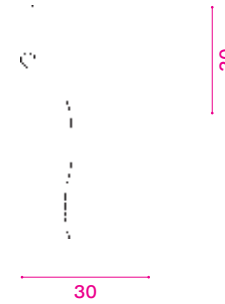

DESIGNER Ingo Maurer & Team  
YEAR 2019  
MATERIAL Paper, steel  
COLOR White  
LIGHT SOURCES GU10

Suitable for EEC A-G

## Oskar

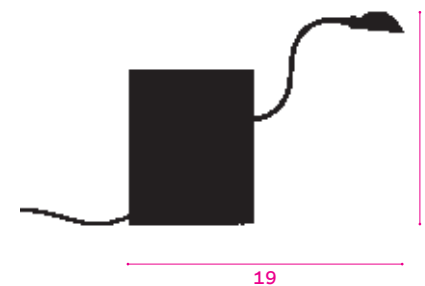

DESIGNER Ingo Maurer & Team  
YEAR 1998 / 2019  
MATERIAL Aluminum, silver  
COLOR Silver  
LIGHT SOURCES LED integrated



## Use Me W.

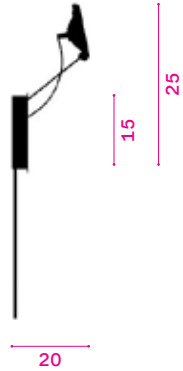

DESIGNER Ingo Maurer & Team  
YEAR 2010  
MATERIAL Aluminum, stainless steel  
COLOR Silver  
LIGHT SOURCES G53

Suitable for EEC A-G

## 24 Karat Blau M

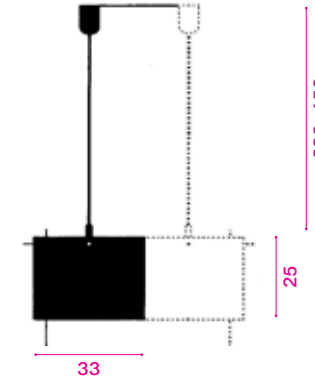

DESIGNER Axel Schmid  
YEAR 2005  
MATERIAL Gold leaf, plastic, steel  
COLOR Red  
LIGHT SOURCES E27

Suitable for EEC A-G

# HANGING & CEILING

## 18 x 18

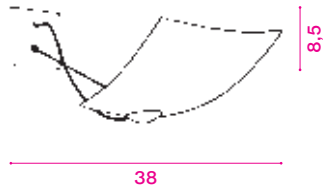

DESIGNER Ingo Maurer & Team  
YEAR 2015  
MATERIAL Aluminum, steel  
COLOR White  
LIGHT SOURCES LED integrated



## 24 Karat Blau

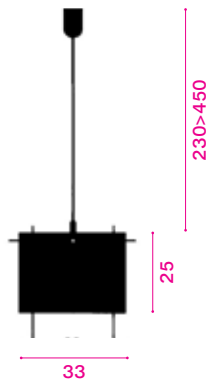

DESIGNER Axel Schmid  
YEAR 2005  
MATERIAL Gold leaf, plastic, steel  
COLOR Red  
LIGHT SOURCES E27

Suitable for EEC A-G

## 1000 Karat Blau

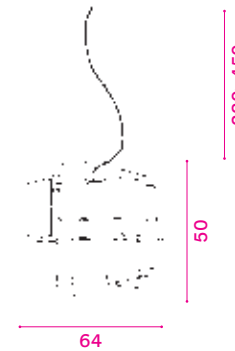

DESIGNER Axel Schmid  
YEAR 2009 / 2016  
MATERIAL Gold leaf, plastic, steel  
COLOR Red  
LIGHT SOURCES E27

Suitable for EEC A-G

## Birdie

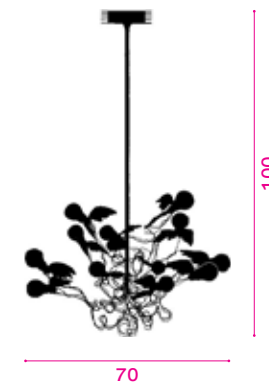

DESIGNER Ingo Maurer  
YEAR 2002 / 2017  
MATERIAL Steel, copper, goose feathers  
COLOR Silver  
LIGHT SOURCES E27 light bulbs included



## Birdie's Nest



DESIGNER Ingo Maurer  
YEAR 2005 / 2017  
MATERIAL Steel, copper, goose feathers  
COLOR White  
LIGHT SOURCES E27 light bulbs included



## Birds Birds Birds



DESIGNER Ingo Maurer  
YEAR 1992 / 2018  
MATERIAL Brass, copper, aluminum, goose feathers  
COLOR Silver  
LIGHT SOURCES E27 light bulbs included



## Blue Luzy



DESIGNER Ingo Maurer & Team  
YEAR 2018  
MATERIAL Nitrile (rubber), brass, plastic  
COLOR Blue  
LIGHT SOURCES E27 light bulb included



## Campari Light



DESIGNER Raffaele Celentano  
YEAR 2002  
MATERIAL Plastic, glass  
COLOR Red and transparent  
LIGHT SOURCES E27

Suitable for EEC A-G

## Canned Light



DESIGNER Christoph Matthias, Hagen Szczech  
YEAR 2003  
MATERIAL Tinplate, aluminum, plastic  
COLOR White + red  
LIGHT SOURCES GU10, light bulb included (only 230V)



## Floatation



DESIGNER Ingo Maurer  
YEAR 1980  
MATERIAL Paper, steel, natural, red ring  
COLOR white canopy  
LIGHT SOURCES E27

Suitable for EEC A-G

## Fly Candle Fly!

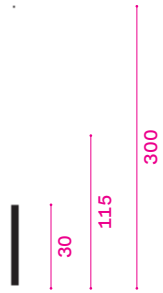

DESIGNER Georg Baldele & Team  
YEAR 1996  
MATERIAL Wax  
COLOR White

## Johnny B. Bald



DESIGNER Ingo Maurer  
YEAR 2020  
MATERIAL Metal, PTFE, plastic  
COLOR White  
LIGHT SOURCES E27



## Flying Flames

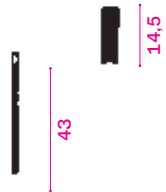

DESIGNER Moritz Waldemeyer,  
Ingo Maurer & Team  
YEAR 2013  
MATERIAL Aluminium, plastic, steel  
COLOR Candle element red,  
black, white  
LIGHT SOURCES LED integrated

## Johnny B. Butterfly

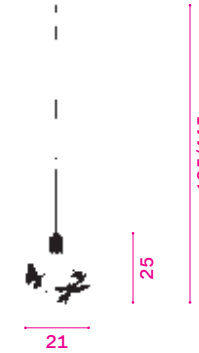

DESIGNER Ingo Maurer  
YEAR 2011  
MATERIAL Metal, PTFE, plastic  
COLOR White  
LIGHT SOURCES E27



## Hot Achille



DESIGNER Ingo Maurer & Team  
YEAR 1994 / 2019  
MATERIAL Stainless steel, aluminum  
COLOR Silver  
LIGHT SOURCES LED integrated



## Johnny B. Good



DESIGNER Ingo Maurer,  
Bernhard Dessecker  
YEAR 2002  
MATERIAL Glass, PTFE, plastic  
COLOR Transparent and white  
LIGHT SOURCES E27



## Knitterling

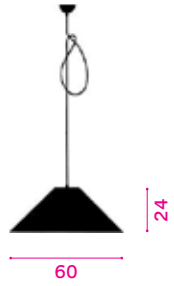

DESIGNER Ingo Maurer  
YEAR 1978  
MATERIAL Paper, steel, plastic  
COLOR Natural, canopy and cable black  
LIGHT SOURCES E27

Suitable for EEC A-G

## Lil Luxury

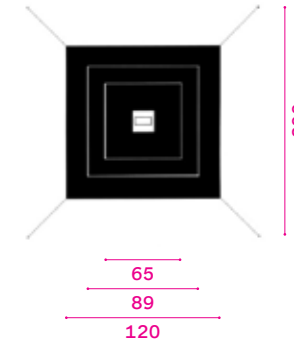

DESIGNER Ingo Maurer & Team  
YEAR 2009  
MATERIAL Paper, steel  
COLOR Gold, white  
LIGHT SOURCES GU10

Suitable for EEC A-G

## Lacrime del Pescatore

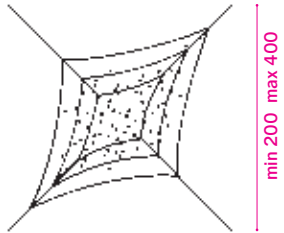

DESIGNER Ingo Maurer  
YEAR 2009  
MATERIAL Glass, nylon, stainless steel  
COLOR Transparent and silver  
LIGHT SOURCES G53

Suitable for EEC A-G

## Lil Luxury 2

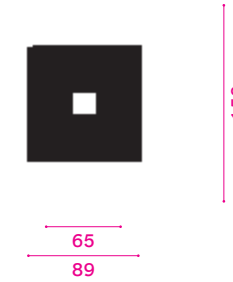

DESIGNER Ingo Maurer & Team  
YEAR 2020  
MATERIAL Paper, steel  
COLOR Gold, white  
LIGHT SOURCES GU10

Suitable for EEC A-G

## La Festa delle Farfalle

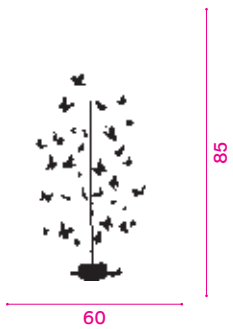

DESIGNER Ingo Maurer & Team  
YEAR 2019  
MATERIAL Steel, plastic, paper  
COLOR White  
LIGHT SOURCES LED integrated



## Lucellino Doppio

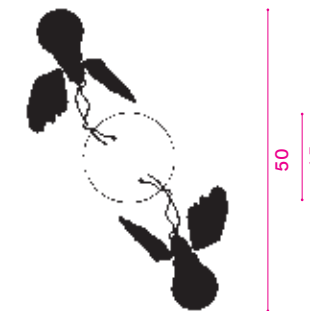

DESIGNER Ingo Maurer  
YEAR 2018 / 2022  
MATERIAL Goose feathers, plastic, brass  
COLOR White  
LIGHT SOURCES E27, Light bulbs included



## Luzy Take Five

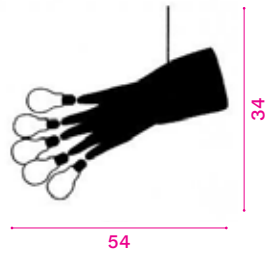

DESIGNER Ingo Maurer & Team  
YEAR 2018  
MATERIAL Nitrile (rubber), brass, plastic  
COLOR Blue  
LIGHT SOURCES E27, Light bulbs included



## One New Flame

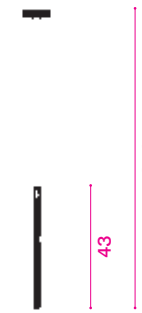

DESIGNER Moritz Waldemeyer,  
Ingo Maurer & Team  
YEAR 2013  
MATERIAL Circuit board, metal, plastic  
COLOR Candle element black,  
red, white, canopy white  
LIGHT SOURCES LED integrated

## Maru

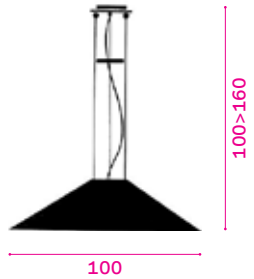

DESIGNER Ingo Maurer  
YEAR 1980  
MATERIAL Paper, steel, natural  
COLOR White canopy, red ring  
LIGHT SOURCES E27

Suitable for EEC A-G

## pic-a-stic

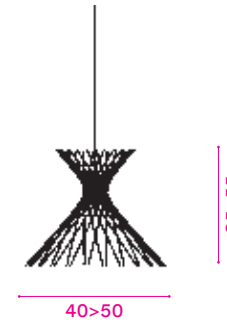

DESIGNER Andreas Walther  
YEAR 2022  
MATERIAL Glass, wood, plastic  
COLOR Sticks black and white,  
bright red and bright  
orange and blue  
LIGHT SOURCES GU10

Suitable for EEC A-G

## Max. Mover

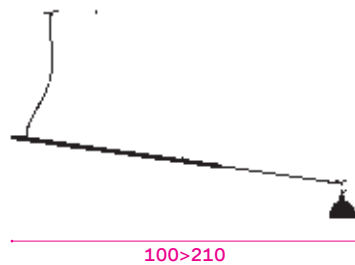

DESIGNER Ingo Maurer  
YEAR 2000 / 2017  
MATERIAL Steel, plastic, aluminum  
COLOR Black and chrome  
LIGHT SOURCES LED integrated



## Reality



DESIGNER Theo Möller  
YEAR 2023  
MATERIAL Eggshell, white, copper  
COLOR Natural white  
LIGHT SOURCES LED bulb included

## Signature

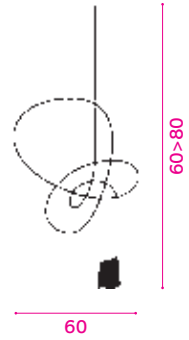

DESIGNER Ingo Maurer Team  
YEAR 2023  
MATERIAL Aluminum, plastic  
COLOR Black  
LIGHT SOURCES GU10

Suitable for EEC A-G

## Spock



DESIGNER Bernhard Dessecker  
YEAR 1998  
MATERIAL Glass, aluminum, stainless steel  
COLOR Transparent  
LIGHT SOURCES E27

Suitable for EEC A-G

## Signature Set

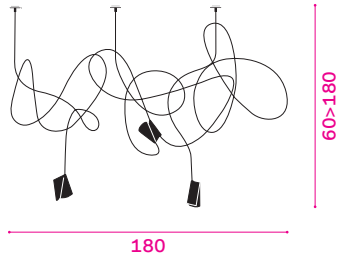

DESIGNER Ingo Maurer Team  
YEAR 2023  
MATERIAL Aluminum, plastic  
COLOR Black  
LIGHT SOURCES GU10

Suitable for EEC A-G

## Tubular

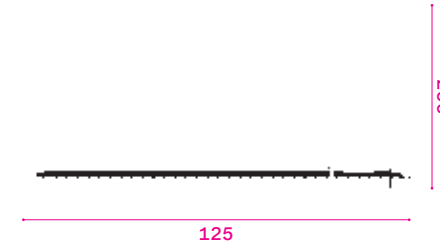

DESIGNER Sebastian Hepting  
YEAR 2020  
MATERIAL Glass, aluminum, steel  
COLOR Red LED unit and cable, white LED unit and blue cable  
LIGHT SOURCES LED integrated



## Schlitz Up



DESIGNER Ingo Maurer  
YEAR 2002  
MATERIAL GRP  
COLOR White  
LIGHT SOURCES LED bulbs included (only 230V)



## Use Me C.



DESIGNER Ingo Maurer & Team  
YEAR 2010  
MATERIAL Steel, aluminum  
COLOR White  
LIGHT SOURCES G53

Suitable for EEC A-G

## WillyDilly

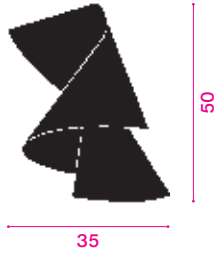

DESIGNER Ingo Maurer  
YEAR 1983  
MATERIAL Paper, stainless steel, plastic  
COLOR White  
LIGHT SOURCES E27

Suitable for EEC A-G

## Zettel'Z 6



DESIGNER Ingo Maurer  
YEAR 1998  
MATERIAL Paper, stainless steel  
COLOR Natural white  
LIGHT SOURCES E27

Suitable for EEC A-G

## Zettel'Z 5

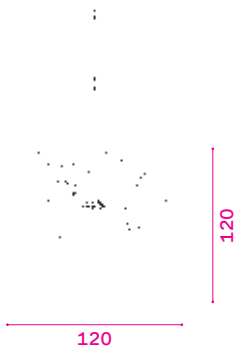

DESIGNER Ingo Maurer  
YEAR 1997  
MATERIAL Paper, stainless steel  
COLOR Natural white  
LIGHT SOURCES E27

Suitable for EEC A-G

## Zuuk

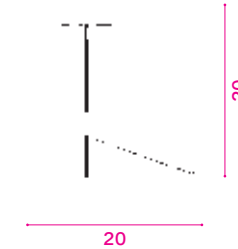

DESIGNER Ingo Maurer  
YEAR 1994  
MATERIAL Glass, aluminum, silver  
COLOR Silver  
LIGHT SOURCES B15d

Suitable for EEC A-G

## Zettel'Z 5 Laughing Buddha



DESIGNER Ingo Maurer  
YEAR 1997 / 2018  
MATERIAL Paper, stainless steel  
COLOR Natural white  
LIGHT SOURCES E27

Suitable for EEC A-G

# SYSTEMS

## Bakarù



32

DESIGNER Ingo Maurer & Team  
YEAR 1986  
MATERIAL Stainless steel, plastic, silicone  
COLOR Silver and White  
LIGHT SOURCES GU5,3

Suitable for EEC A-G

## YaYaHo Element 1



100

DESIGNER Ingo Maurer & Team  
YEAR 1984  
MATERIAL Glass, stainless steel  
COLOR Red and white  
LIGHT SOURCES G4

Suitable for EEC A-G

## YaYaHo Element 2



75

DESIGNER Ingo Maurer & Team  
YEAR 1984  
MATERIAL Stainless steel, brass  
COLOR Silver  
LIGHT SOURCES GU(X)5,3

Suitable for EEC A-G

## YaYaHo Element 3



75

DESIGNER Ingo Maurer & Team  
YEAR 1984  
MATERIAL Stainless steel, plastic, silicone  
COLOR Black  
LIGHT SOURCES GU(X)5,3

Suitable for EEC A-G

## YaYaHo Element 4/5



75

DESIGNER Ingo Maurer & Team  
YEAR 1984  
MATERIAL Porcelain, stainless steel, plastic  
COLOR Silver and white, cover red, blue  
LIGHT SOURCES GY6,35 Light source integrated



## YaYaHo Element 6



100

DESIGNER Ingo Maurer & Team  
YEAR 1984  
MATERIAL Stainless steel, silicone  
COLOR White and Silver  
LIGHT SOURCES GU(X)5,3

Suitable for EEC A-G

## YaYaHo Element 14



75

DESIGNER Ingo Maurer & Team  
YEAR 2011  
MATERIAL Silicone, stainless steel  
COLOR Silver and white  
LIGHT SOURCES GY6,35 Light bulb included



## YaYaHo Element 16



92

DESIGNER Ingo Maurer & Team  
YEAR 2011  
MATERIAL Silicone, stainless steel  
COLOR Silver and white  
LIGHT SOURCES GU(X)5,3

Suitable for EEC A-G

## YaYaHo Element 77



75

DESIGNER Ingo Maurer & Team  
YEAR 1984  
MATERIAL Silicone, stainless steel, plastic  
COLOR Silver and white  
LIGHT SOURCES GU(X)5,3

Suitable for EEC A-G

# MAMO NOUCHIES

## Babadul

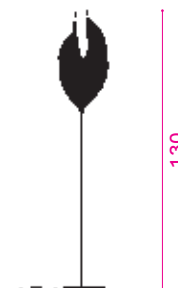

130

DESIGNER Dagmar Mombach,  
Ingo Maurer & Team  
YEAR 2017  
MATERIAL Paper, steel, stainless steel,  
natural (white), anthracite base  
COLOR  
LIGHT SOURCES LED integrated



## Kokoro



80

DESIGNER Dagmar Mombach,  
Ingo Maurer & Team  
YEAR 1998  
MATERIAL Paper, steel, stainless steel  
COLOR Red, anthracite base  
LIGHT SOURCES LED integrated



## Poul Poul



40

70

DESIGNER Dagmar Mombach,  
Ingo Maurer & Team  
YEAR 1998  
MATERIAL Paper, steel, stainless steel  
COLOR Natural (white), anthracite  
base  
LIGHT SOURCES LED integrated



## Samurai



DESIGNER Dagmar Mombach,  
Ingo Maurer & Team  
YEAR 1998  
MATERIAL Paper, steel, stainless steel,  
COLOR Natural (white), anthracite base  
LIGHT SOURCES LED integrated



## Wo-Tum-Bu 2



DESIGNER Dagmar Mombach,  
Ingo Maurer & Team  
YEAR 1999  
MATERIAL Paper, concrete, stainless steel  
COLOR Natural (white), gray base  
LIGHT SOURCES LED integrated



## Walking in the Rain

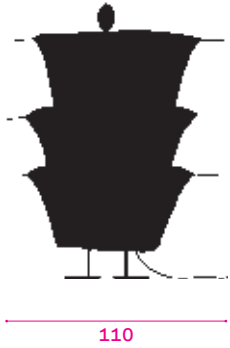

DESIGNER Dagmar Mombach,  
Ingo Maurer & Team  
YEAR 2017  
MATERIAL Paper, steel, plastic  
COLOR Natural (white), red base  
LIGHT SOURCES LED integrated



## Yoruba Rose Table



DESIGNER Dagmar Mombach,  
Ingo Maurer & Team  
YEAR 2017  
MATERIAL Paper, concrete, stainless steel  
COLOR Natural (white), anthracite base  
LIGHT SOURCES LED integrated



## Wo-Tum-Bu 1



DESIGNER Dagmar Mombach,  
Ingo Maurer & Team  
YEAR 1999  
MATERIAL Paper, concrete, stainless steel  
COLOR Natural (white), gray base  
LIGHT SOURCES LIGHT SOURCES E27

Suitable for EEC A-G

## Yoruba Rose Floor

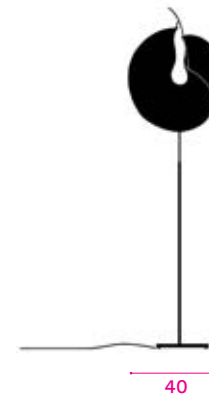

DESIGNER Dagmar Mombach,  
Ingo Maurer & Team  
YEAR 2020  
MATERIAL Paper, concrete, stainless steel  
COLOR Natural (white), anthracite base  
LIGHT SOURCES LED integrated



**IN**

**DEX**

# O

---

1000 Karat Blau <sup>146</sup>  
18 × 18 <sup>102 / 142</sup>  
24 Karat Blau <sup>144</sup>  
24 Karat Blau Flat <sup>105</sup>  
24 Karat Blau Floor <sup>40</sup>  
24 Karat Blau M <sup>145</sup>  
24 Karat Blau T <sup>63</sup>  
24 Karat Blau W <sup>107</sup>

# B

---

Babadul <sup>242</sup>  
Bakarù <sup>226</sup>  
b.bulb <sup>69</sup>  
BIBIBIBI <sup>64</sup>  
Birdie <sup>148</sup>  
Birdie's Nest <sup>151</sup>  
Birdies Busch <sup>71</sup>  
Birds Birds Birds <sup>153</sup>  
Blue Luzy <sup>154</sup>  
Bruce Springsteel <sup>31</sup>  
Bulb <sup>66</sup>  
Bulb Brass <sup>67</sup>

# C

---

Campari Bar <sup>73</sup>  
Campari Light <sup>157</sup>  
Canned Light <sup>161</sup>

# D

---

Delight <sup>111</sup>

# E

---

Eclipse Ellipse <sup>112</sup>

# F

---

Floatation <sup>162</sup>  
Fly Candle Fly <sup>167</sup>  
Flying Flames <sup>168</sup>

# H

---

Holonzki <sup>114</sup>  
Hot Achille <sup>170</sup>

# I

---

I Ricchi Poveri Bzzzz <sup>74</sup>  
I Ricchi Poveri Monument  
for a Bulb <sup>75</sup>  
I Ricchi Poveri Toto <sup>77</sup>  
Ilios <sup>42</sup>

# J

---

Jasna Kuchnia <sup>27</sup>  
Johnny B. Bald <sup>172</sup>  
Johnny B. Butterfly <sup>173</sup>  
Johnny B. Good <sup>175</sup>

# K

---

Kamishibai <sup>81</sup>  
Knitterling <sup>177</sup>  
Kokoro <sup>246</sup>  
Koyoo <sup>83</sup>

# L

---

La Festa delle Farfalle <sup>182</sup>  
Lacrime del Pescatore <sup>179</sup>  
Lampampe <sup>84</sup>  
Light au Lait <sup>118</sup>  
Lil Luxury <sup>185</sup>  
Lil Luxury 2 <sup>184</sup>  
Lucellino Doppio <sup>121 / 187</sup>  
Lucellino Tisch <sup>88</sup>  
Lucellino Touch <sup>88</sup>  
Lucellino Wall <sup>121</sup>  
Luzy On The Wall <sup>123</sup>  
Luzy Take Five <sup>189</sup>

# M

---

Maru <sup>191</sup>  
Max. Floor <sup>45</sup>  
Max. Kugler <sup>90</sup>  
Max. Mover <sup>124 / 192</sup>  
Measure Light <sup>127</sup>  
Moodmoon <sup>130</sup>  
Moodmoon Framed <sup>47</sup>  
Moodmoon White <sup>130</sup>  
Mozzkito <sup>94</sup>  
Ms. Bowjangles <sup>49</sup>  
Ms. Bowjangles Tall <sup>50</sup>  
Ms. Bowjangles Wall <sup>134</sup>  
Ms. Bowjangles Wall Tall <sup>134</sup>  
My New Flame <sup>93</sup>

# N

---

NALUM <sup>18</sup>  
nuunu <sup>54</sup>

# O

---

One From The Heart <sup>96</sup>  
One New Flame <sup>195</sup>  
OOP's <sup>137</sup>  
OOP's 2 <sup>136</sup>  
Oskar <sup>117</sup>

# P

---

Pic-a-Stic <sup>196</sup>  
Poul Poul <sup>249</sup>

# R

---

Reality <sup>200</sup>  
Ringelpiez Floor <sup>59</sup>

# S

---

Samurai <sup>259</sup>  
Schlitz Up <sup>206</sup>  
Shhh! <sup>22</sup>  
Signature <sup>202</sup>  
Signature Set 3 <sup>203</sup>  
Spock <sup>208</sup>  
Strange Little Thing <sup>34</sup>

# T

---

Tubular <sup>210</sup>  
Tubular Balance <sup>98</sup>

# U

---

Use Me C. <sup>212</sup>  
Use Me W. <sup>139</sup>

# W

---

Walking in the Rain <sup>261</sup>  
WillyDilly <sup>214</sup>  
Wo-Tum-Bu 1 <sup>262</sup>  
Wo-Tum-Bu 2 <sup>265</sup>

# Y

---

YaYaHo <sup>230</sup>  
Yoruba Rose Floor <sup>266</sup>  
Yoruba Rose Table <sup>269</sup>

# Z

---

Zettel'Z 5 <sup>216</sup>  
Zettel'Z 5 Laughing  
Buddha <sup>218</sup>  
Zettel'Z 6 <sup>221</sup>  
Zuuk <sup>222</sup>



# EDI



# TIONS



**Transforming spaces  
through emotional  
and visual power.**

COMIC EXPLOSION<sub>10</sub>

FLATTERBY<sub>16</sub>

FLYING DISC<sub>22</sub>

I RICCHI POVERI

FIVE BUTTERFLIES<sub>28</sub>

LED BENCH /

LED TABLE<sub>32</sub>

LUCE VOLANTE<sub>38</sub>

LUSTER<sub>42</sub>

OH MAN IT'S A RAY!<sub>46</sub>

OH MEI MA<sub>52</sub>

OH MEI MA KABIR<sub>58</sub>

PIERRE OU PAUL<sub>64</sub>

PULSATING LED

HEART

XXL DOME<sub>74</sub>

# COMIC EXPLOSION 2010

A burst of light caught in mid-air: sharp, fragmented forms radiate brightness and shadow, animating the room with raw energy. Downward and upward glow combine with luminous arrows to create layers of contrast, so the atmosphere is never static but charged with movement. More than a luminaire, it is a sculptural event — bold, playful, impossible to ignore. Especially powerful in cultural venues, statement lobbies or hospitality settings that thrive on identity, it transforms space into a scene of impact and surprise.

Calibrate the drama

Special sizes developed to your dimensions—  
from intimate to monumental.







# FLATTERBY 2016

Suspended in mid-flight, delicate wings circle a glowing source, scattering reflections and soft shadows that set the room gently in motion. The installation adds lightness and poetry to architecture, softening strict geometries with a sense of wonder. Each piece is numbered and crafted as a collector's object, ensuring rarity and distinction.

Curate the swarm

Different insects and colour variations allow alignment with thematic concepts, turning every edition into a personal signature within the project.





**Bulb Gigante.**

A special design of the Flatterby, in a custom-made, even larger version for an exclusive wine hotel in Tsinandali, Georgia.



# FLYING DISC 2016

A disc of light that seems to float beneath the ceiling, tethered only by fine wires and animated by geometry. The LED-ring breathes indirect illumination through the white diffuser, bending shadow and glow into a soft choreography—light that shapes without demanding. What feels weightless also demands precision: the angle of the ring, the drop of the stem, the interplay between disc and shadow define its presence. It's a statement piece for spaces that unfold in volume—soaring foyers, creative galleries or elevated dining rooms—where orientation and atmosphere are inseparable.

Tailored dimensions, tuned to architecture

With custom colours and proportions available, it can shift from subtle grace to bold form depending on what the space needs.



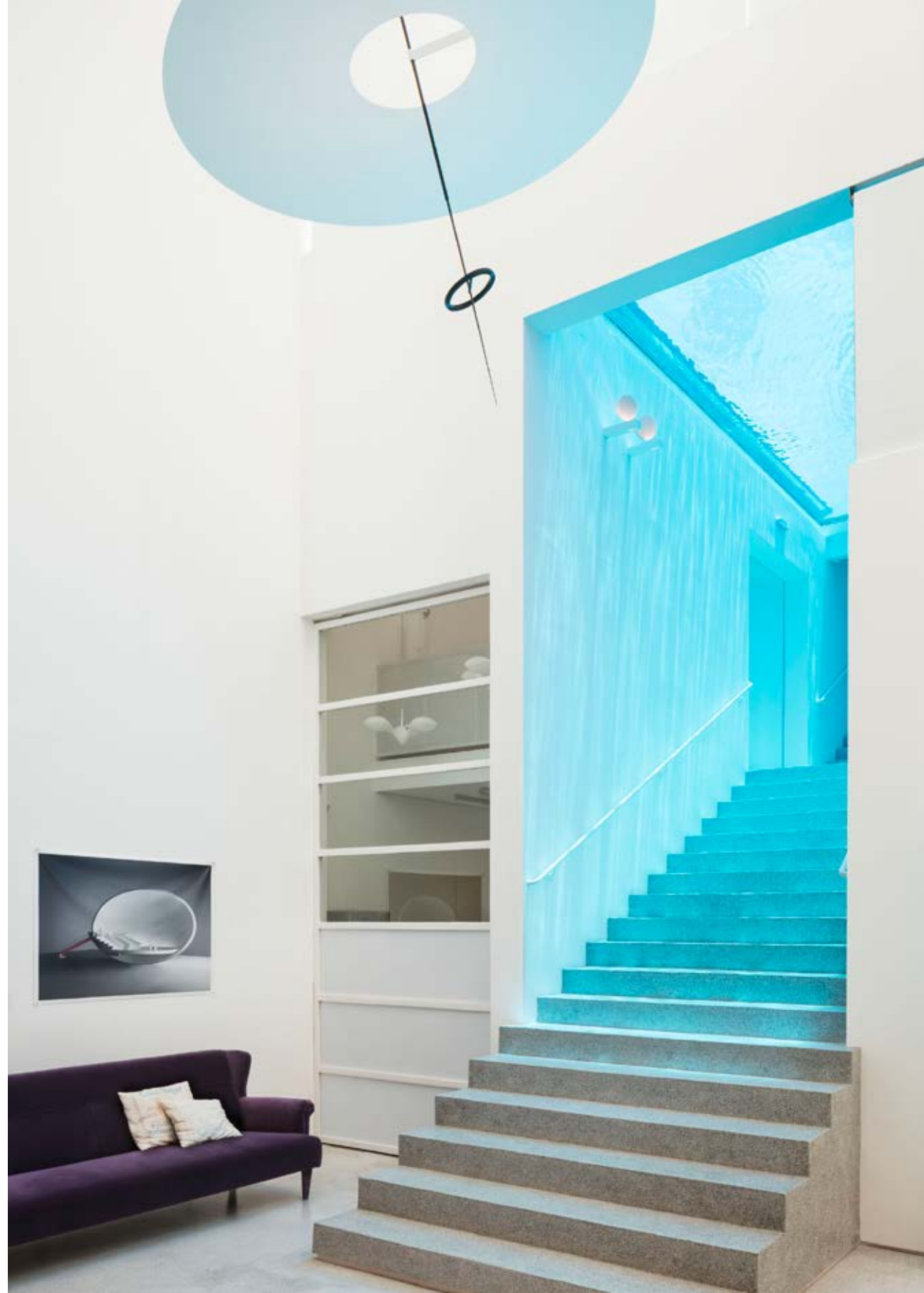



# I RICCHI POVERI FIVE BUTTERFLIES 2014

Five fragile wings orbit a glowing filament, as if light itself had drawn them into mid-flight. The scene feels tender and surreal: illumination becomes poetry, geometry dissolves into softness, and the atmosphere gains an intimacy no ordinary fixture could create. A light object and collector's treasure. Most at home in lounges, private salons or reading corners — settings where detail and atmosphere matter — it lends a quiet, poetic accent.

Compose the flight

On request, variations with different insects or colours align the gesture with concept and palette, making each piece a unique signature within architecture.





# LED BENCH & TABLE 2003

Light inhabits the furniture, turning benches and tables into radiant surfaces that seem to glow from within. They bring presence and atmosphere into foyers, lounges or intimate interiors, transforming the everyday act of gathering into an encounter with light. Each piece is realised as a unique work — available in different measures, colours, and with the table supported either by glass or metal. This freedom allows the objects to resonate with their surroundings, whether as subtle complement or striking centrepiece. Most at home in reception areas, creative workspaces or private dining rooms, they become luminous landmarks at the scale of human touch.







Led Bench 2003

# LUCE VOLANTE 2012/2018

Suspended as if by whisper, this piece floats like fabric releasing light. A generous downlight meets a halo above, the warm glow shaped by dim-to-warm LEDs that softly shift from candle-warm tones to more radiant warmth, all framed by glass-fiber surfaces and sleek aluminium edges. It softens ceilings, defines circulation, and creates calm without sacrifice — the light becomes part of the architecture, not just its ornament. Best placed where horizontal surfaces need clarity and calm — dining tables, counters, or meeting zones — it offers orientation and atmosphere in balance.

Colour it to context

Available in matt white or matt red, with custom colours possible, so the piece can blend into the palette or draw the eye as a singular accent.





# LÜSTER 2003

A floating chandelier in the truest sense, Lüster suspends itself with invisible cables and radiates soft, dual-sided light from 287 built-in LEDs, sculpting both volume and void. The glass is printed (red or black), with no visible wiring or boards—light appears to be the form itself. Its glow diffuses gently, animating ceilings and casting subtle ambient light downward and outward, so that large rooms feel warm and enveloping, while intimate spaces gain depth and elegance. In application, Lüster serves both as a centerpiece and as ambient enhancer — ideal above long dining tables, in grand foyers, or any high ceiling where formal drama and sculptural subtlety are desired. With custom measures and colour variants, it can be scaled and tuned to match ceiling height, room proportions, or specific design palettes.

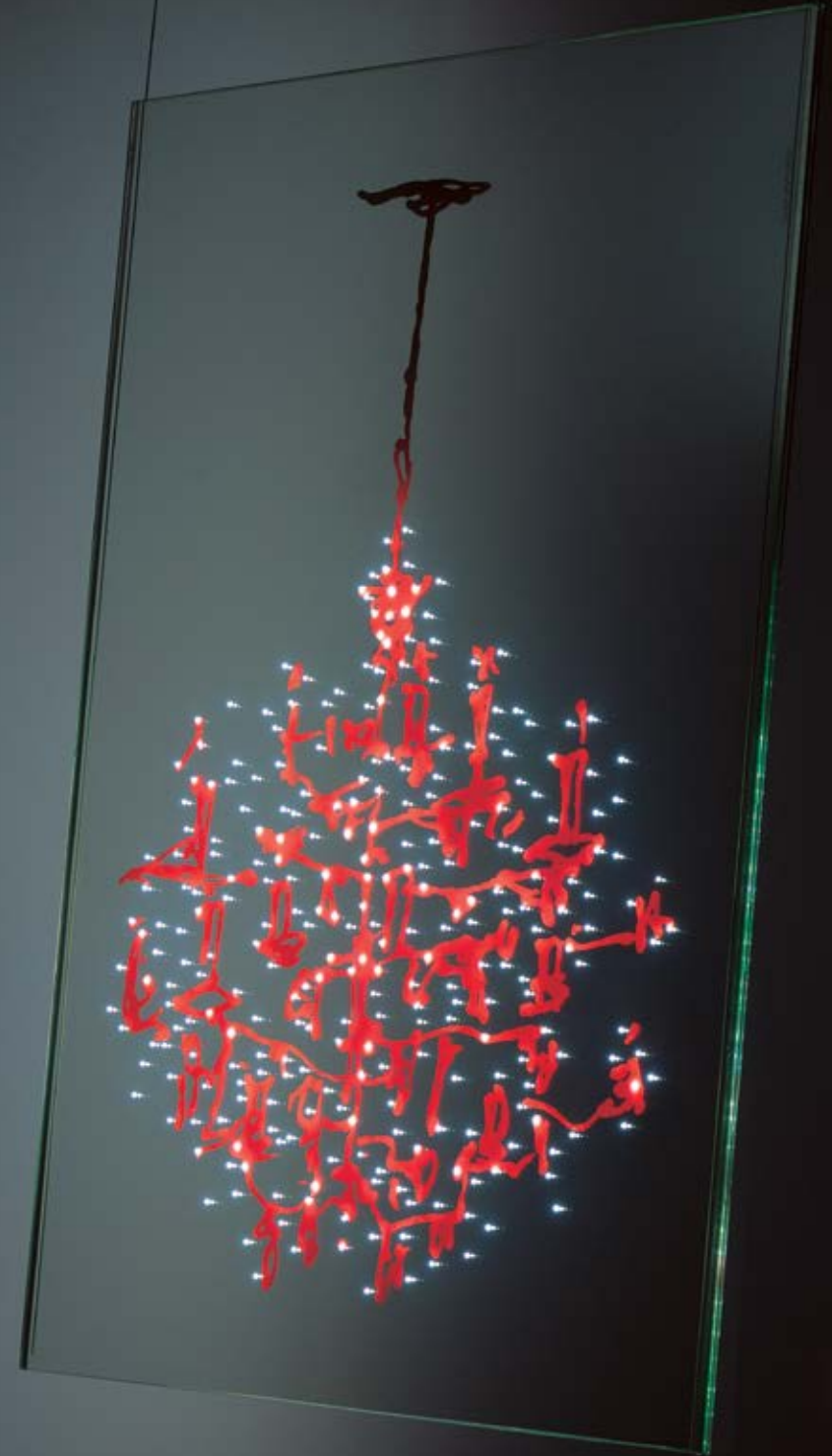



# OH MAN IT'S A RAY! 2009

Oh Man, It's a Ray! floats between chandelier and mobile, its wooden arms and glowing bulbs forming a radiant constellation. The layered light animates ceilings and creates shifting patterns of brightness and shadow, so that the object never feels static but alive. More than illumination, it introduces movement and warmth, softening the monumentality of large interiors. Particularly suited for cultural venues, creative workspaces or dining areas where a sense of play and openness is desired, it becomes a luminous centrepiece with a distinctly human touch.

The right hanger for every size

Customisable in form and available in different measures, it adapts effortlessly to diverse proportions and design concepts.

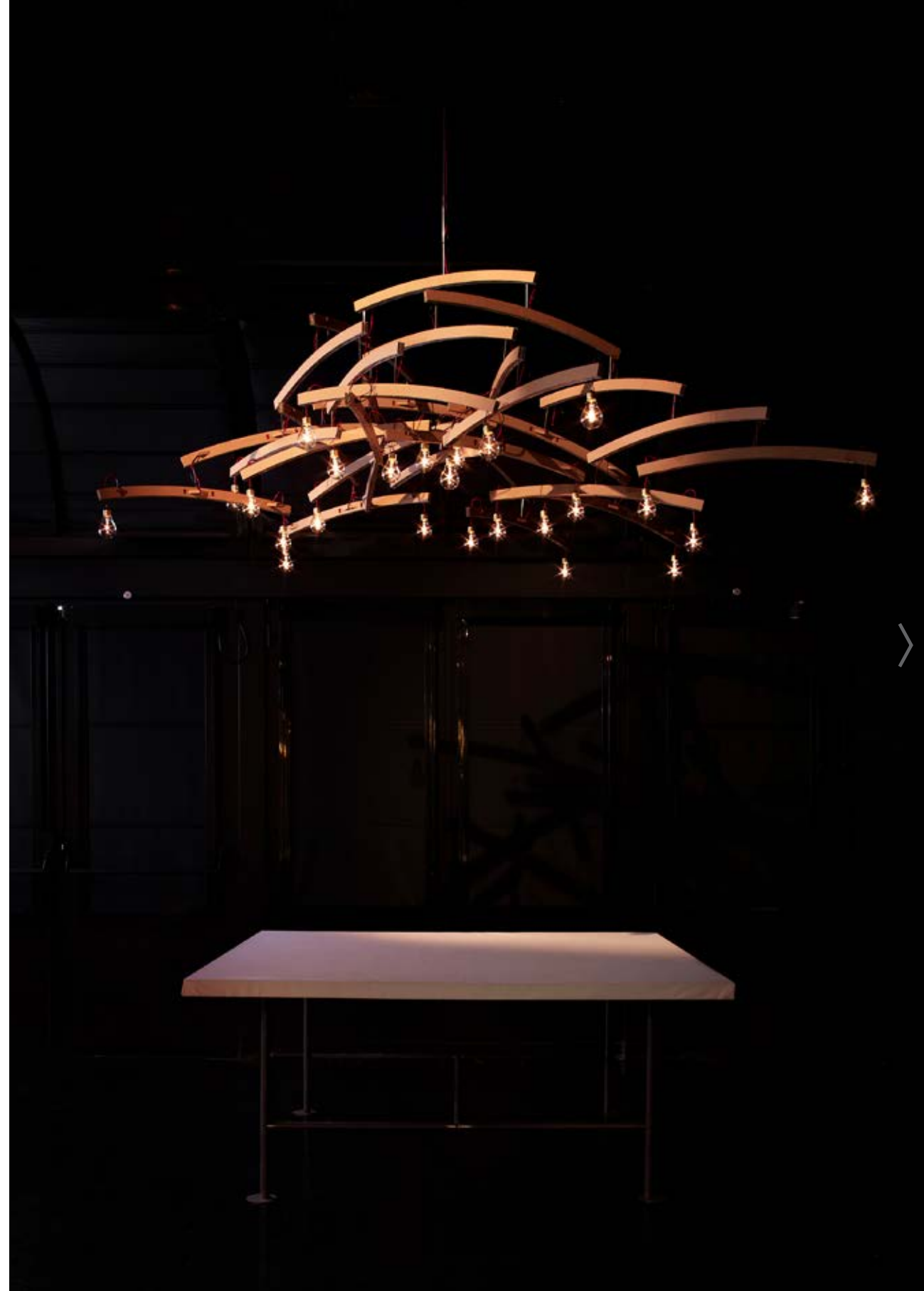





OH MAN, IT'S A RAY!

OH MAN, IT'S A RAY!

OH MAN, IT'S A RAY!

# OH MEI MA 1993

Like a sail caught in an invisible wind, broad golden planes float beneath the ceiling and turn light into pure theatre. Shadows and reflections shift across their surfaces, so the atmosphere is never static but alive with gentle radiance. It brings scale and drama to interiors while remaining serene and weightless, a luminous sculpture that crowns the space. Perfect for settings where light is expected to astonish as much as it illuminates, it transforms architecture into a stage for presence and emotion.

No edits. No options. Pure icon

Offered only in its original composition, it retains its unique power exactly as conceived.

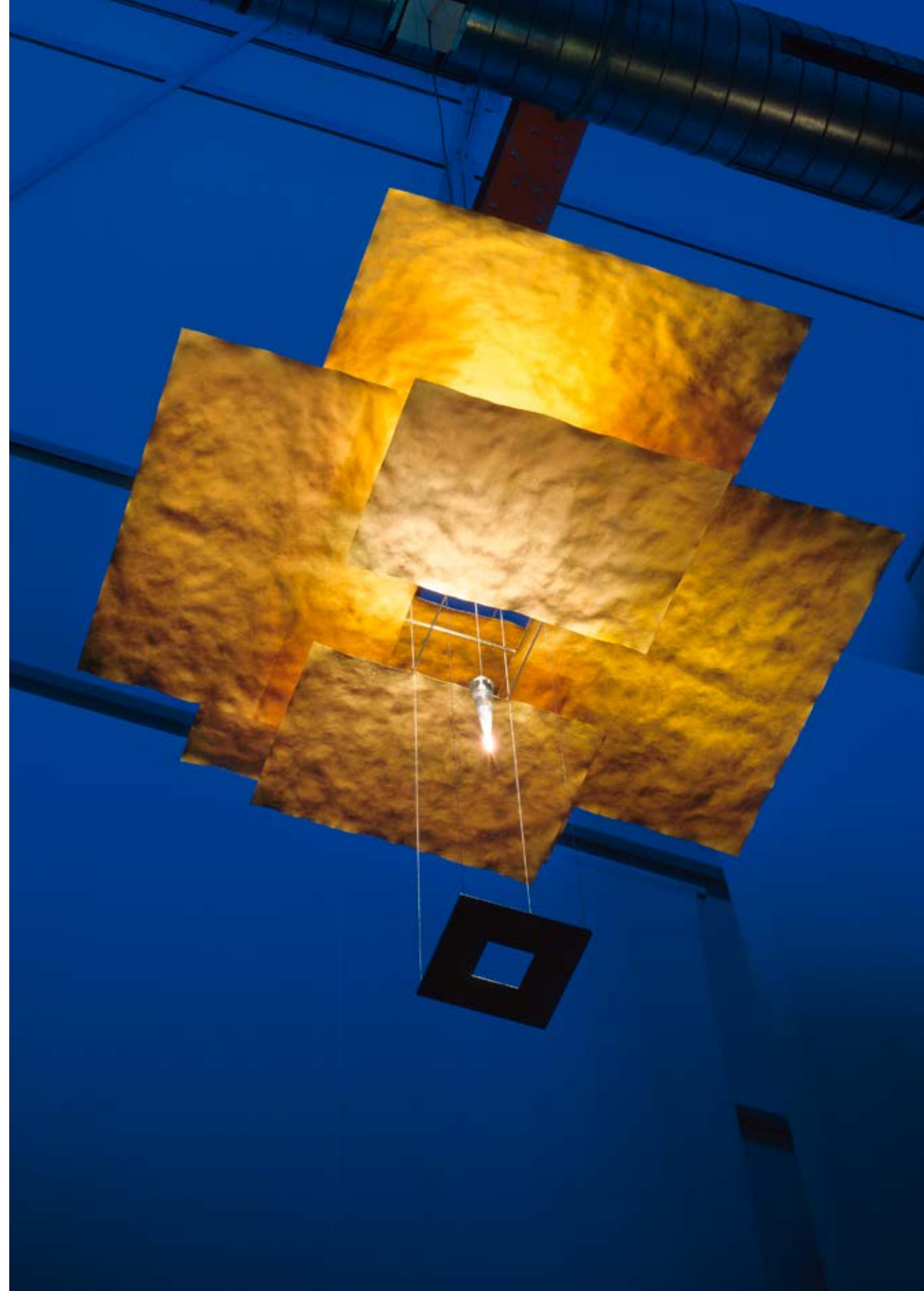





# OH MEI MA KABIR 1993

An expansion of the poetic gesture, the sails unfold here in monumental scale. Where the smaller version conveys intimacy and calm, this interpretation transforms high interiors with grandeur and presence. Layers of golden planes diffuse light into warm reflections and soft shadows, so the atmosphere remains weightless even at dramatic size. More than illumination, it crowns lobbies, halls or cultural venues as a luminous architecture in its own right.

Untouched. Just presence

Offered only in its original composition.







# PIERRE OU PAUL 1996

A sculptural dome of light, suspended with counterweights, that transforms ceiling into canvas and air into volume. Light glows from the underside with warm 2700K LEDs, while the inner surface—gold, platinum or matte lacquer—adds subtle radiance. The interplay of glow and shadow emphasizes the dome's curved clarity, guiding orientation, softening contours, and defining space with both presence and generosity. Ideal for expansive interiors where architecture meets ceremony—grand foyers, meeting halls or pooled dining zones—this piece frames the volumes around it and draws eyes upward in single gesture.

Scales shift, presence stays

Available in several diameters and standard finishes, with cable lengths customizable on request, this project offers flexibility in dimension and colour to suit the architectural scale and design palette.







# PULSATING LED HEART 2010

Suspended in space, the heart seems to breathe: glowing brighter, then softening, never still. The gentle rhythm gives the form an unexpected vitality, as if the room itself had found a pulse. Behind the effect, LEDs fade in and out with precision, transforming a simple contour into a living sign. Intimate yet unmistakable, it creates an atmosphere charged with emotion — poetic in private interiors, iconic in public space.

Each piece is unique as your heartbeat

Available in different sizes and colours, so the gesture can resonate with its architectural setting.





# XXL DOME 1999

A vast dome of light hovers overhead, like a captured piece of sky brought indoors. Its sheer scale astonishes, yet the glow it casts is soft and embracing, turning distance into intimacy and volume into coherence. More sculpture than fixture, it crowns the architecture with an otherworldly calm that cannot be ignored. Colours on request allow the inner world of the dome to shift mood — from quiet resonance to striking contrast — while its presence remains monumental and unmistakably singular.







**TECH  
NICAL**

**INFOR  
MATION  
TION**



## Comic Explosion



DESIGNER Ingo Maurer  
YEAR 2010  
MATERIAL Steel, aluminium, plastic  
COLOR White and fluo red  
LIGHT SOURCES LED integrated



## I Ricchi Poveri Five Butterflies



DESIGNER Ingo Maurer  
YEAR 2014 / 2022  
MATERIAL Steel, brass  
COLOR Anthracite base, brass, white butterflies  
LIGHT SOURCES E27 Light bulb included



## Flatterby

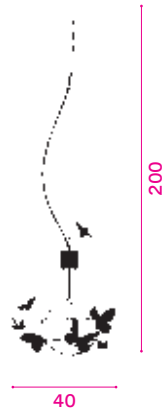

DESIGNER Ingo Maurer & Team  
YEAR 2016  
MATERIAL Glass, plastic, brass  
COLOR Black and white  
LIGHT SOURCES G9

Suitable for EEC A-G

## LED Table

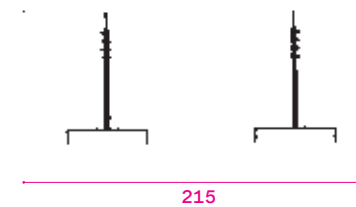

DESIGNER Ingo Maurer  
YEAR 2003  
MATERIAL Glass, metal  
COLOR Transparent  
LIGHT SOURCES 278 intergated white LEDs per panel



## Flying Disc

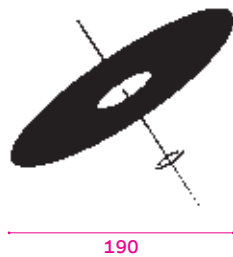

DESIGNER Ingo Maurer & Team  
YEAR 2016  
MATERIAL GRP, steel, plastic  
COLOR White and black  
LIGHT SOURCES LED integrated



## LED Bench



DESIGNER Ingo Maurer  
YEAR 2002  
MATERIAL Glass  
COLOR Transparent  
LIGHT SOURCES 288 integrated white LEDs



## Luce Volante



DESIGNER Ingo Maurer & Team  
YEAR 2012 / 2018  
MATERIAL GRP, steel  
COLOR Steel  
LIGHT SOURCES LED integrated



## Lüster

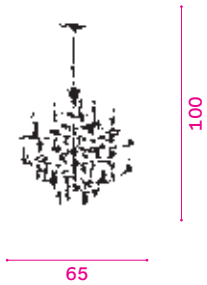

DESIGNER Ingo Maurer  
YEAR 2003  
MATERIAL Glass  
COLOR Transparent  
LIGHT SOURCES 287 integrated white LEDs



## Oh Man, It's a Ray!

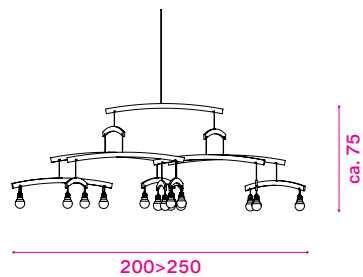

DESIGNER Ingo Maurer & Team  
YEAR 2010  
MATERIAL Wood, metal, glass  
COLOR Natural oiled wood, dark oiled (on request)  
LIGHT SOURCES E27 Light sources integrated



## Oh Mei Ma

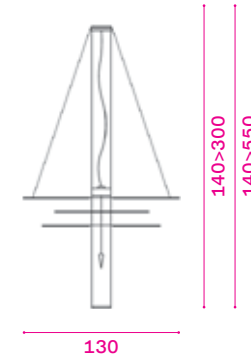

DESIGNER Ingo Maurer & Team  
YEAR 1993  
MATERIAL Aluminium + stainless steel, matte white painted aluminium sheets or gold plated paper leaves, silver (on request)  
COLOR Gold, matte white, silver (on request)  
LIGHT SOURCES LED integrated



## Oh Mei Ma Kabir

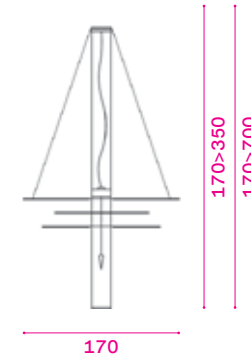

DESIGNER Ingo Maurer & Team  
YEAR 1997  
MATERIAL Aluminium + stainless steel, matte white painted aluminium sheets or gold plated paper leaves, silver (on request)  
COLOR Gold, matte white, silver (on request)  
LIGHT SOURCES LED integrated



## Pierre ou Paul

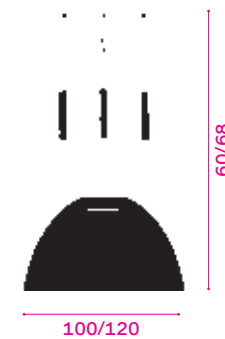

DESIGNER Ingo Maurer & Team  
YEAR 1996  
MATERIAL Aluminum, stainless steel  
COLOR outside bare aluminum inside gold plated, palladium plated, or fluorescent color, custom colors (on request)  
LIGHT SOURCES LED integrated



## Pulsating LED Heart

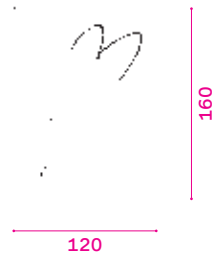

DESIGNER Ingo Maurer  
YEAR 2010  
MATERIAL Glass  
COLOR Transparent  
LIGHT SOURCES integrated red LEDs, pulsating

## XXL Dome

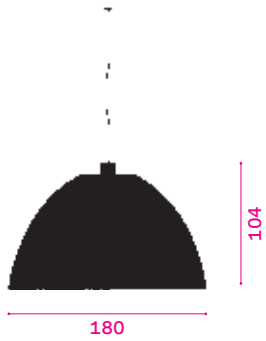

DESIGNER Ingo Maurer & Team  
YEAR 1999  
MATERIAL GRP + Steel  
COLOR outside silver painted  
inside fluorescent color,  
gold painted, custom colors  
(on request)  
LIGHT SOURCES LED integrated



CONCEPT AND DESIGNWORK

**CMFF.studio**

PHOTOGRAPHY

**Nomi Baumgartl**

**Chiara Bonetti**

**Maximilian Britz**

**Fabian Gruber**

**Giuliano Koren**

**Frank Koschembar**

**Jonathan Leijonhufvud**

**Erwin Olaf**

**Katharina Reichvilser**

**Anne Schwarzelt**

**Hagen Sczech**

**Markus Tollhopf**

**Tom Vack**

ILLUSTRATIONS

**Axel Schmid**

PRINTED BY

**Grafiche GFP**



**Ingo Maurer GmbH**

**Kaiserstrasse 47**

**80801 München**

**T +49 89 381 6060**

**info@ingo-maurer.com**

**ingo-maurer.com**

