



WHO HUNTER

WHO HUNTER

**Mit dieser Publikation möchten wir unsere neuen Ideen und die Vielfältigkeit unserer Arbeit zeigen:
Wir produzieren, erfinden, entwickeln, vertreiben, verkaufen, und planen große und kleine Projekte
+ vieles mehr**

**The objective of this publication is to show our new ideas and the enormous range of the work we do:
manufacturing, inventing and developing technical parts, distributing, selling, as well as planning large and small projects
+ much more**

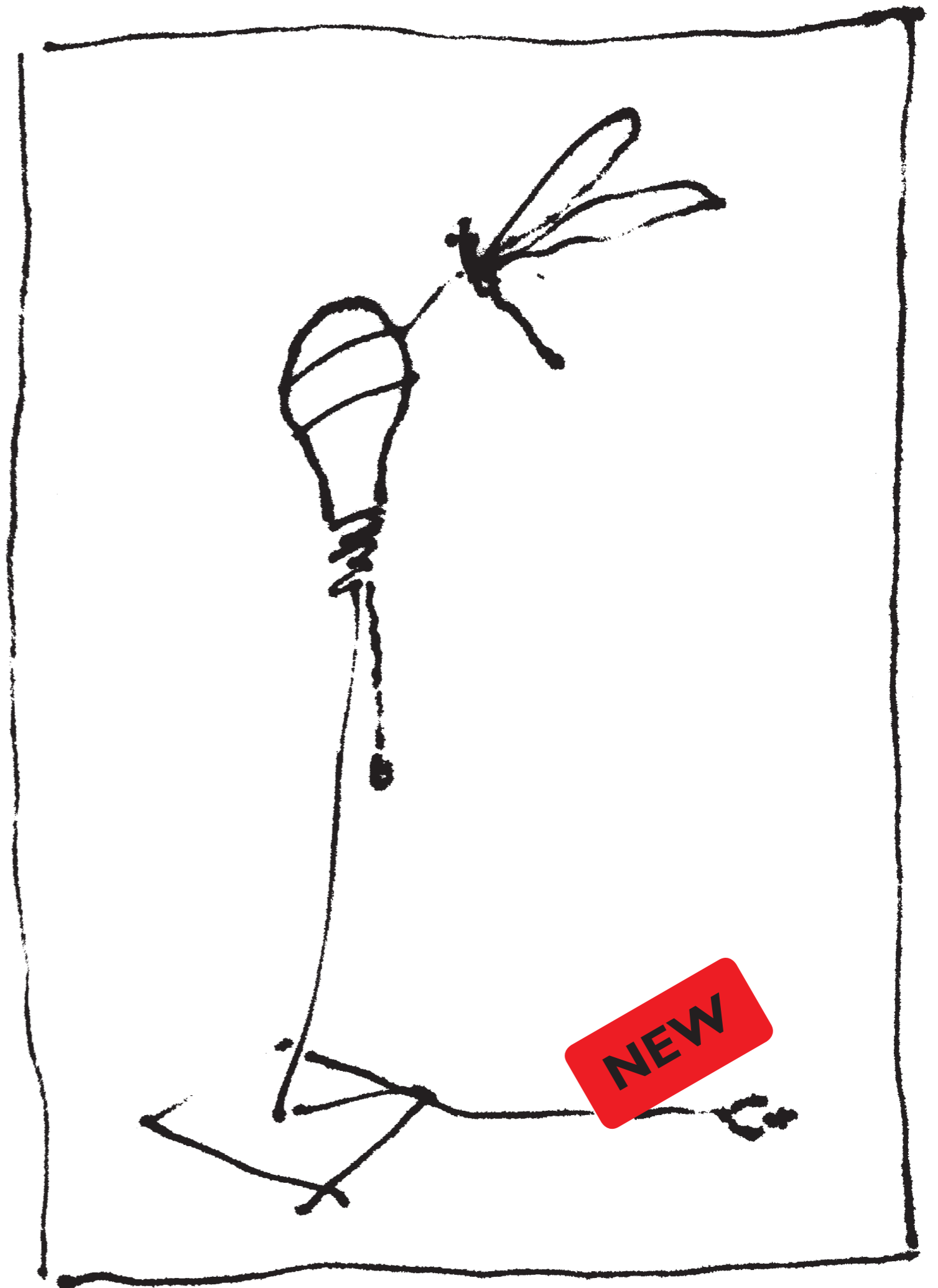

Coming soon: a new collection "*I Poveri Ricchi*"



← Product: ManOMan ↗

Sometimes, we organise exhibitions and lectures in our showroom. In February 2012, Deyan Sudjic and Moritz Waldemeyer visited us. Magis helped us out with the chairs.

„ ... endlich ein Ort, der das Herz erfreut und der mit Sicherheit zum Treffpunkt der unruhigen Geister aus aller Welt werden wird ... und das in München, man glaubt es kaum.“



Making Light Kaiserstrasse 47 München. Our studioshowroomwerkstattatelier **+shop** since 2008. Crossroads of restless spirits in Munich.

Styrofoam world



We think our showroom needs continuous change and a unique setting for our products. In summer 2011, Hagen Sczech, Sebastian Utermöhlen and other team members set up a styrofoam workshop to create a surreal living room landscape. For hours and hours of meticulous work, they cut and sanded furniture and details like spaghetti, Japanese cooking knives and a camera. We presented the finished work on September 15, 2011, at the party to celebrate the Compasso d'Oro Ingo Maurer received in 2011 for his body of work. As with most of our products, it is the manual work that matters in making really exceptional pieces that work as lamps yet often have the appearance of sculptural work.

... sometimes ghosts visit us.





Making Light 89 Grand Street New York, NY. Our shop in SoHo since 1999.

Foto: Antoine Boutez, New York

NEW

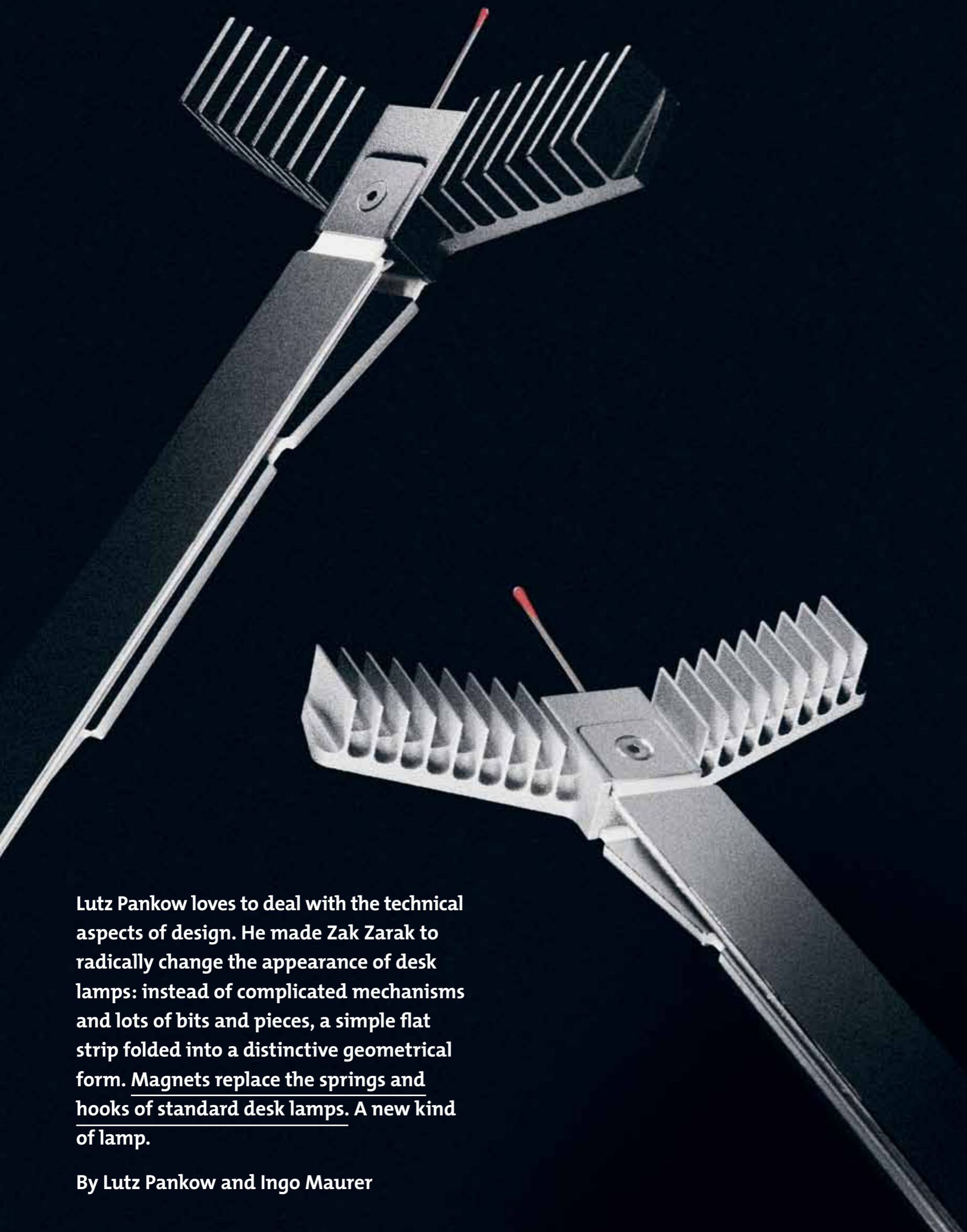

Lutz Pankow loves to deal with the technical aspects of design. He made Zak Zarak to radically change the appearance of desk lamps: instead of complicated mechanisms and lots of bits and pieces, a simple flat strip folded into a distinctive geometrical form. Magnets replace the springs and hooks of standard desk lamps. A new kind of lamp.

By Lutz Pankow and Ingo Maurer



ZAK ZARAK

Aluminium composite, metal, plastic. 2 warm white LEDs with 6.5 watts, 3000 K, 950 lm.
Length/height max. 80 cm. Rotates at the base 360°. Lamp head swivels through 30°.

NEW



ZAK ZARAK

Da + Dort

Here and There

Ici et Là

Qui e Lì

あちこち

Ahí y allá

Aqui e lá

Da + Dort

Here and There

Ici et Là

NEW

Da + Dort

The fantastic warm light of a paper shade, a lamp with countless positions. An ingenious mechanism. A juggler, a dancer that does what you want and need: perfect light. Based on aTool, 2003 by Christoph Matthias redesigned, 2012 by Ingo Maurer.



Design: Christoph Matthias and Ingo Maurer

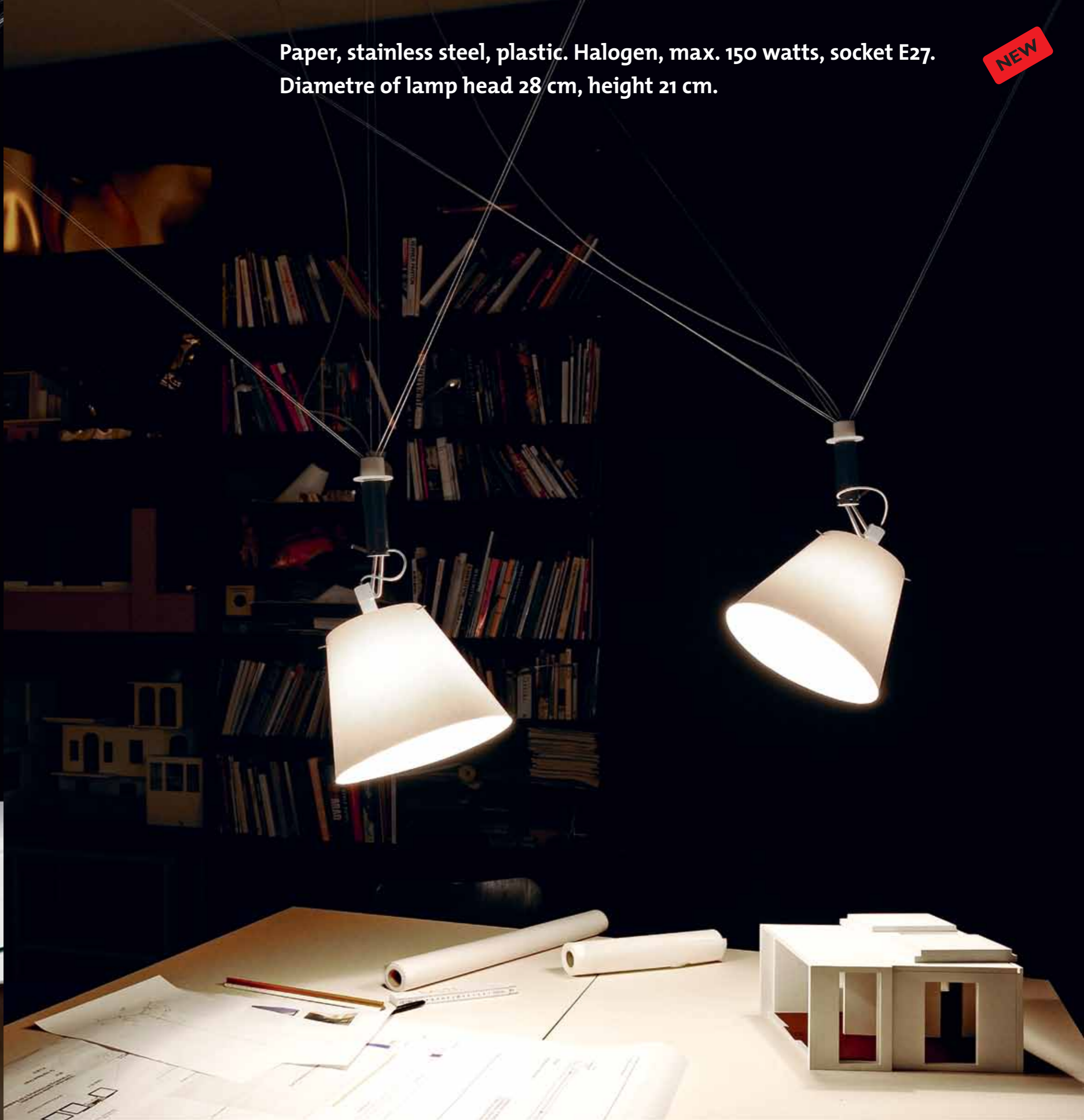

Paper, stainless steel, plastic. Halogen, max. 150 watts, socket E27.
Diametre of lamp head 28 cm, height 21 cm.

NEW

NEW



A brilliant idea by
Stefan Geisbauer
mimicking the
Luxo lamp. With
humour and wit
and an abundance
of light. Highly
functional. On the
way to becoming a
modern design icon.

Looksoflat available in black and silver.



Johnny B. Butterfly



J. B. Schmetterling

NEW

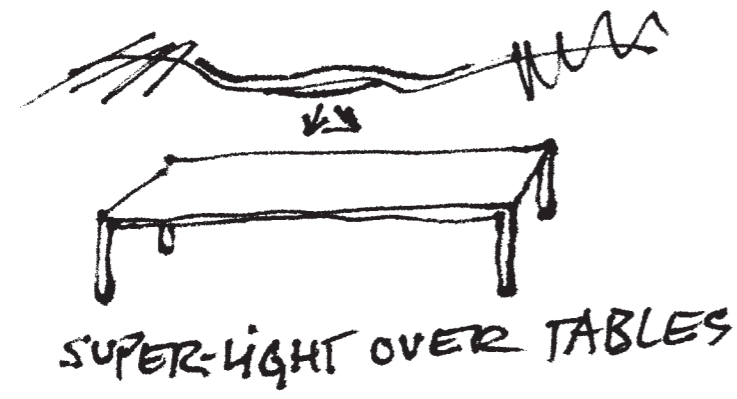

LUCE VOLANTE

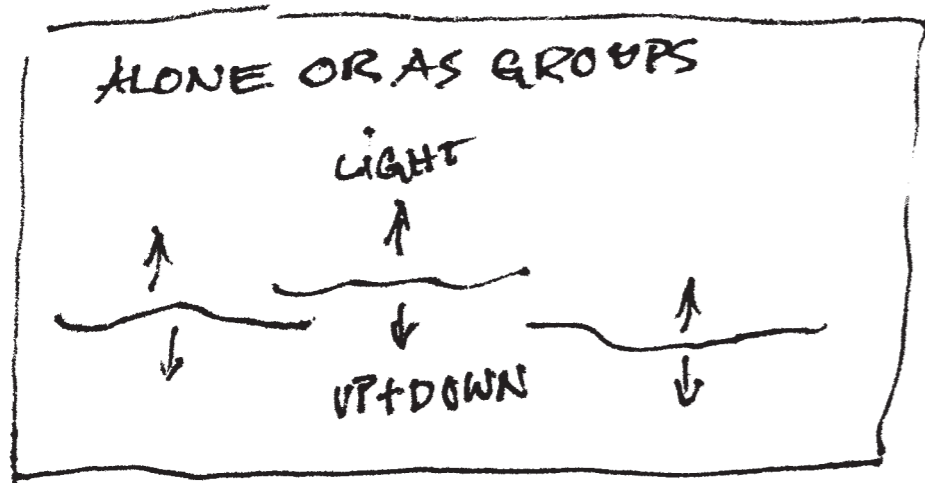
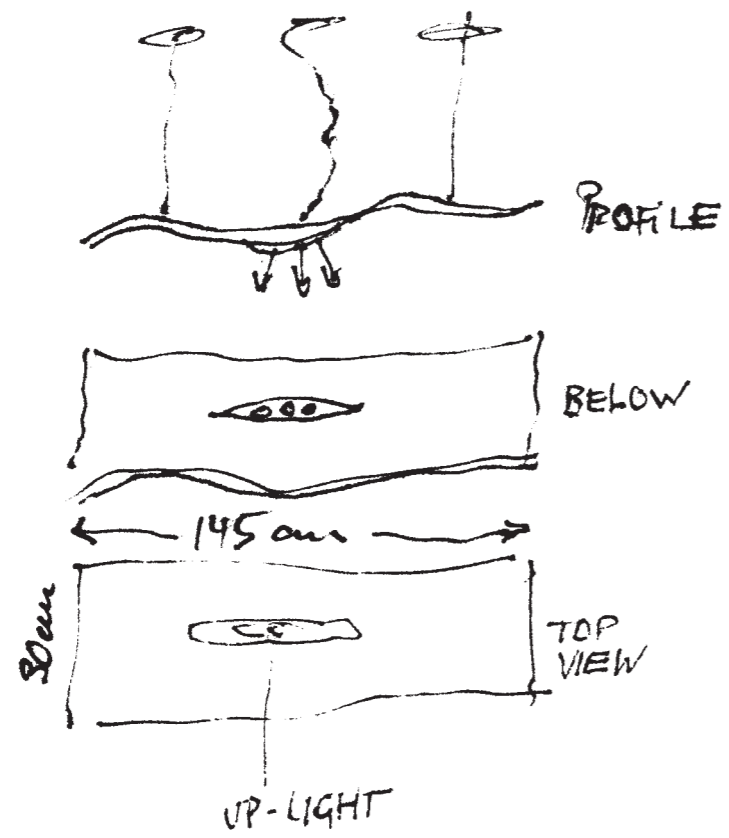

I.M.TEAM



Luce Volante

Fibreglass, metal, plastic. Downlight, three 10 watt LEDs. Uplight, one 10 watt LED, for a total of 4000 lm, 2700 K. 145 cm x 30 cm. Suspended on three wires, angle adjustable.

NEW

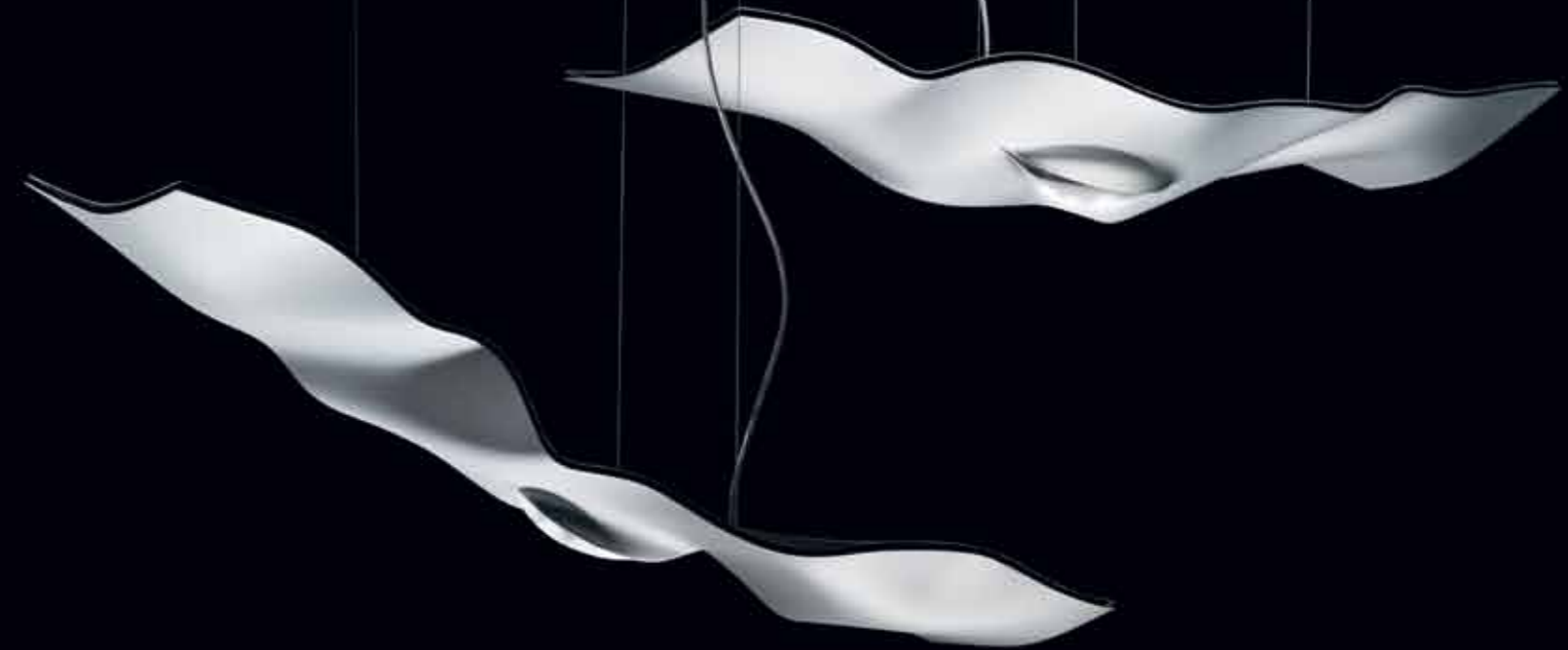

Luce Volante

NEW



YaYaHo Element 14



Since 1984, one of our most popular products, still widely in use.
Now available: two new fresh elements in white silicone.

YaYaHo Element 16

NEW



Aluminium, metal.
One 5 watt LED, 430 lumen.
With 12 volt transformer.

Our popular shelf light *Oskar* welcomes a LED sibling: meet the first prototype of *Ozzy Osled*. Thinking of generations to come.



The development of OLED technology is an ongoing process. In 2006, we presented two experimental objects. This is Double C. Future, created in 2010 with Orbeos OLED by Osram.



Prototype by Bernhard Dessecker, 2012.
The new Orbeos modules are twice as bright as two years ago.

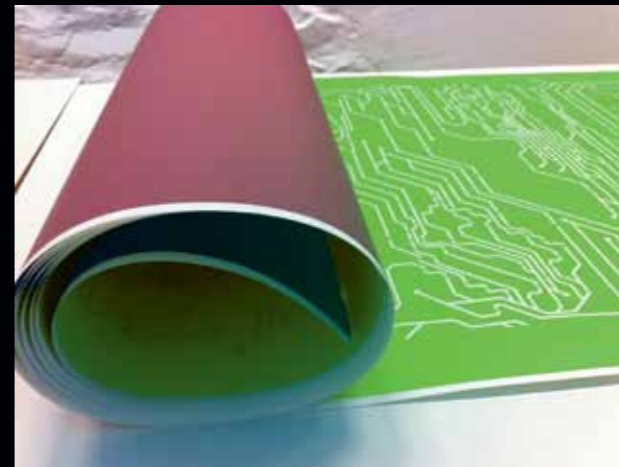

A long cherished dream has come true. The *LED Wallpaper* is now available in Red, Green, and White. Produced in Germany by Architects Paper.
www.architects-paper.com.



natural sponges

100 % handmade

waterproof

Objects of beauty and function collected in a sustainable way.

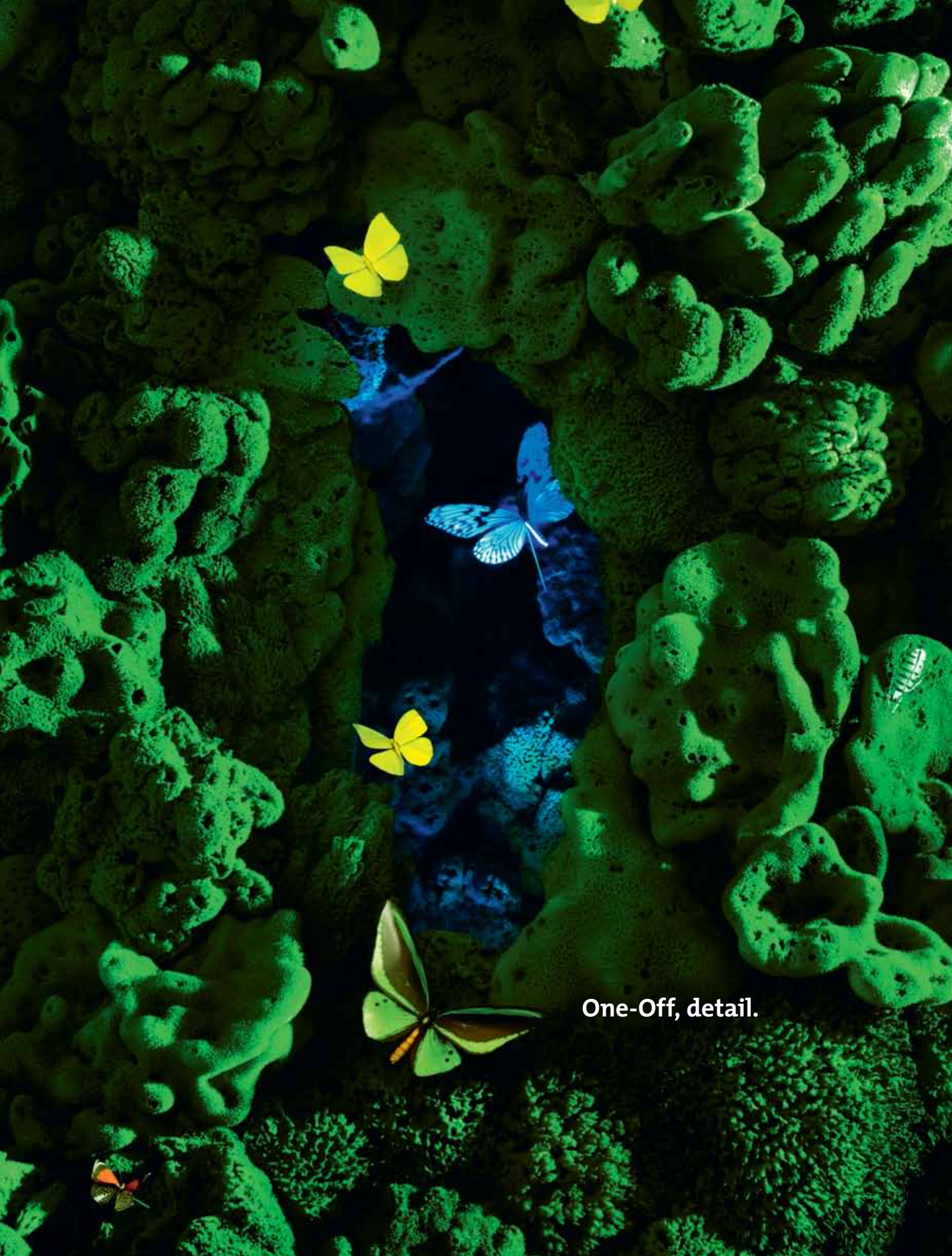

One-Off, detail.

“OH MAN, IT’S A RAY”
A modern chandelier.
Inspired by the artist
Man Ray. A perfect
solution for delicate
ceilings. Dimmable.
From soft to bright
light. Perfect for
restaurants, cafés
and private places.
This lamp is available
in various sizes and
made with the express
permission of the
Man Ray Trust.

© Man Ray Trust, Paris





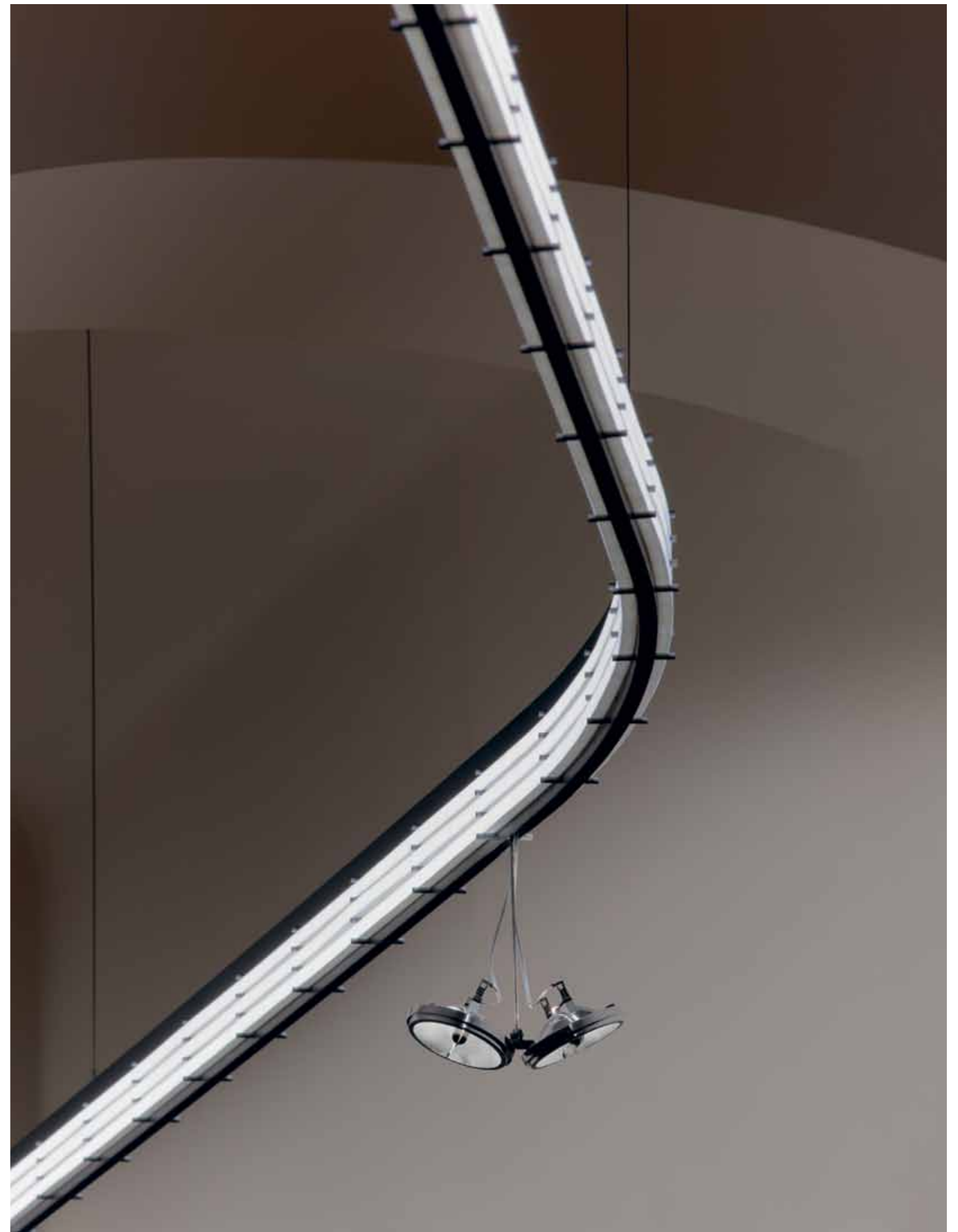

Custom-made office lighting.



Taking advantage
of the beauty of
technical elements.

Made to order.

Spirits Flying High One of a kind. From candlelight to ultra-bright.

Spirits Flying High Sophisticated LED technology.



Schlitz Up, our standard spectacular downlight. In different dimensions.



**ablaze – an installation
by Ingo Maurer and
Axel Schmid for Interni's
Mutant Architecture
exhibition at Cortile della
Farmacia, Milano 2011,
sponsored by ENEL.**





Comic Explosion – a unique piece,
at La Mania, Warsaw.



Golden Ribbon
Custom-made
sculptural object.
Manufactured
by us for a
private lighting
project.



XXL Dome Motel One, Berlin.

© Motel One

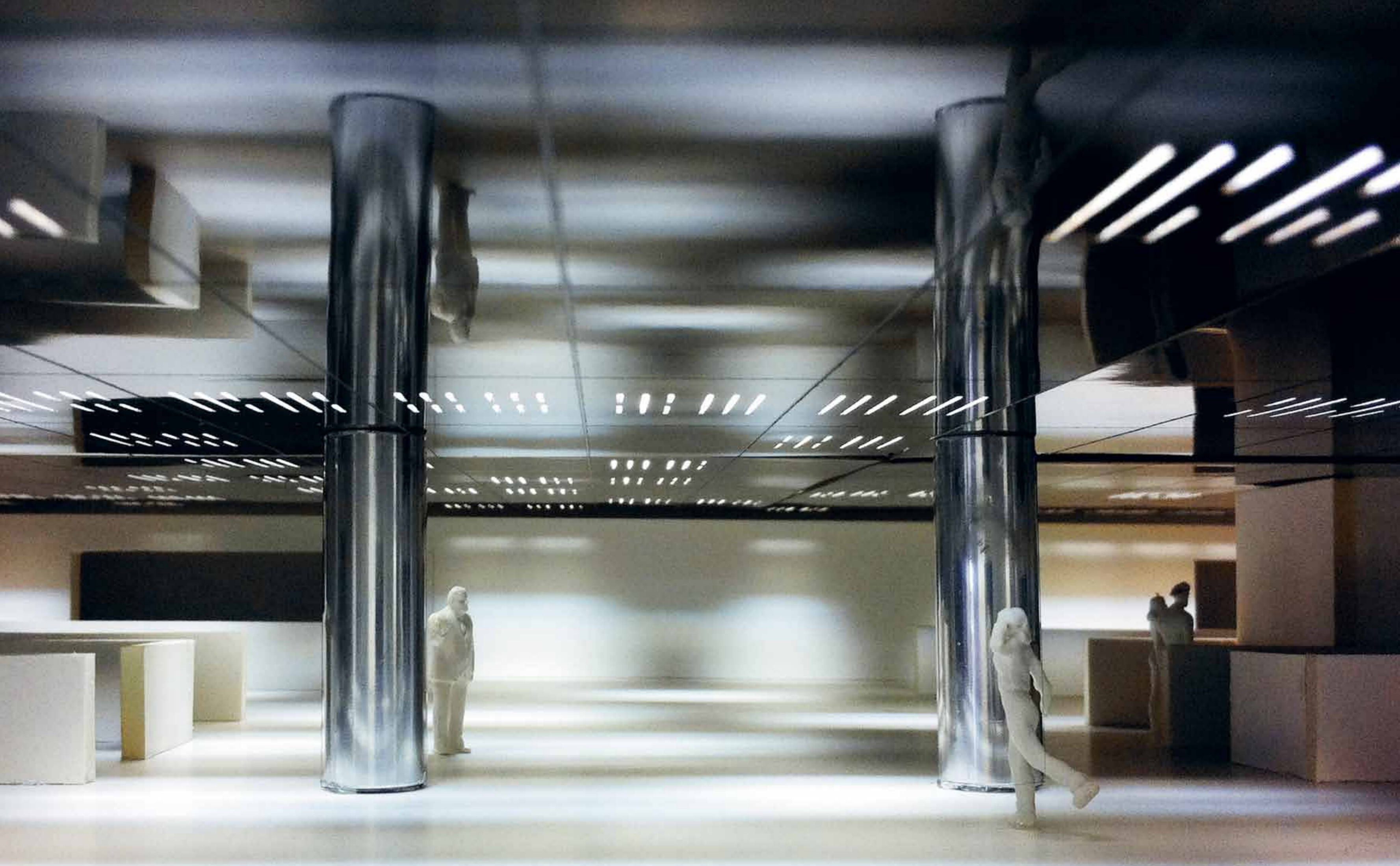

Study for an underground station.

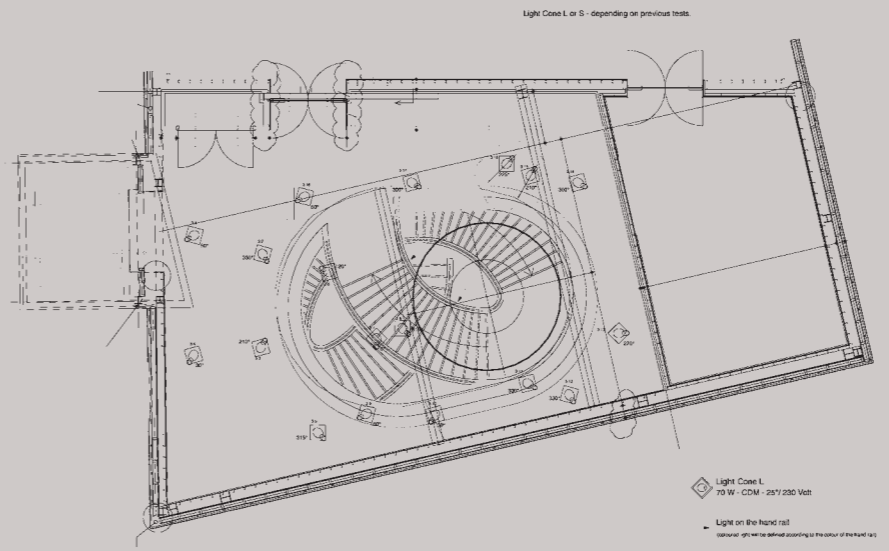

Light Cones
3rd Floor

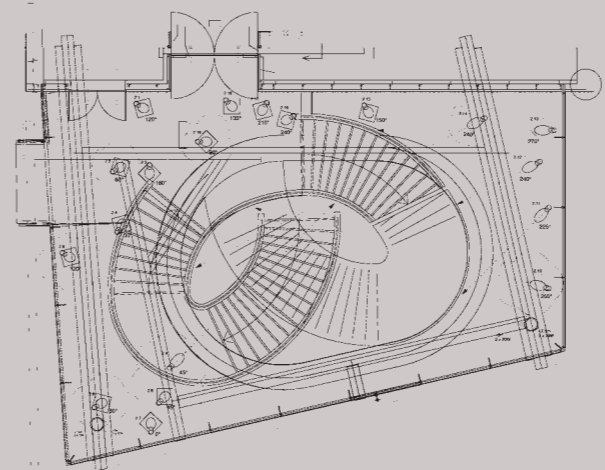

Light Cones
2nd Floor

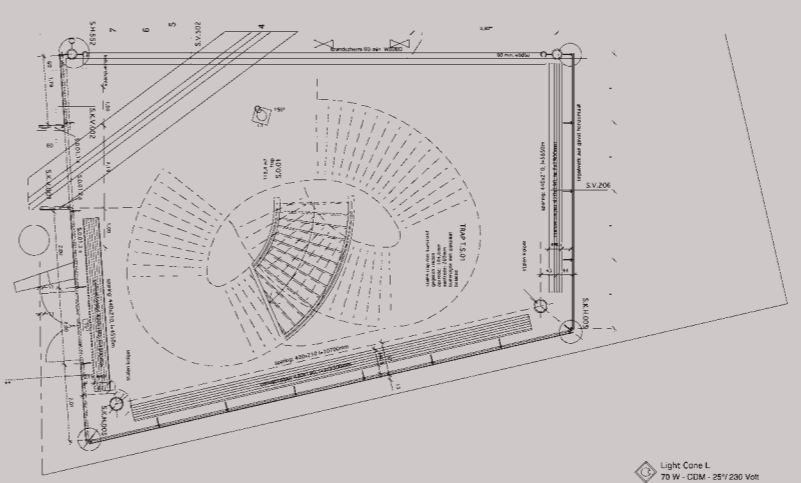

Light Cones
1st Floor

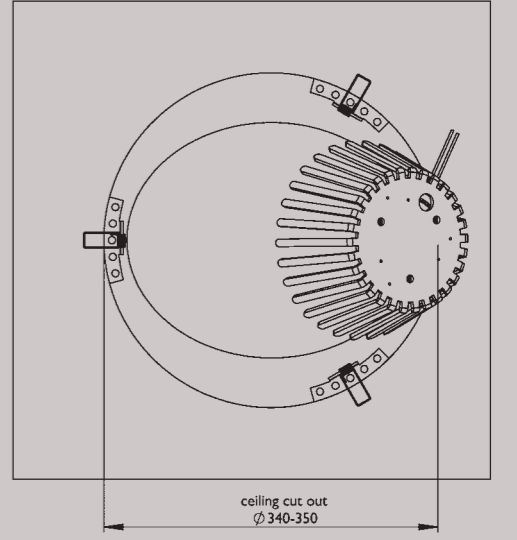
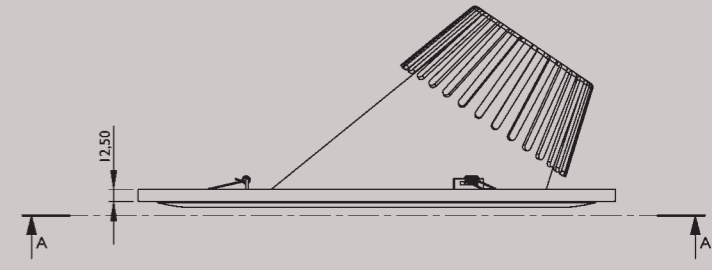

NEW

The seamless, built-in system *Light Cone* is now also available in an LED version. Used for lighting the entrance hall of the Stedelijk Museum s'Hertogenbosch, reopening planned for December 2012.



Foto: Robert Fischer, München



Foto: Robert Fischer, München

Part of our production hall in Munich.

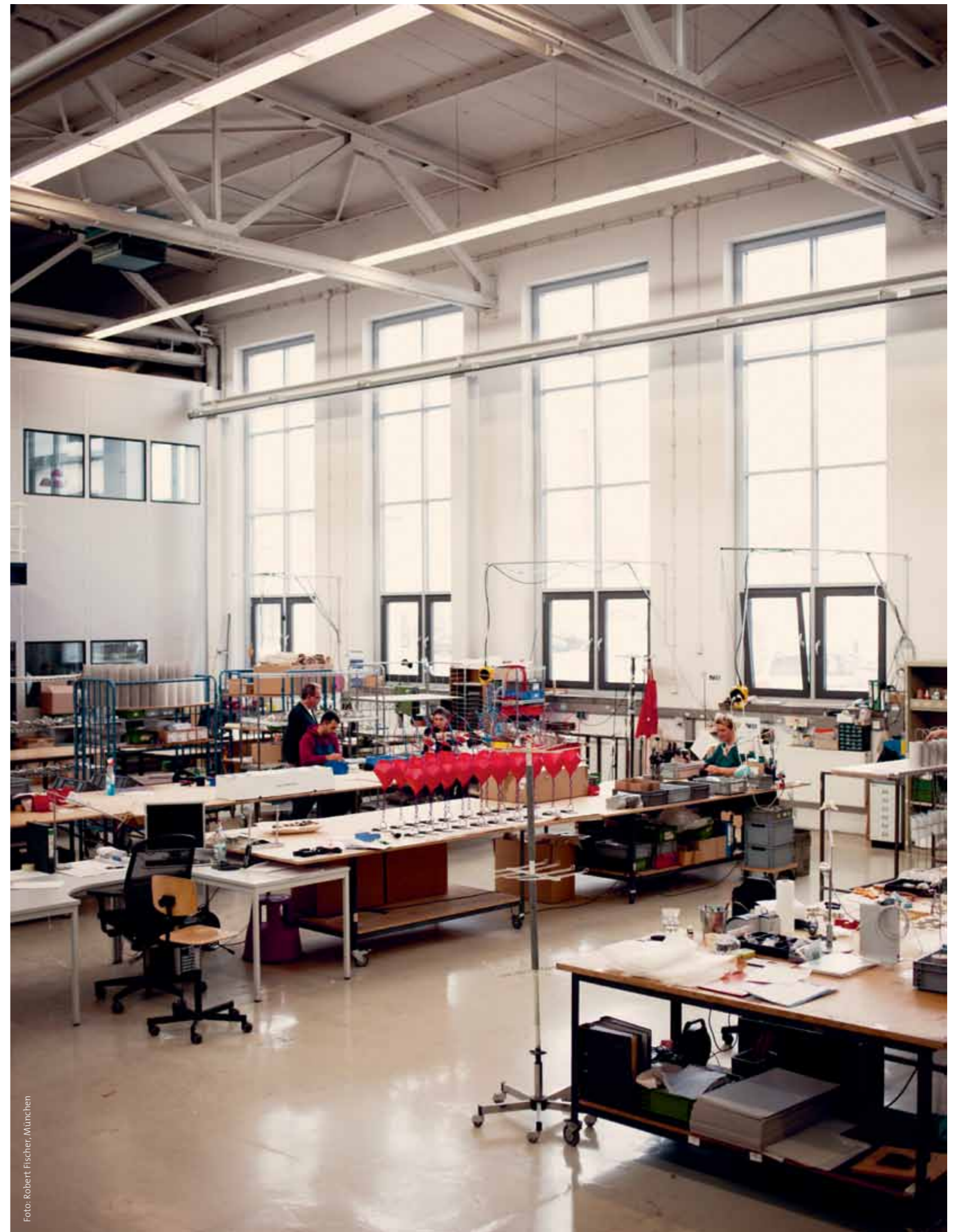

Fotografie:
Tom Vack, Milano/München

Grafik Design/Realisierung:
Frank Koschembar | gute-kommunikation.com

Koordination:
Claude Maurer, Hagen Szech, Peter Wachowich

Druck:
Graphicom, Vicenza

Bildbearbeitung/Compositing:
Stefan Geisbauer, red-light-design.com

Lithografie:
Oestreicher + Wagner Medientechnik, München

Ingo Maurer GmbH
Kaiserstrasse 47
80801 München
Tel. +49 89 381606-0
Fax +49 89 381606-20
info@ingo-maurer.com

Ingo Maurer LLC
89 Grand Street
New York, NY 10013
Tel. 212 965 8817
Fax 212 965 8819
making-light@ingomaurer-usa.com



Foto: Robert Fischer, München