

WHO HUREZ

We believe in the spirit of light.

Ingo Maurer GmbH
Kaiserstrasse 47
80801 München
Tel. +49 89 381 6060
Fax +49 89 381 606 20
info@ingo-maurer.com

Ingo Maurer LLC
89 Grand Street
New York, NY 10013
Tel. 212 965 8817
Fax 212 965 8819
making-light@ingomaurer-usa.com
www.ingo-maurer.com

Für's Licht und
74 Menschen,
meinem Team,
gewidmet.

I. M.

Dedicated
to light and
74 human beings,
my team.

I. M.



Destination Munich – Kaiserstrasse 47

Peter Groom

In December 2008, a new space opened in Munich – the showroom of world-renowned lighting designer, Ingo Maurer, where for the first time in Europe **“studioshowroomwerkstattatelier”** makes discovering Ingo Maurer prototypes, One-Offs, and entire lighting collection possible at one unique address. Situated just off a central courtyard marked by a giant 4.5 m high Water Column, you will find a secret garden where the entrance to the showroom awaits, and the glass doors part to welcome you to experience more than 130 products. Such a significant body of work in this well thought out setting creates a truly special experience for everyone.

The showroom is open to the public year round at Kaiserstrasse 47 in Munich. It is a place that allows for productive contemplation,





open dialogue, discussions, as well as technical explanations, but principally makes it possible to purchase lamps from the wide range of products on display. "This is a place to come where you can set your imagination free," says Ingo Maurer, "each experience is intended to be unique and we look forward to making this a reality for each and every visitor."

On first impression, the impact of the creative energy in the product is immediate and each light is placed in a way to allow you to indulge



your curiosity and learn more about this poet and magician of light. It is also a setting to obtain a deeper understanding about the High-Tech and “Manufaktur” aspects of Ingo Maurer products, along with an opportunity to take advantage of expert client services, schedule an appointment to discuss custom orders, obtain in-depth product knowledge or advice on project planning.

“To communicate the aesthetic and functional potential of a lamp, it’s best to have it where we have control of the environment it is in.



The customer can see both the lamp and the light it creates, as well as try out how it works," Ingo Maurer explains. "We have learned this consistently from the tradeshows, fairs and at our showroom in New York. We are looking forward to transferring this knowledge into the experience at Kaiserstrasse."



The effort to transfer a broader understanding of the product is present in every detail put into the showroom and as Ingo Maurer further articulates, "My wish for the new space on Kaiserstrasse is that it will allow the visitor to recognize our enthusiasm for the unique value of original lighting and inspire them to see more than just a lighting fixture. Our passion to create is very strong, and to



share this openly was the principal motivation for us to open this space.” Well worth a special trip to Munich, the opportunity to explore over 40 years of Ingo Maurer product design, both past and present, makes this most certainly a “not to be missed” design destination.

studioshowroomwerkstattatelier+shop

Kaiserstrasse 47, 80801 Munich, Germany, Phone: +49 89 381 60 691,
Fax: +49 89 381 60 690, Email: space@ingo-maurer.com,
www.ingo-maurer.com







To the man who started it all,
Thomas Alva Edison





Our Shop in New York

“89 Grand Street has been our home since 1999. I have always felt welcomed with open arms. New York is a place of possibilities, free and open. It makes me happy that I am part of it.”

I.M.





Ingo Maurer LLC 89 Grand Street New York, NY 10013 Tel. 212 965 8817
Fax 212 965 8819 making-light@ingomaurer-usa.com www.ingo-maurer.com



... and we do projects.



Model for redesign of U-Bahnhof Münchner Freiheit, Munich, renovation completed late 2009.

Our presentation models are a mix of playful imagination and precise design. We create them carefully to define and convey our vision for your project.

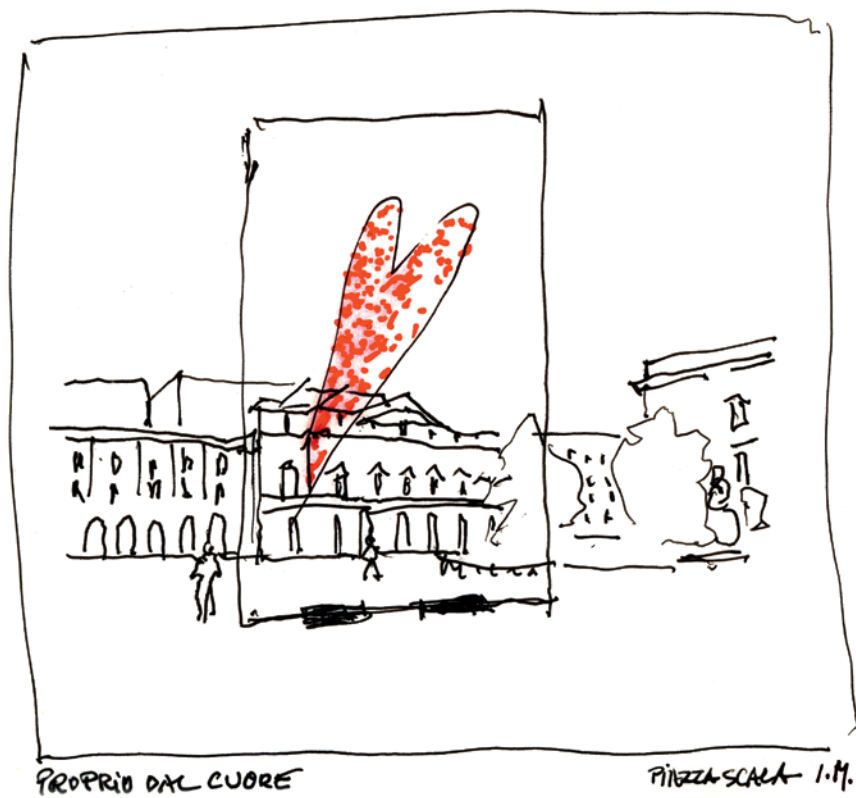


Our concept for Marienplatz subway station in Munich, created in partnership with Allmann Sattler Wappner Architects. Unanimously chosen as winner of the competition to redesign the mezzanine level in January 2011. Construction will begin early 2012.





Rendering for Machane Yehuda Market, Jerusalem (under construction)





Esch Belval, Luxembourg, 2008, ongoing



Prototypes for Atomium, Brussels, 2006

Everything was better in ancient times. Modern things are dangerous. That's why I go to work at my studio riding a horse.

When you shed a tear over the extinction of the incandescent bulb, many people think you are just being nostalgic. But for us it is something different: we mourn losing a component of our lighting toolbox. And it is an unequaled component of that toolbox.

Maybe the bulbs measurable characteristics do not meet requirements in a pragmatic perspective. But its distinct character can be sensed by ... well, maybe not by everyone, but at least by most of the people not working in the lamp-law producing office.

When I make lamps and lighting, I work like in a laboratory: my team and I develop things by building them in a most attentive and observing manner. That is why we developed a feeling for things you cannot quantify. A light fixture cannot be judged when it has been drawn, even though you already know its "lumen", "kelvin" and "ra", and its relation to the Planckian locus. It's the moment of switching it on, that tells you a lot about your design in an instant.

We are very happy about the discussion on how to save energy in lighting. This generated a lot of energy for inventions and innovations in lighting technology. Whenever a new technology appears, I am there to try it out. Our lighting toolbox is huge and filled with high-tech as well as low-tech, with ordinary and exotic things, with useful and useless techniques, with lighting punch and gentle shimmer, with Aah and Argh ...

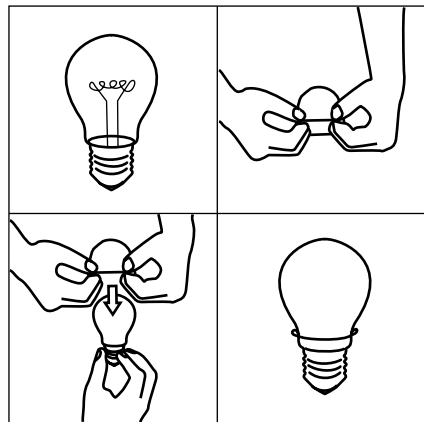
This helps me to find the perfect light for any lamp, for any room, for any situation. Can you understand why we are so upset that the amazing incandescent bulb is taken away from us? The bulb and its light has been a special piece in our toolbox - its light has a very special quality, its shape is simple yet most beautiful.

I don't want to talk about how difficult it is to recycle a compact fluorescent lamp anymore. Nor about how many hours a day you use the lamp above your dining table, how little energy is used for lighting when compared to other electrical appliances at home, nor about colour spectrums of different kind of light sources and the colours we see and the feelings we experience in a certain kind of light.

We just want to name and shame the extinction of the incandescent bulb, a little, harmless yet powerful widget that makes light in a way you can not simulate.

I. M.

First published in DAMN°26, October 2010



Lightbulbs only, max. 60 W. Do not use for sex.
Idea: Reinhold Brandmair, Ingo Maurer and Team.

How to protect yourself from stupid **Rules** – the **Euro Condom**



Hängelampen / Hanging lamps / Suspensions /
Lampade a sospensione / Lámparas de suspensión

- 34** Zufall
- 35** Silly-Kon
- 36** Johnny B. Butterfly
- 37** J. B. Schmetterling
- 38** Lunatic
- 40** Alizz C. Cooper
- 42** Metall C. Cooper
- 44** Eddie's Son
- 45** Wo bist du, Edison, ...?
- 48** OH MAN, IT'S A RAY!
- 50** ManOMan
- 52** Lacrime del Pescatore
- 54** Birds Birds Birds
- 55** Birdie
- 58** Pierre ou Paul
- 59** XXL Dome
- 62** Oh Mei Ma
- 64** Oh Mei Ma Kabir
- 64** Oh Mei Ma Kabir Weiss
- 65** Oh Mei Ma Weiss
- 66** YUU 200
- 67** Wafer
- 70** Bang Boom Zettel'z
- 72** Zettel'z 6
- 72** Zettel'z 5
- 74** 24 Karat Blau
- 75** 24 Karat Blau M
- 78** Hot Achille
- 80** Schlitz
- 82** Canned Light
- 84** Campari Light
- 86** Lucetto
- 87** Johnny B. Good
- 88** Manifold
- 90** Max. Up & Down
- 91** Öff Öff
- 92** aTool
- 94** Max. Mover
- 96** Big Dish
- 97** Living Vegas
- 98** Kabokov
- 99** Savoie
- 100** Five Pack
- 102** Fly Candle Fly!
- 104** Porca Miseria!
- 106** Tu-Be I
- 107** Tu-Be Lüster
- 108** Knitterling
- 109** Maru
- 110** Floatation
- 115** Willydilly
- 116** Grasl
- 117** Grasl Vulgaris



Tischlampen / Table lamps / Lampes de table /
Lampade da tavolo / Lámparas de sobremesa

- 120** Bulb
- 122** Looksoflat
- 124** Lucellino
- 126** Birdie's Busch
- 128** Alizz T. Cooper
- 129** Metall T. Cooper
- 130** Zufall
- 132** Jetzt
- 134** Tu-Be Two
- 136** Max.Kugler
- 138** Mozzkito
- 140** Prototype
- 142** Topolino
- 144** HOT.HOT
- 146** Delirium Yum
- 147** Lampampe
- 150** Bibibibi
- 151** Don Quixote
- 152** Grasl
- 152** Grasl Vulgaris
- 153** Los Minimalos Uno
- 154** Little Big Lamp
- 155** One From The Heart
- 156** Kuddelmuddel
- 157** Oskar
- 158** 24 Karat Blau T
- 159** Seven Rats



Stehlampen / Floor lamps / Lampadaires /
Lampade a stelo / Lámparas de pie

- 162** Ilios
- 164** aR-ingo
- 166** Metall F. Cooper
- 167** Alizz F. Cooper
- 170** Satel.light
- 172** Big Dish Floor
- 174** Radarr
- 178** Swingading
- 180** Prototype Floor
- 181** Knüller
- 182** Stand Up For Your Light



Deckenlampen / Ceiling lamps / Plafonniers /
Lampade da soffitto / Plafones

- 186** Birdie's Nest
- 188** Luxury Pure
- 189** Lil Luxury
- 192** Spock
- 193** Sista
- 194** Zuuk
- 195** Wandering Finger
- 198** Lampeduso
- 199** Tooling
- 200** Use Me C.
- 202** Light Cone
- 203** Schlitz Up



Wandlampen / Wall lamps / Appliques /
Lampade da parete / Apliques

- 212** Lucellino
- 213** Lucellino NT
- 214** Seven off the Wall
- 215** Twelve off the Wall
- 218** Holonzki
- 219** Dead Bulb Alive
- 220** Oskar
- 222** zero-one
- 223** Aka_Tsuki
- 224** Use Me W.
- 226** Santa Maria della Luce
- 228** Delight
- 230** Licht Licht
- 231** Los Minimalos Tres
- 234** Light au Lait
- 235** Canned Light
- 236** Bo-jek
- 237** Wandering Finger Wall
- 238** Max.Wall
- 239** Tooling
- 240** Max. Mover



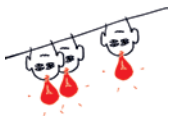
The MaMo Nouchies

- 247** Kokoro
- 248** Wo-Tum-Bu 1, 2, 3
- 251** Con-Qui
- 252** Jimken
- 253** Ysmen
- 254** Poul Poul
- 255** Samurai
- 256** Mahbruky
- 257** The Tribe: Aikaduli / Watapunga
- 258** Gaku



LED / OLED

- 265** Bellissima Brutta
- 266** Stardust
- 267** Licht.Enstein
- 268** LED Bench
- 270** LED Table
- 272** E.I.E.De
- 274** Lüster
- 276** One Thousand and One Lights
- 277** LED Paravent
- 278** Rose, Rose on the Wall ...
- 280** LED Wallpaper
- 282** New LED Products
- 284** Early Future
- 285** Flying Future
- 286** Double C. Future
- 288** Double T. Future
- 289** 4 x 4 is 34



Systeme / Systems
Système / Sistemi / Sistemas

- 292** YaYaHo
- 296** Element 14
- 298** Element 6 + 3
- 299** Element 1 + 77
- 300** Element 4 + 5
- 301** Element 2 + Spiegel/Mirror/Miroir/Specchio/Espejo
- 310** Hoi Polloi
- 312** BaKaRú

**Zeichenerklärung / Signs and symbols / Légende /
Simboli e descrizione / leyenda**



Leuchtmittel / Light source / Agent lumineux / Lampada /
Elemento luminoso



Mit elektronischem Transformator-Sensor-Dimmer *Touch Tronic* /
With *Touch Tronic* transformer-sensor-dimmer / Avec transformateur-
sensor-dimmer *Touch Tronic* / Con trasformatore-sensore-dimmer *Touch
Tronic* / Con transformador eletrónico Sensor-dimmer *Touch Tronic*



Mit elektronischem Transformator mit Schieberegler / With electronic
transformer with dimmer / Avec transformateur électronique à cur-
seur / Con trasformatore elettronico con varialuce lineare / Con trans-
formador electrónico / Con transformador electrónico con regulador
por corredera



Lieferbar mit *Touch Tronic* oder Transformator mit Schieberegler / Avail-
able with *Touch Tronic* or transformer with silde control / Disponible
avec *Touch Tronic* ou transformateur électronique à curseur / Disponi-
bile con *Touch Tronic* oppure trasformatore con varialuce lineare /
Disponibile con *Touch Tronic* o con transformador con regulador por
corredera



Mit integriertem Transformator / With built-in transformer / Con tras-
formatore integrato / Avec transformateur intégré / Con transformador
integrado



Kabellänge / Cable length / Longueur du câble / Lunghezza cavo /
Longitud de cable



Neues Produkt / New product / Nouveau produit / Nuovo prodotto /
Nuevo producto

Alle Maßangaben in Zentimeter / All dimensions in centimeters /
Toutes dimensions en centimètres / Tutte le misure in centimetri /
Todas las dimensiones en centímetros

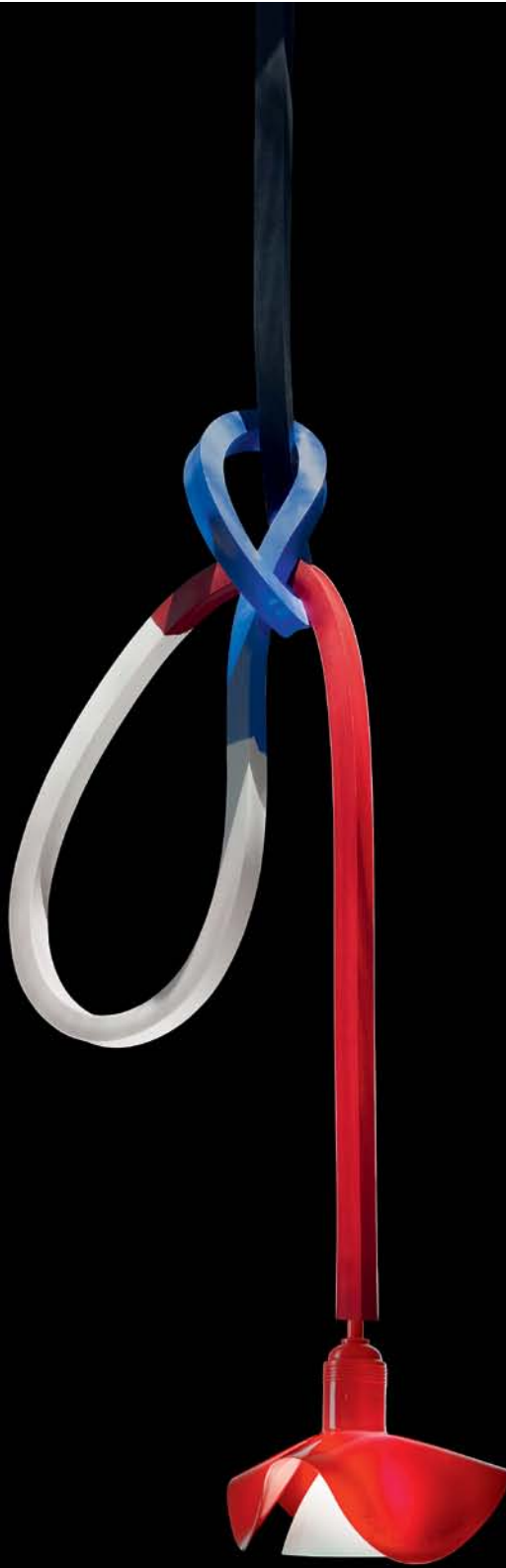






Designed by Ingo Maurer

max. 260



Zufall Ingo Maurer und Team 2008

Silikon, Metall. Der Silikonkörper kann flexibel verknotet werden. Für Raumhöhen bis 300 cm. Baldachin Ø 8 cm. Lieferung mit Leuchtmittel. ■ Silicone, metal. The silicone body is flexible. The knot can be flexibly adjusted. For ceiling heights up to 300 cm. Canopy Ø 8 cm. Complete with bulb. ■ Silicone, métal. Il est possible de faire des noeuds au tuyau flexible en silicone. Pour hauteurs de pièce jusqu'à 300 cm. Baldaquin Ø 8 cm. Livrée avec ampoule. ■ Silicone, metallo. Il corpo flessibile di silicone permette una regolazione variabile. Per soffitti con altezze fino cm. 300. Rosone Ø cm. 8. Lampadina inclusa. ■ Silicona, metal. El cuerpo de silicona puede anudarse flexiblemente. Para alturas hasta 300 cm. Florón Ø 8 cm. Suministrada con bombilla.



Silly-Kon Ingo Maurer und Team 2010

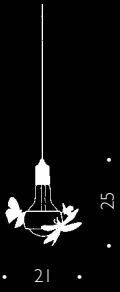
Silikon, Metall. Transparentes Kabel und Baldachin, Ø 8 cm. Lieferung mit Leuchtmittel.

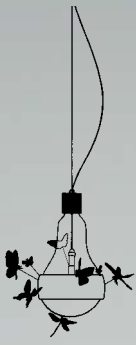
■ Silicone, metal. Transparent cable and canopy, Ø 8 cm. Complete with bulb. ■

Silicone, métal. Câble et baldaquin transparents, Ø 8 cm. Livrée avec ampoule. ■ Sili-

cone, metallo. Cavo e rosone trasparenti, Ø cm. 8. Lampadina inclusa. ■ Silicona, metal.

Cable y florón transparente, Ø 8 cm. Suministrada con bombilla.

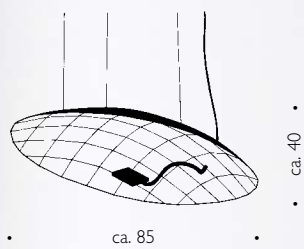




46

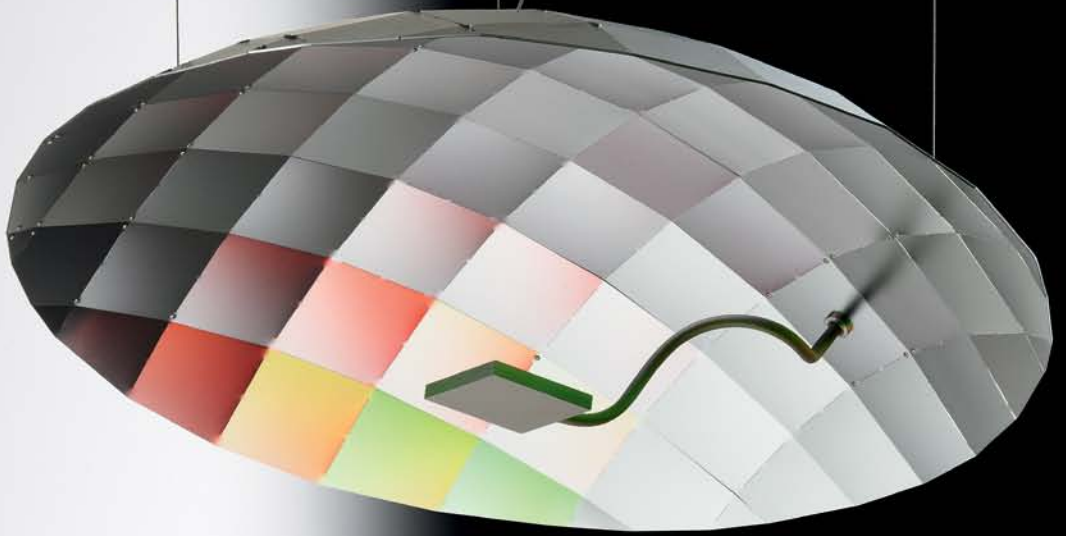
32

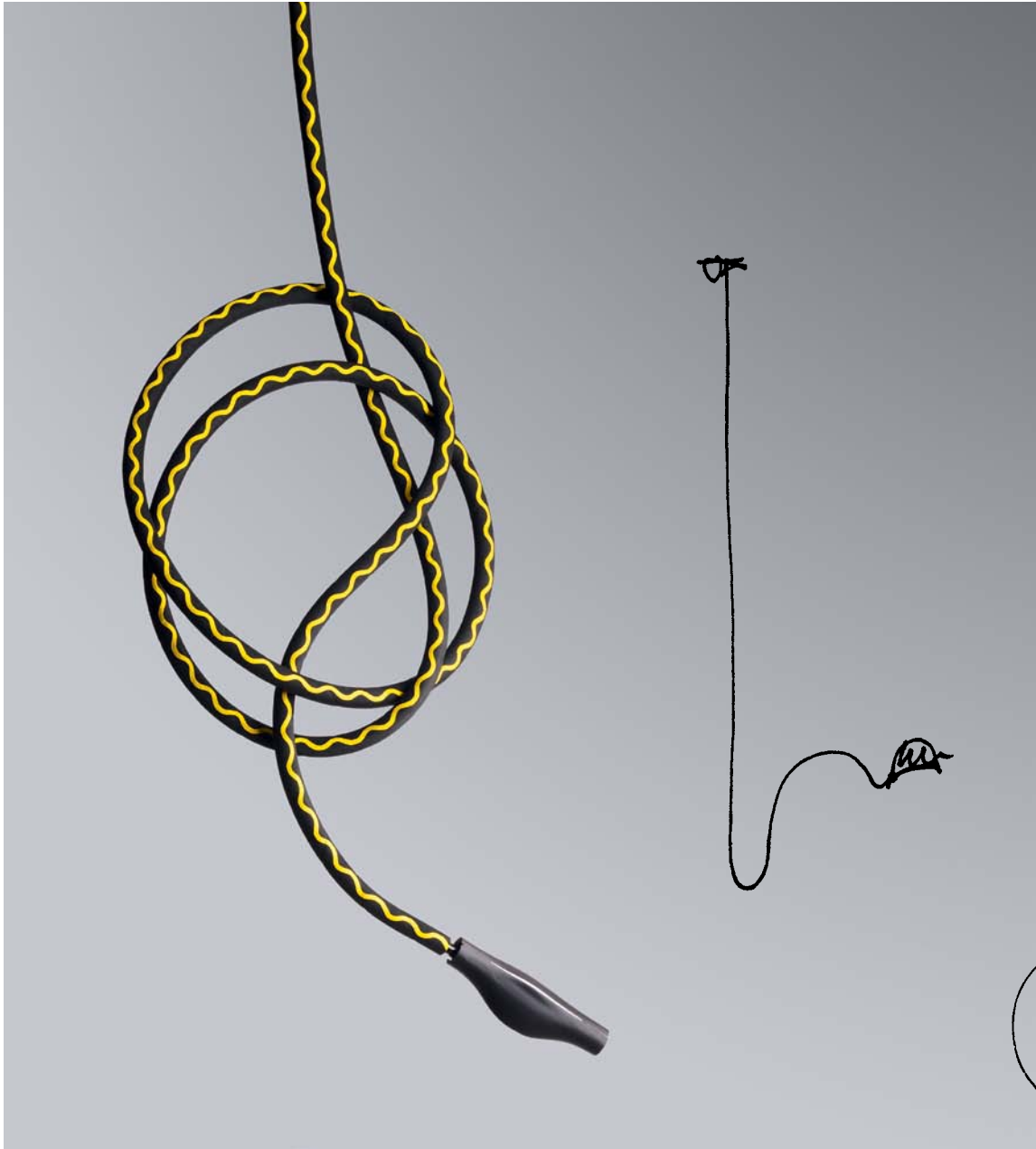




Lunatic Tobias Reischle, Ingo Maurer und Team 2011

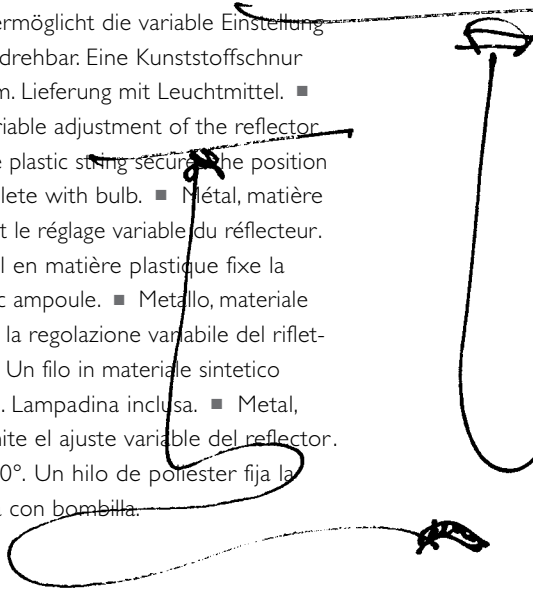
Aluminium, Metall. Mit elektronischem Vorschaltgerät. Lieferung mit Leuchtmittel. ■ Aluminium, metal. With electronic ballast. Complete with bulb. ■ Aluminium, métal. Avec ballast électronique. Livrée avec ampoule. ■ Alluminio, metallo. Con alimentatore elettronico. Lampadina inclusa. ■ Aluminio, metal. Con balastro electrónico. Suministrada con bombilla.

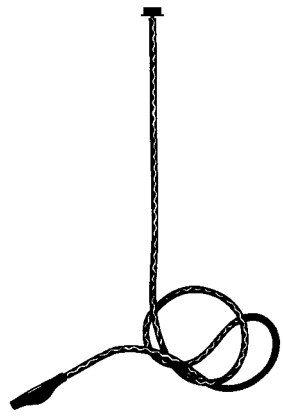
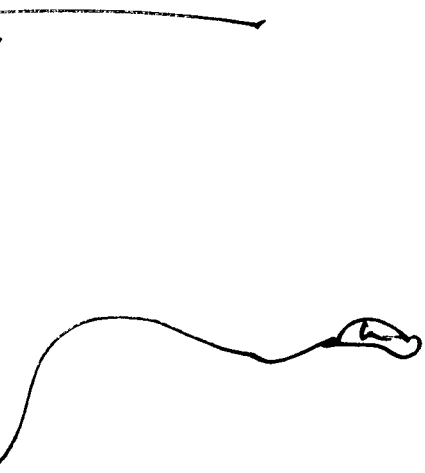
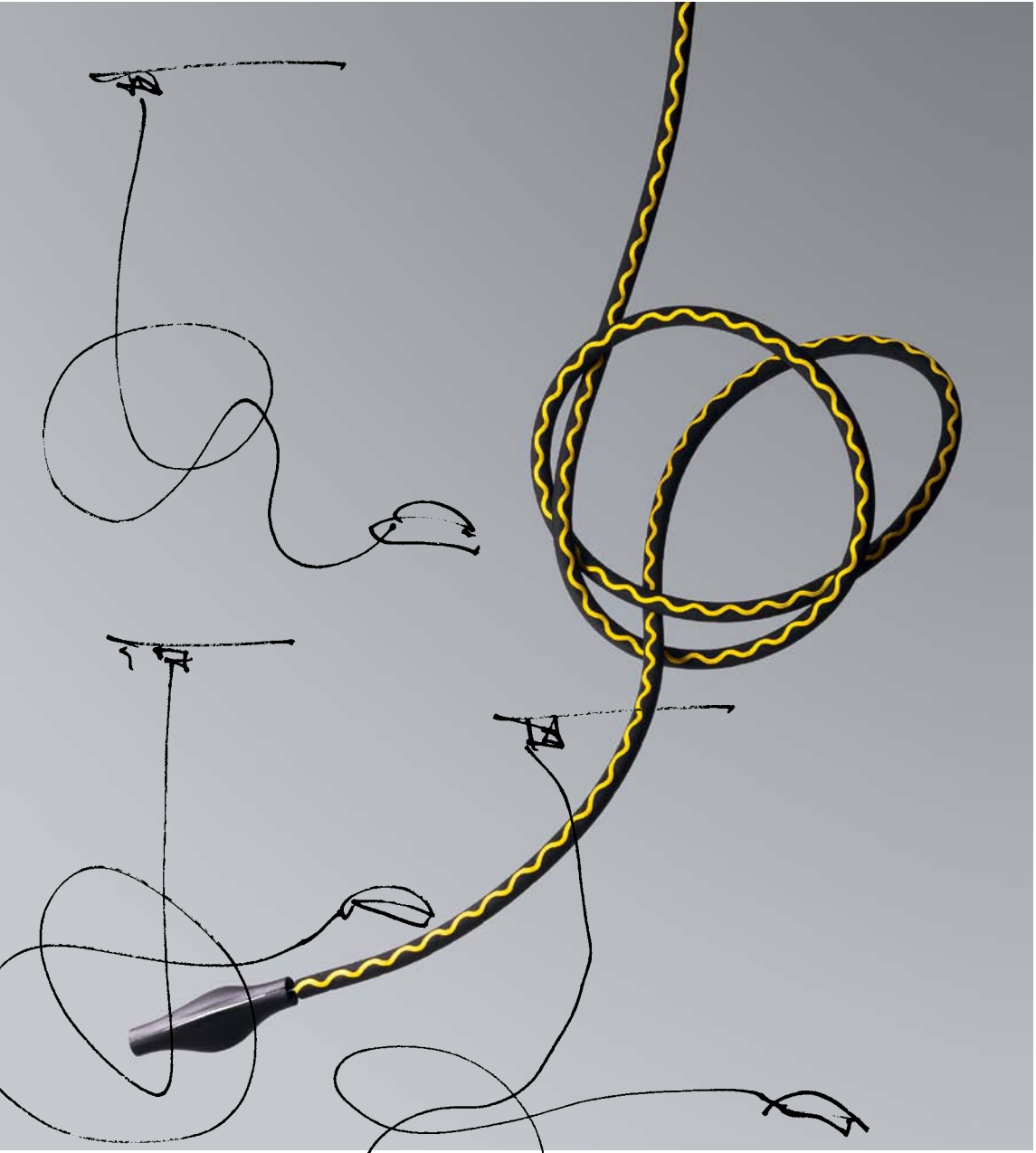




Alizz C. Cooper Ingo Maurer und Team 2008

Metall, Kunststoff, Gummischlauch. Der flexible Arm ermöglicht die variable Einstellung des Reflektors. Reflektor 360° um das Leuchtmittel drehbar. Eine Kunststoffschnur sichert die Position des Reflektors. Baldachin Ø 8,5 cm. Lieferung mit Leuchtmittel. ■ Metal, plastic, rubber hose. The flexible arm allows variable adjustment of the reflector. Reflector rotates through 360° around the bulb. A fine plastic string secures the position of the extended armature. Canopy Ø 8,5 cm. Complete with bulb. ■ Métal, matière plastique, tuyau en caoutchouc. Le bras flexible permet le réglage variable du réflecteur. Réflecteur rotatif de 360° autour de l'ampoule. Un fil en matière plastique fixe la position du réflecteur. Baldaquin Ø 8,5 cm. Livrée avec ampoule. ■ Metallo, materiale sintetico, tubo di gomma. Il braccio flessibile permette la regolazione variabile del riflettore. Riflettore rotante di 360° intorno alla lampadina. Un filo in materiale sintetico assicura la posizione del riflettore. Rosone Ø cm. 8,5. Lampadina inclusa. ■ Metal, plástico, manguera de caucho. El brazo flexible permite el ajuste variable del reflector. Reflector giratorio alrededor de la bombilla hasta 360°. Un hilo de poliéster fija la posición del reflector. Florón Ø 8,5 cm. Suministrada con bombilla.



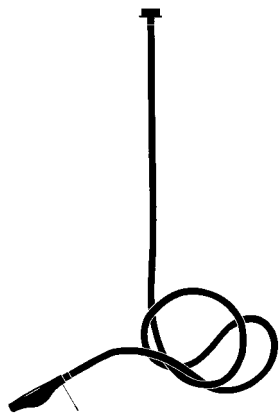


max. 320

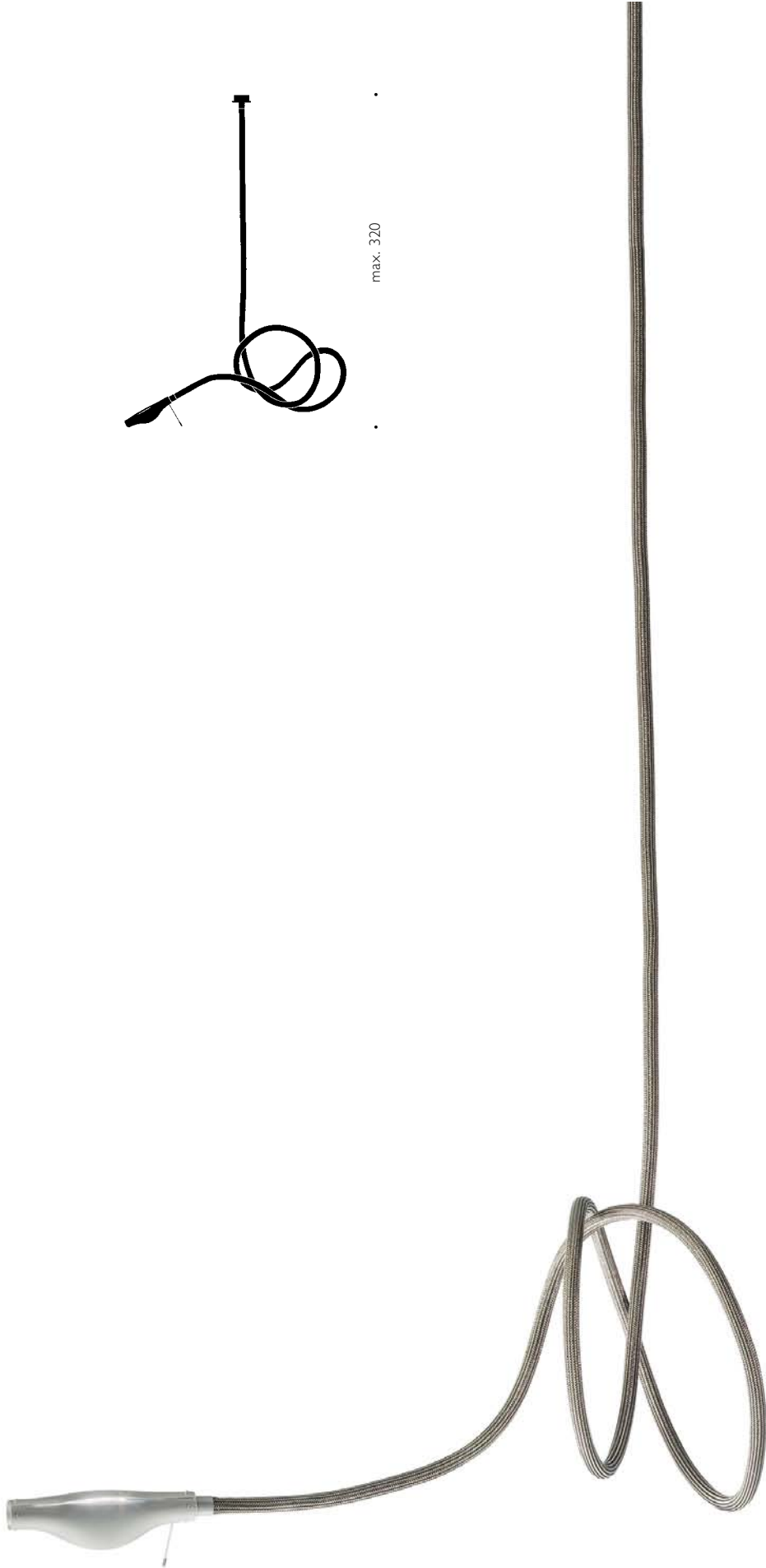


Metall C. Cooper Ingo Maurer und Team 2009

Metall, Kunststoff. Der flexible Arm ermöglicht die variable Einstellung des Reflektors. Reflektor 360° um das Leuchtmittel drehbar. Eine Kunststoffschnur sichert die Position des Reflektors. Baldachin Ø 8,5 cm. Lieferung mit Leuchtmittel. ■ Metal, plastic. The flexible arm allows variable adjustment of the reflector. Reflector rotates through 360° around the bulb. A fine plastic string secures the position of the extended armature. Canopy Ø 8,5 cm. Complete with bulb. ■ Métal, matière plastique. Le bras flexible permet le réglage variable du réflecteur. Réflecteur rotatif de 360° autour de l'ampoule. Un fil en matière plastique fixe la position du réflecteur. Baldaquin Ø 8,5 cm. Livrée avec ampoule. ■ Metallo, materiale sintetico. Il braccio flessibile permette la regolazione variabile del riflettore. Riflettore rotante di 360° intorno alla lampadina. Un filo in materiale sintetico assicura la posizione del riflettore. Rosone Ø cm. 8,5. Lampadina inclusa. ■ Metal, plástico. El brazo flexible permite el ajuste variable del reflector. Reflector giratorio alrededor de la bombilla hasta 360°. Un hilo de poliéster fija la posición del reflector. Florón Ø 8,5 cm. Suministrada con bombilla.



max. 320





Eddie's Son Ingo Maurer und Eckhard Knuth 2005

Kunststoff, Metall, Hologramm 360°. Transformator im Baldachin integriert. Lieferung mit Leuchtmittel. Eddie's Son kann nicht direkt auf den Deckenauslass montiert werden. ■ Plastic, metal, hologram 360°. Transformer integrated in canopy. Complete with bulb. It is not possible to mount the lamp directly on the ceiling outlet. ■ Matière plastique, métal, hologramme 360°. Transformateur intégré dans le baldaquin. Livrée avec ampoule. Eddie's Son ne peut être montée directement sur la sortie électrique du plafond. ■ Materiale sintetico, metallo, ologramma 360°. Trasformatore integrato nel rosone. Lampadina inclusa. Eddie's Son non può essere collegata direttamente all'uscita della corrente a soffitto. ■ Plástico, metal, holograma 360°. Transformador integrado en el florón. Suministrada con bombilla. Eddie's Son no puede ser montada directamente en la toma de corriente del techo.

Direkte Sonneneinstrahlung und Nikotin können die Lebensdauer der Hologramme reduzieren. ■ Direct sunlight and nicotine may reduce the life span of the holograms. ■ Une exposition directe au soleil et à la nicotine peut réduire la durée de vie des hologrammes. ■ L'esposizione diretta al sole e alla nicotina possono ridurre la durata degli ologrammi. ■ La exposición directa a la luz solar y a la nicotina pueden reducir la vida útil del hologramas.



Wo bist du, Edison, ...? Ingo Maurer 1997

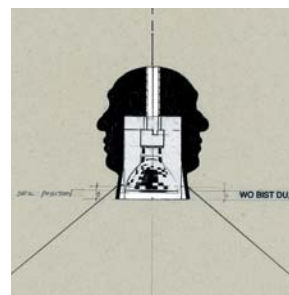
Acrylglas, Aluminium, Hologramm 360°. Transformator im Baldachin, Ø 13 cm, integriert. Lieferung mit Leuchtmittel. Kann nicht direkt auf den Deckenauslass montiert werden.

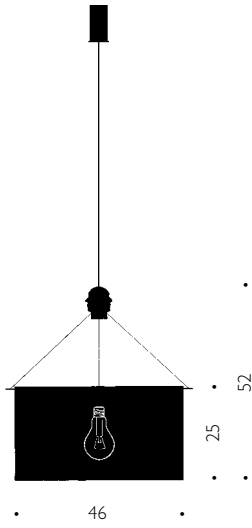
■ Acrylic glass, aluminium, hologram 360°. Transformer integrated in canopy, Ø 13 cm. Complete with bulb. It is not possible to mount the lamp directly on the ceiling outlet. ■

Verre acrylique, aluminium, hologramme 360°. Transformateur intégré dans le baldachin, Ø 13 cm. Livrée avec ampoule. Ne peut être montée directement sur la sortie électrique du plafond. ■

Vetro acrilico, alluminio, ologramma 360°. Trasformatore integrato nel rosone, Ø 13 cm. Lampadina inclusa. Non può essere collegata direttamente all'uscita della corrente a soffitto. ■

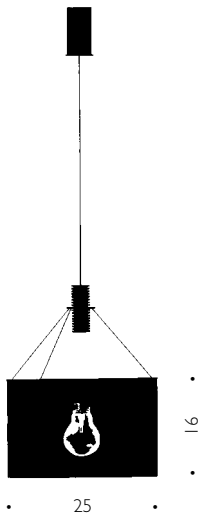
Cristal acrílico, aluminio, holograma 360°. Transformador integrado en el florón, Ø 13 cm. Suministrada con bombilla. No puede ser montada directamente en la toma de corriente del techo.





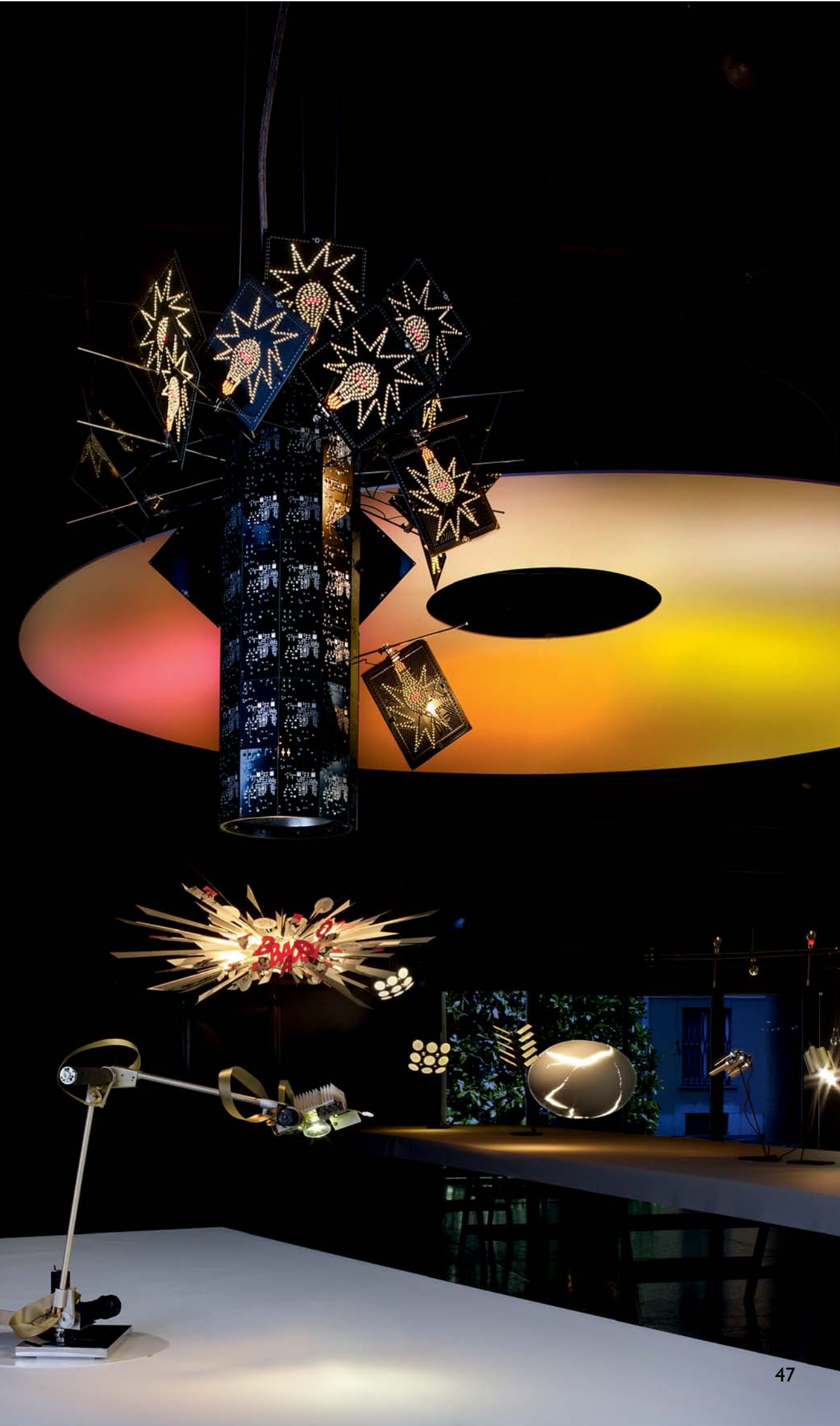
Wo bist du, Edison, ...?

max. 50 W Halogen GX 5,3 transformer 12 V
 cable 200 cm



Eddie's Son

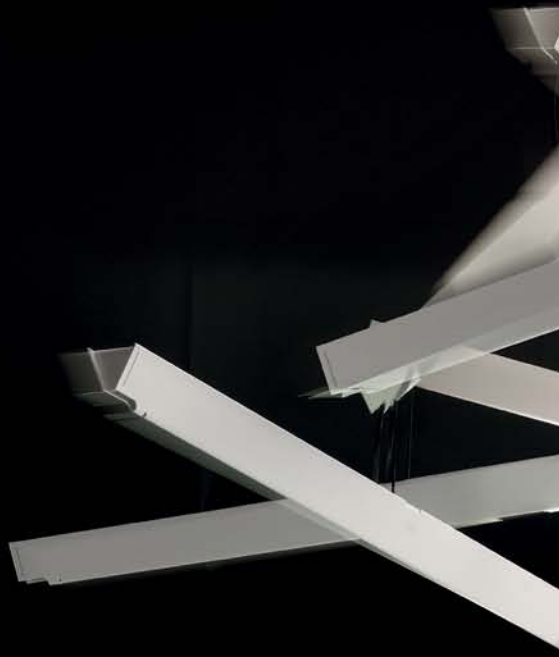
max. 50 W Halogen GY6,35 transformer 12 V
 cable 300 cm

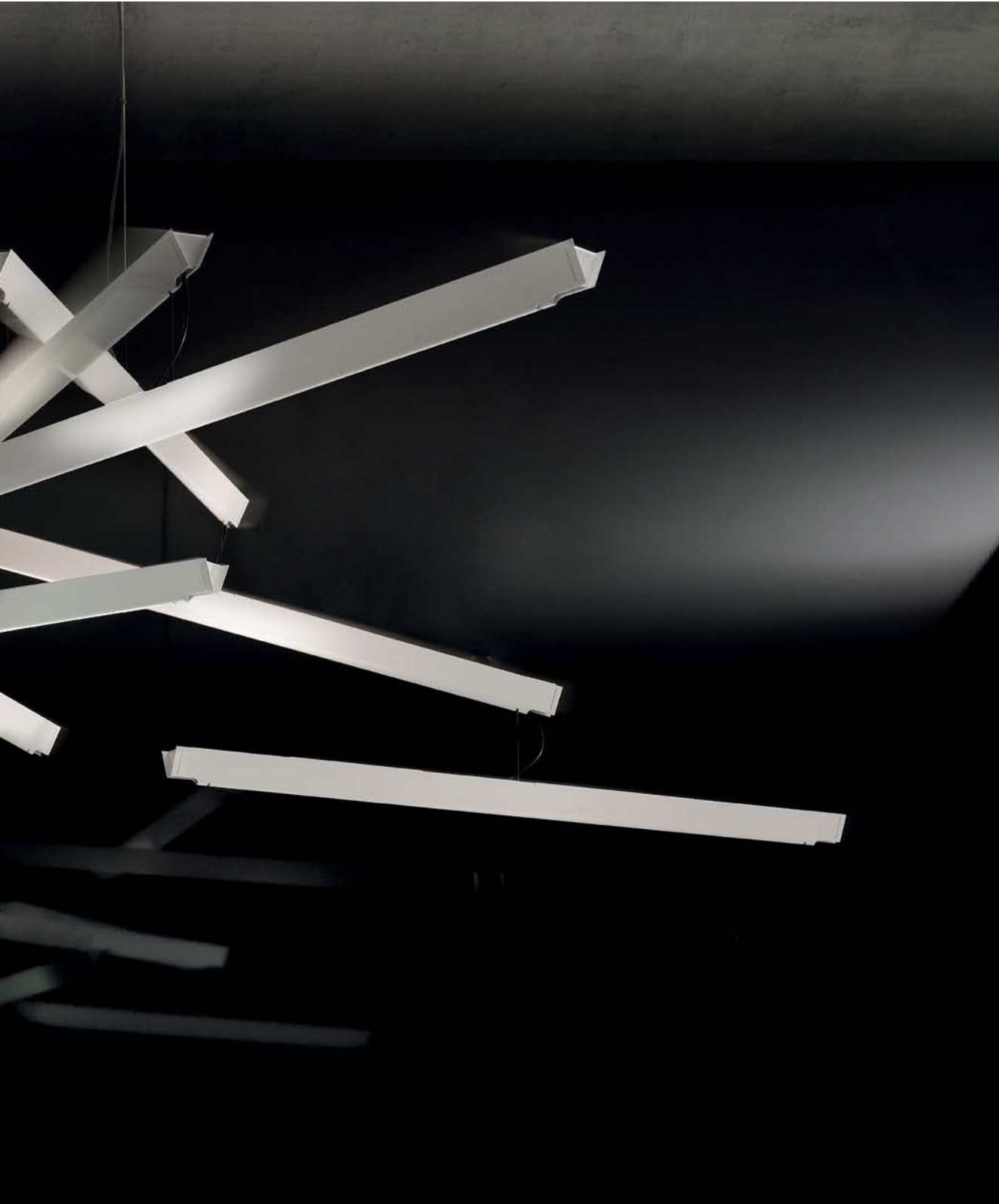






OH MAN, IT'S A RAY! uses incandescent low voltage 24 V, 15 W bulbs.
Design by Ingo Maurer und Team. Ingo Maurer was inspired by the work
of the artist Man Ray. This lamp is available in various sizes and made with
the express permission of the Man Ray Trust





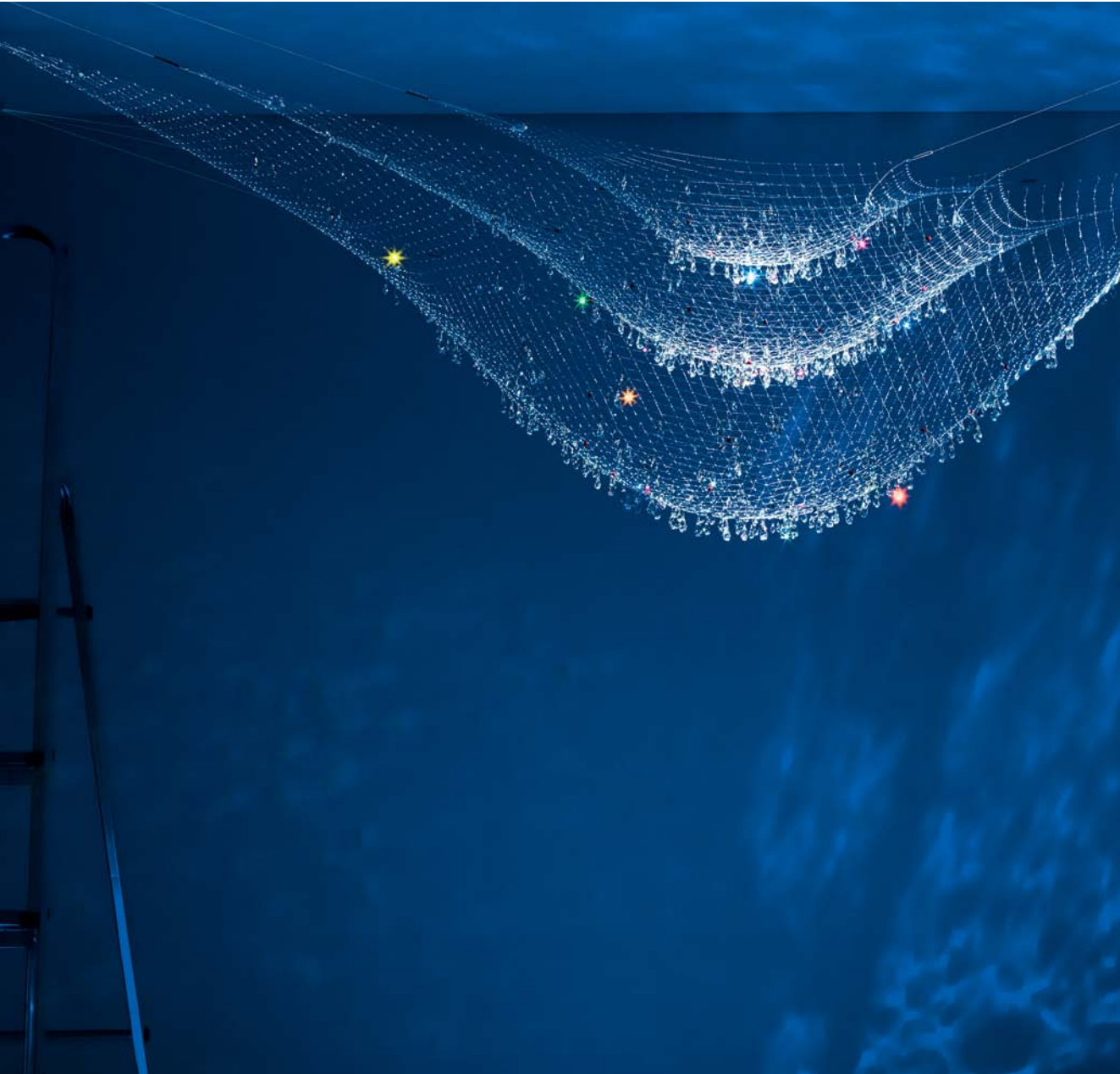
Derived from OH MAN IT'S A RAY!

ManOMan is a free, playful mobile, an up-lighting lamp that every other moment is a one of a kind. A new addition in our collection that will be available soon(er) or later.

ManOMan Ingo Maurer und Team 2011

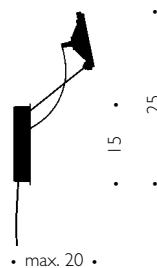
 14 x max. 60 W Halogen G9





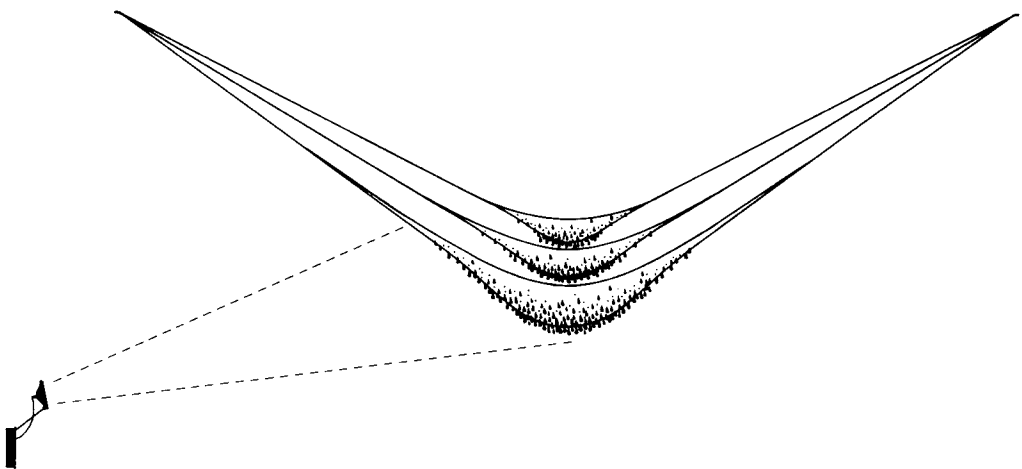
Lacrime del Pescatore Ingo Maurer 2009

Drei Nylonnetze in verschiedenen Größen, ca. 350 Kristalle. Das Leuchtmittel Ø 11 cm und der Transformator werden separat an der Wand befestigt. Nicht dimmbar. Lieferung mit Leuchtmittel. ■ Layered nylon nets in three different sizes with approximately 350 crystals. The light source Ø 11 cm and the transformer are fixed separately to the wall. Not dimmable. Complete with bulb. ■ 3 filets en nylon de tailles différentes, environ 350 cristaux. Le spot Ø 11 cm e le transformateur à accrocher séparément au mur. Non dimmable. Livrée avec ampoule. ■ 3 reti in nylon di misure differenti, 350 cristalli ca. La lampadina Ø cm. 11 e il trasformatore vengono fissata al muro separatamente. Non dimmerabile. Lampadina inclusa. ■ Tres redes de nylon en diferentes medidas, aprox. 350 cristales. La bombilla de Ø 11 cm y el transformador se sujetan en forma separada a la pared. No regulable en intensidad. Suministrada con bombilla.





One lamp, endless possibilities. You decide.



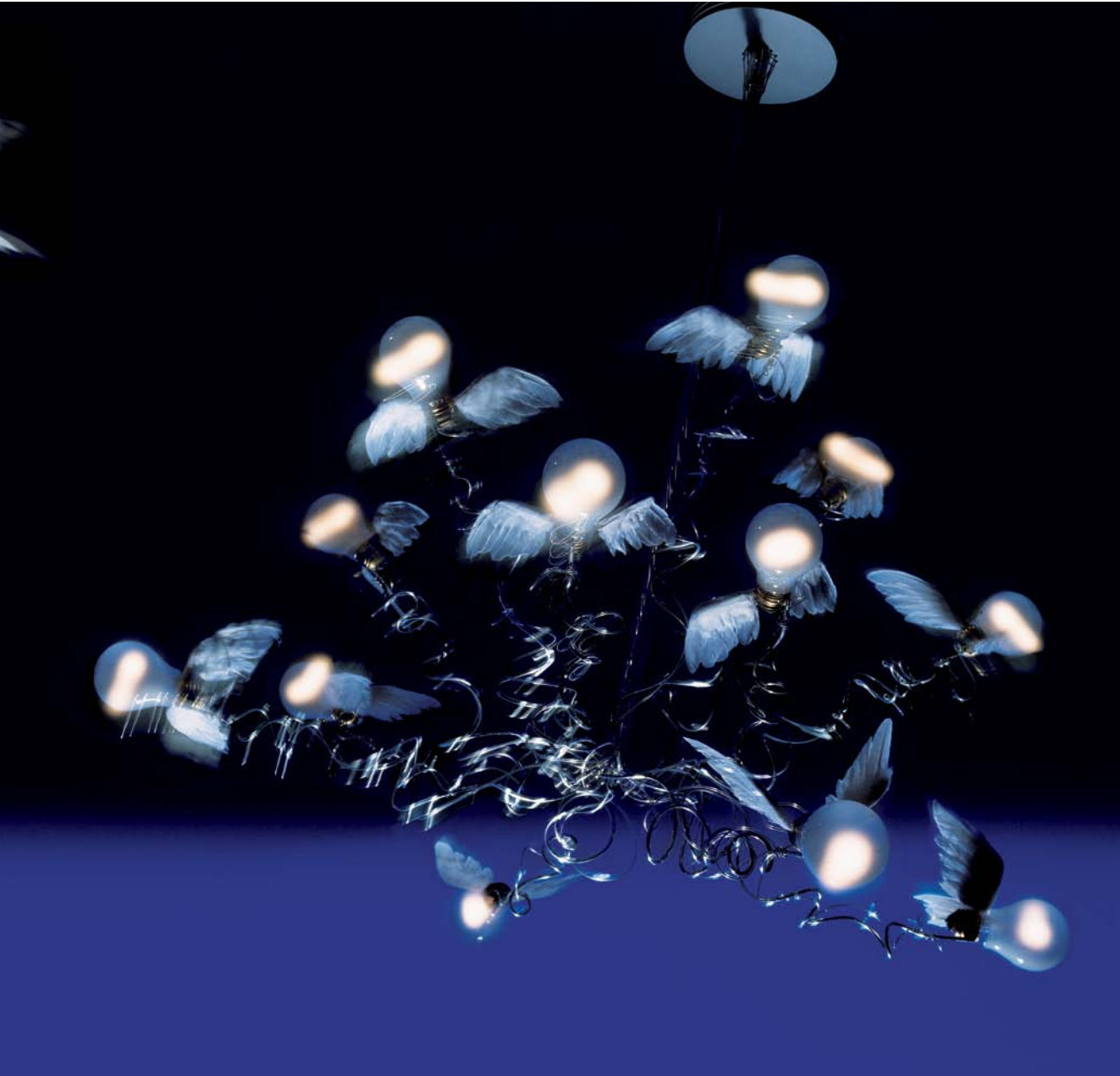
Use Me C., an optional downlight for
Lacrime del Pescatore is now available.
See page 200.



Birds Birds Birds Ingo Maurer 1992

Kronleuchter mit 24 Niedervolt-Glühlampen und Flügeln aus Gänsefedern. Im Baldachin (Ø 30 cm) integrierter Transformator, verzinnte Metallteile. Kabel in Transparent oder Rot/Blau. Sonderlängen auf Anfrage. Die einzelnen Glühlampen sind individuell beweglich. Lieferung mit Leuchtmitteln und sechs Ersatzglühlampen. ■ Chandelier with 24 low-voltage bulbs and goose-feather wings. Canopy (Ø 30 cm) with built-in transformer, tin-plated metal parts. Cables in transparent or red/blue. Alternative lengths available on request. Bulbs individually adjustable. Supplied with full set of bulbs, plus 6 spares. ■ Lustre avec 24 ampoules à bas voltage et des ailes en plumes d'oie. Transformateur intégré dans le baldaquin (Ø 30 cm), parties métalliques étamées. Câbles transparents ou rouges/bleus. Longueurs spéciales sur demande. Chaque ampoule est mobile individuellement. Livrée avec ampoules, plus 6 ampoules de rechange. ■ Lampadario con 24 lampadine a basso voltaggio e ali in piume d'oca. Trasformatore integrato nel rosone (Ø 30 cm), parti zincate in metallo. Cavi trasparenti o rossi/blu. Lunghezze speciali su richiesta. Le lampadine sono orientabili individualmente. Fornito con lampadine e 6 lampadine di ricambio. ■ Araña con 24 bombillas de bajo voltaje y alas de plumas de oca. Transformador (Ø 30 cm) integrado en el florón, piezas de metal galvanizado. Cables transparentes o en color rojo/azul. Alturas especiales a petición. Cada una de de las bombillas puede moverse individualmente. Suministrada con bombillas y seis bombillas adicionales de recambio.

24 V Halogen EU approved

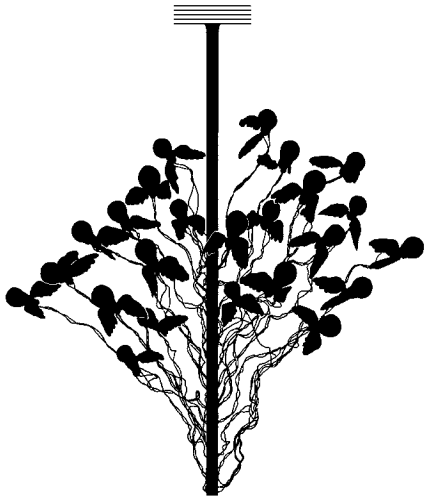


Birdie Ingo Maurer 2002

Kronleuchter mit 12 Niedervolt-Glühlampen und Flügeln aus Gänsefedern. Im Baldachin integrierter Transformator, verzinnnte Metallteile. Kabel in Rot oder Transparent. Für Raumhöhen von 230 bis 260 cm. Abhängezubehör für größere Raumhöhen separat erhältlich. Lieferung mit Leuchtmitteln und zwei Ersatzglühlampen. ■ Chandelier with 12 low-voltage bulbs and goose-feather wings. Canopy with built-in transformer; tinned metal parts. Cables in red or transparent. For ceiling heights of 230 to 260 cm. Suspension kit for higher ceilings available on request. Supplied with full set of bulbs plus two spares. ■ Lustre avec 12 ampoules à bas voltage et des ailes en plumes d'oie. Transformateur intégré dans le baldaquin, parties métalliques étamées. Câbles transparents ou rouges. Pour hauteurs de plafond de 230 à 260 cm. Accessoire de suspension disponible sur demande pour des pièces plus hautes. Livrée avec ampoules, plus deux ampoules de rechange. ■ Lampadario con 12 lampadine a basso voltaggio e ali in piume d'oca. Trasformatore integrato nel rosone, parti in metallo stagnate. Cavi rossi o trasparenti. Per soffitti con altezza da cm. 230 a cm. 260. Kit sospensione per soffitti più alti disponibile su richiesta. Fornito con lampadine e due lampadine di ricambio. ■ Araña con 12 bombillas de bajo voltaje y alas de plumas de oca. Transformador integrado en el rosetón, piezas de metal galvanizado. Cables en color rojo o transparente. Para alturas de 230 hasta 260 cm. Accesorios de sujeción disponibles para salas con mayor altura por encargo. Suministrada con bombillas y dos bombillas adicionales de recambio.

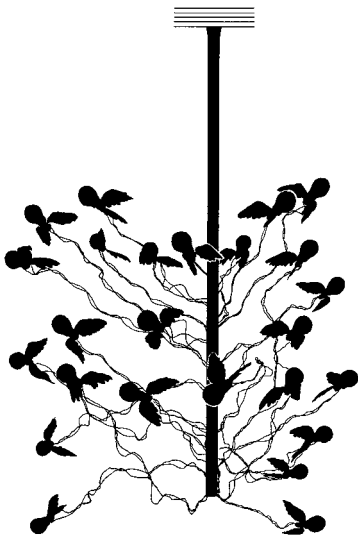
24V Halogen EU approved

 max. 120 W Halogen E27  24 V



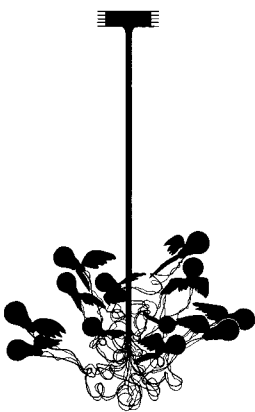
ca. 120

min. 130, max. 350



Birds, Birds, Birds

max. 240 W Halogen E27 transformer 24 V



ca. 70

100

Birdie

max. 120 W Halogen E27 transformer 24 V

Made to be co-designed by you.

Enjoy the ability to style it anyway you wish.





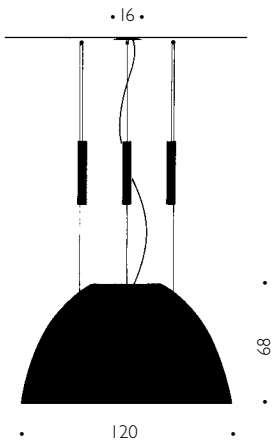
Pierre ou Paul Ingo Maurer und Team 1996

Aluminium, Edelstahl. Innenfläche in Gold, Platin oder farbig matt lackiert. Höhenverstellbar durch drei Gegengewichte. Sonderlängen auf Anfrage. Baldachin mit Abdeckscheibe Ø 16 cm. Version 1: ca. 32 kg. Version 2: Ø ca. 22 kg. Lieferung mit Leuchtmittel. ■ Aluminium, stainless steel. Inner surface gold, platinum or mat colour finish. Height adjustable by means of three counter-weights. Alternative lengths available on request. Canopy with base-plate cover Ø 16 cm. Version 1: approx. 32 kg. Version 2: approx. 22 kg. Complete with bulb. ■ Aluminium, acier inoxydable. Surface intérieure dorée à la main, platine ou vernis en couleur mat. Réglable en hauteur au moyen de trois contre-poids. Longueurs spéciales sur demande. Baldaquin avec rondelle de recouvrement 16 cm. Version 1: env. 32 kg. Version 2: env. 22 kg. Livrée avec ampoule. ■ Alluminio, acciaio inossidabile, superficie interna in oro, platino vernice colorata opaca. Altezza regolabile mediante tre contrappesi. Lunghezze speciali su richiesta. Rosone con piastra di copertura Ø 16 cm. Versione 1: ca. 32 kg. Versione 2: ca. 22 kg. Lampadina inclusa. ■ Aluminio, acero fino. Superficie interior en oro, platino o lacado en color mate. Altura ajustable gracias a tres pesos. Medidas especiales por encargo. Florón con tapa corredera de Ø 16 cm. Versión 1: aprox. 32 kg. Versión 2: aprox. 22 kg. Suministrada con bombilla.



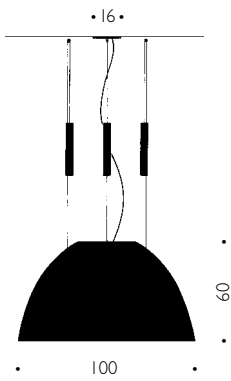
XXL Dome Ingo Maurer 1999

Fiberglas, außen alusilber, innen leucht-pink, -orange, -rot oder -grün matt lackiert. Sonderfarben möglich. Sonderlängen auf Anfrage. Gewicht ca. 45 kg. Lieferung mit Leuchtmittel. ■ Fibreglass, exterior aluminium-silver, interior fluorescent pink, orange, red or green mat lacquer. Other colours on request. Alternative lengths available on request. Weight approx. 45 kg. Bulb included. ■ Fibre de verre, extérieur vernis couleur argent, intérieur vernis mat, rose pink, orange, rouge ou vert fluorescent. Couleurs spéciales possibles. Longueurs spéciales sur demande. Poids env. 45 kg. Livrée avec ampoule. ■ Vetroresina, superficie esterna verniciata color argento, superficie interna luminescente pink, arancione, rosso o verde, vernice opaca. Colori speciali su richiesta. Lunghezze speciali su richiesta. Peso ca. 45 kg. Lampadina inclusa. ■ Fibra de vidrio, por fuera plateado, por dentro rosa, naranja, rojo o verde luminoso barnizado mate. Posibilidad de colores especiales. Longitudes especiales por encargo. Peso aprox. 45 kg. Suministrada con bombilla.



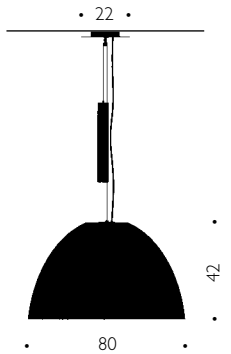
Pierre ou Paul

Version 1 max. 250 W E27 cable 400 cm



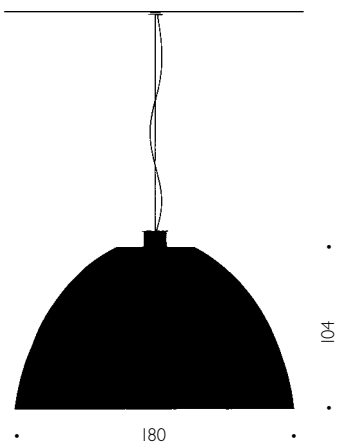
Pierre ou Paul

Version 2 max. 250 W E27 cable 400 cm



Pierre ou Paul S

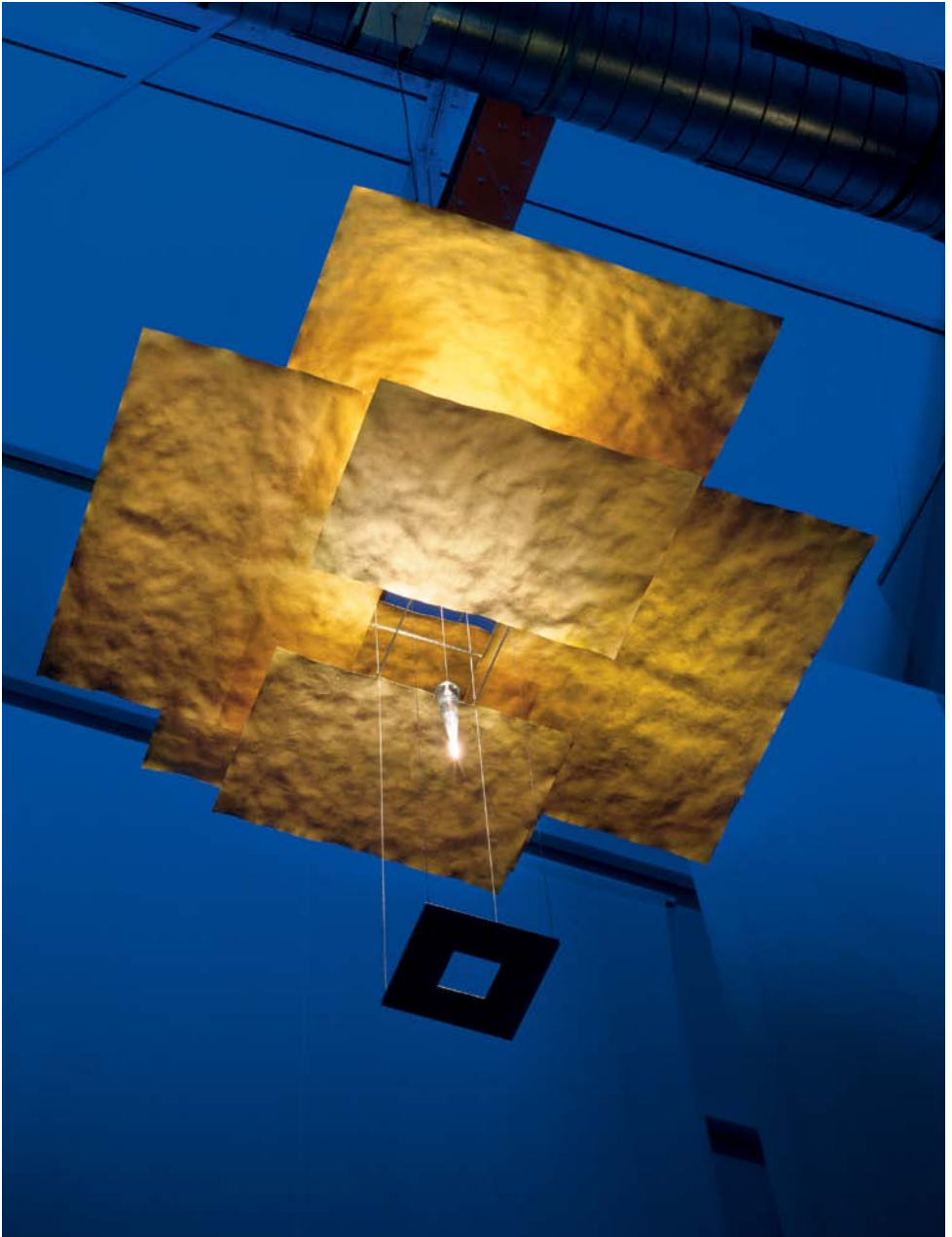
max. 250 W E27 cable 400 cm
With one counterweight only



XXL Dome

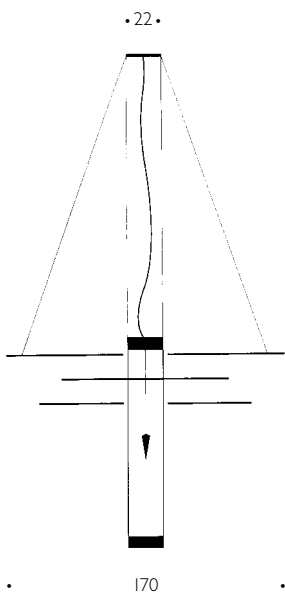
max. 250 W E27
CDM Version: max. 150 W HID G12 cable: 400 cm



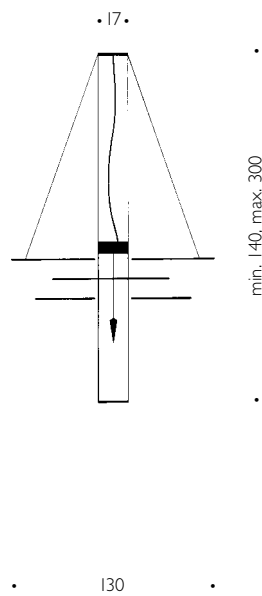


Oh Mei Ma *Ingo Maurer 1993*

Sechs Blätter aus versilbertem Papier. Senklot aus Metall. Auch mit blattvergoldetem Papier und Senklot aus Plexiglas lieferbar. Sonderlängen auf Anfrage. Lieferung mit Leuchtmittel. ■ Six sheets of silver-coated paper. Plumb made of steel. Gold-plated version also available, with plumb in plexiglass. Alternative lengths available on request. Complete with bulb. ■ Six feuilles en papier argenté. Fil à plomb en acier. Egalement disponible en papier doré à la feuille avec fil à plomb en plexiglas. Longueurs spéciales sur demande. Livrée avec ampoule. ■ Sei fogli di carta argentata. Pendolo in acciaio. È disponibile anche la versione in carta dorata con pendolo in plexiglas. Lunghezze speciali su richiesta. Lampadina inclusa. ■ Seis hojas de papel plateado. Péndulo de metal. Las hojas también están disponibles en papel de color dorado con péndulo de plexiglas. Medidas especiales por encargo. Suministrada con bombilla.



Oh Mei Ma Kabir



Oh Mei Ma



Oh Mei Ma Kabir *Ingo Maurer und Team 1997/2007*

Sechs Blätter aus versilbertem Papier. Senklot aus Metall. Auch mit blattvergoldetem Papier und Senklot aus Plexiglas lieferbar. Sonderlängen auf Anfrage. Lieferung mit Leuchtmitteln. ■ Six sheets of silver-coated paper. Plumb made of steel. Gold-plated version also available, with plumb in plexiglass. Alternative lengths available on request. Complete with bulbs. ■ Six feuilles en papier argenté. Fil à plomb en acier. Egalement disponible en papier doré à la feuille avec fil à plomb en plexiglas. Longeurs spéciales sur demande. Livrée avec ampoules. ■ Sei fogli di carta argentata. Pendolo in acciaio. È disponibile anche la versione in carta dorata con pendolo in plexiglas. Lunghezze speciali su richiesta. Lampadine incluse. ■ Seis hojas de papel plateado. Péndulo de metal. Las hojas también están disponibles en papel de color dorado con péndulo de plexiglás. Medidas especiales por encargo. Suministrada con bombillas.

Oh Mei Ma Kabir Weiss *Ingo Maurer und Team 1997/2007*

Metall, Glas. Sechs Blätter aus Aluminium, matt weiß lackiert. Sonderlängen auf Anfrage. Lieferung mit Leuchtmitteln. ■ Metal, glass. Six sheets of aluminium, mat white finish. Alternative lengths available on request. Complete with bulbs. ■ Métal, verre. Six feuilles en tôle d'aluminium, vernis en couleur blanc mat. Longeurs spéciales sur demande. Livrée avec ampoules. ■ Metallo, vetro. Sei fogli in lamiera d'alluminio, verniciatura bianca opaca. Lunghezze speciali su richiesta. Lampadine incluse. ■ Metal, cristal. Seis hojas de aluminio blancas barnizadas en mate. Medidas especiales por encargo. Suministrada con bombillas.



Oh Mei Ma Weiss *Ingo Maurer und Team 1997/2007*

Metall, Glas. Sechs Blätter aus Aluminium, matt weiß lackiert. Sonderlängen auf Anfrage. Lieferung mit Leuchtmitteln. ■ Metal, glass. Six sheets of aluminium, mat white finish. Alternative lengths available on request. Complete with bulbs. ■ Métal, verre. Six feuilles en tôle d'aluminium, vernis en blanc mat. Longueurs spéciales sur demande. Livrée avec ampoules. ■ Metallo, vetro. Sei fogli in lamiera d'alluminio, verniciatura bianca opaca. Lunghezze speciali su richiesta. Lampadina inclusa. ■ Metal, cristal. Seis hojas de aluminio blancas barnizadas en mate. Medidas especiales por encargo. Suministrada con bombilla.



YUU 200 Ingo Maurer und Team 2005

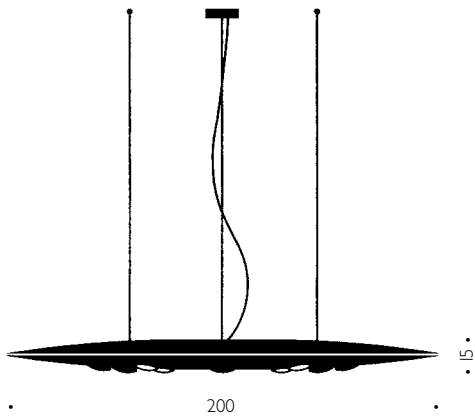
Fiberglas, Aluminium, Stahl. Transparent oder weiß lackiert. Wattage und Leuchtmittel variabel, Produktion auf Anfrage. ■ Fibreglass, aluminium, steel. Transparent or lacquered white. Wattage and light sources variable, fabrication on request. ■ Fibre de verre, aluminium, acier. Transparent ou lacqué blanc. Puissance et intensité lumineuse variables, fabrication sur demande. ■ Vetoresina, alluminio, acciaio. Trasparente o con verniciatura bianca. Wattaggio e lampadine variano secondo il modello, produzione su richiesta. ■ Lámina de fibras de vidrio, aluminio, acero. Transparente o lacado en blanco. Potencia e intensidad variable. Producción por encargo.



Wafer Ingo Maurer und Team 2006

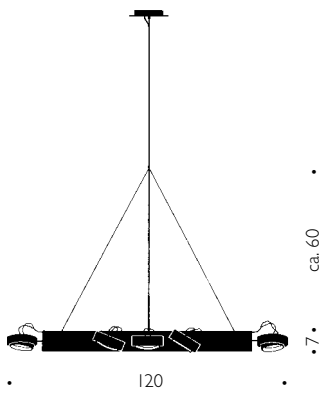
Stahl, Aluminium. 7 Leuchtstoffröhren. Die 4 x 3 Halogen-Spots können mit Kardan-Gelenken flexibel ausgerichtet werden. Integrierte Vorschaltgeräte und Transformatoren.

■ Steel, aluminium. 7 fluorescent lamps. Cardan joints allow the 4 x 3 halogen spotlights to be freely adjustable. Integrated electronic ballasts and transformers. ■ Acier, aluminium. 7 ampoules fluorescentes. Une articulation à cardan permet le libre ajustement des 4 x 3 spots halogènes. Ballast électronique intégré et transformateurs. ■ Acciaio, alluminio. 7 lampade fluorescenti. Possibilità di orientare liberamente 4 x 3 spot alogeni mediante un giunto cardanico. Alimentatori e trasformatori integrati. ■ Aluminio, acero. 7 tubos fluorescentes. Los focos halógenos 4 x 3 pueden alinearse de forma flexible con articulaciones Kardan. Aparatos preconectados y transformadores integrados.



YUU 200

light sources variable



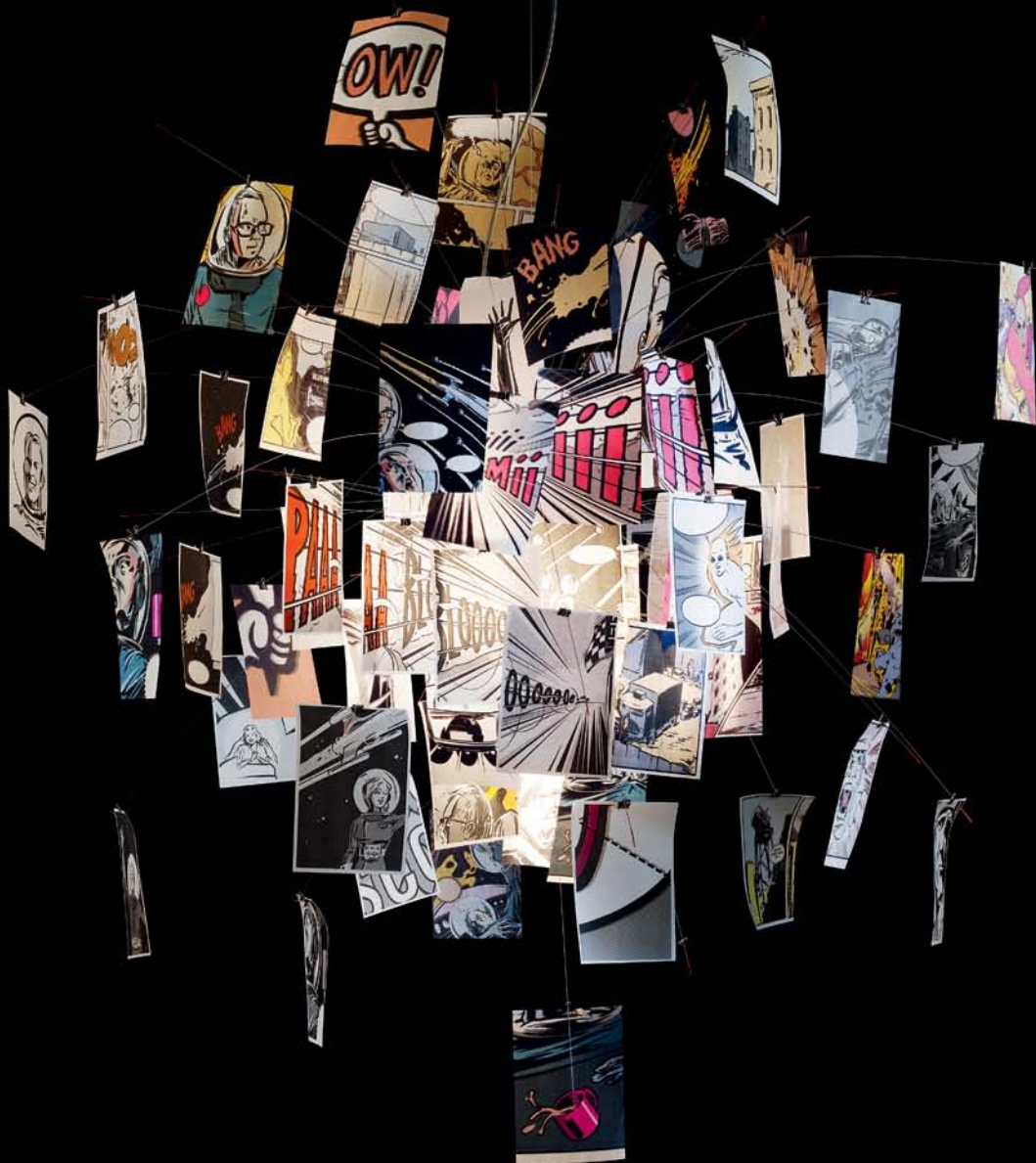
Wafer

7 x max. 24 W G5 12 x max. 65 W Halogen G53
transformer 12 V









Bang Boom Zettel'z* Ingo Maurer 2010

Japanpapier, Edelstahl, hitzebeständiges satiniertes Glas. Baldachin Ø 11 cm. 80 bedruckte Blätter DIN A5, Zeichnungen von Thilo Rothacker. Lieferung mit Leuchtmitteln. ■

Japanese paper, stainless steel, heat-resistant satin-frosted glass. Canopy diameter Ø 11 cm.

80 printed paper sheets DIN A5, drawings by Thilo Rothacker. Complete with bulbs. ■

Acier inoxydable, verre satiné résistant à la chaleur, papier japonais. Baldaquin Ø 11 cm.

80 feuilles DIN A5 imprimées, dessins par Thilo Rothacker. Livrée avec ampoules. ■

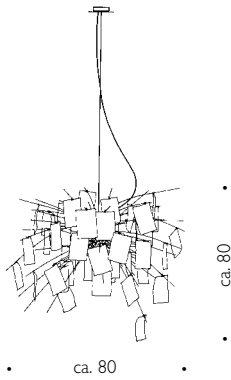
Acciaio inossidabile, vetro satinato termoresistente, carta giapponese. Rosone Ø cm. 11. 80

fogli prestampati DIN A5, disegni di Thilo Rothacker. Lampadine incluse. ■

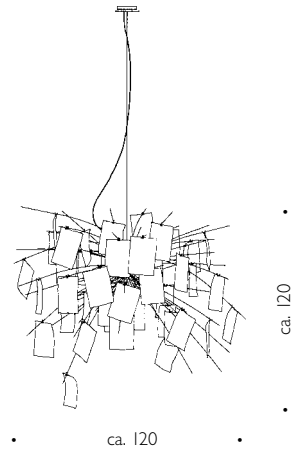
Papel japonés, acero inoxidable, vidrio satinado, termoestable. Rosetón Ø 11 cm. 80 hojas DIN A5

impresas, dibujos de Thilo Rothacker. Suministrada con bombillas.

* Limited Edition



Zettel'z 6



Bang Boom Zettel'z
Zettel'z 5

Zettel'z 6 Ingo Maurer 1998

Japanpapier, Edelstahl, hitzebeständiges satiniertes Glas. Baldachin Ø 11 cm. 40 bedruckte und 40 unbedruckte Blätter DIN A6. Lieferung mit Leuchtmittel. Ein Set mit 80 unbedruckten Blättern kann nachbestellt werden. ■ Japanese paper, stainless steel, heat-resistant satin-frosted glass. Canopy Ø 11 cm. 40 printed and 40 blank paper sheets DIN A6. Complete with bulb. Replacement set of 80 blank paper sheets available. ■ Acier inoxydable, verre satiné résistant à la chaleur, papier japonais. Baldaquin Ø 11 cm. 40 feuilles imprimées et 40 feuilles blanches DIN A6. Livrée avec ampoule. 80 feuilles blanches de rechange disponibles. ■ Carta giapponese, acciaio inossidabile, vetro satinato termoresistente. Rosone Ø cm. 11. 40 fogli prestampati e 40 fogli bianchi DIN A6. Lampadina inclusa. ■ Papel japonés, acero inoxidable, vidrio satinado, termoestable. Florón Ø 11 cm. 40 hojas DIN A6 impresas y 40 en blanco. Suministrada con bombilla. Puede solicitarse un paquete de 80 hojas adicionales en blanco.

 max. 250 W E27  200 cm

Zettel'z 5 Ingo Maurer 1997

Japanpapier, Edelstahl, hitzebeständiges satiniertes Glas. Baldachin Ø 11 cm. 31 bedruckte und 49 unbedruckte Blätter DIN A5. Lieferung mit Leuchtmitteln. Ein Set mit 80 unbedruckten Blättern kann nachbestellt werden. ■ Japanese paper, stainless steel, heat-resistant satin-frosted glass. Canopy Ø 11 cm. 31 printed and 49 blank paper sheets DIN A5. Complete with bulbs. Replacement set of 80 blank paper sheets available. ■ Acier inoxydable, verre satiné résistant à la chaleur, papier japonais. Baldaquin Ø 11 cm. 31 feuilles imprimées et 49 feuilles blanches DIN A5. Livrée avec ampoules. 80 feuilles blanches de rechange disponible. ■ Carta giapponese, acciaio inossidabile, vetro satinato termoresistente. Rosone Ø cm. 11. 31 fogli prestampati e 49 fogli bianchi DIN A5. Lampadine incluse. Possibilità di integrare con 80 fogli bianchi. ■ Papel japonés, acero inoxidable, vidrio satinado, termoestable. Rosetón Ø 11 cm. 31 hojas DIN A5 impresas y 49 no impresas. Suministrada con bombillas. Puede solicitarse un paquete con 80 hojas sin imprimir.

 max. 250 W E27, max. 75 W PAR 30 Halogen 30° E27  330 cm





24 Karat Blau Axel Schmid 2005

Metall, Kunststoff, Gold. Optional einsetzbarer Reflektor. Die goldenen Blenden haben jeweils vier Bohrungen, mit denen sie an dem Stabkreuz in verschiedenen Winkeln aufgehängt werden können. Kabel und Stabkreuz in Rot oder Schwarz. Lieferung mit Leuchtmittel. ■ Metal, plastic, gold. Reflector for optional use. The golden shades have four holes each, with which they can be suspended on the rods in various angles. Cable and rods in red or black. Complete with bulb. ■ Métal, matière plastique, feuille d'or. Réflecteur optionnel. Les quatre écrans peuvent être suspendus dans différents angles et positions. Câble et tiges en rouge ou noir. Livrée avec ampoule. ■ Metallo, materiale sintetico, oro. Riflettore per uso opzionale. I quattro paralumi d'oro possono essere appesi sull'asta a croce in vari angoli e posizioni. Cavo e asta in rosso o nero. Lampadina inclusa. ■ Metal, plástico, oro. Opcional con reflector montable. Las pantallas doradas tienen cuatro agujeros cada una que permiten la sujeción al varillaje en diferentes ángulos. Cable y astas en rojo o negro. Suministrada con bombilla.



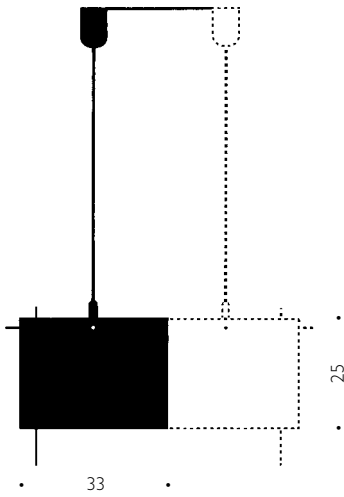
24 Karat Blau M Axel Schmid 2005

Material wie 24 Karat Blau. Lieferumfang: Zwei Verbindungselemente, Stabkreuz, Baldachin, Kabel, Fassung, zwei Blenden, Reflektor, Leuchtmittel. Ein Set vergrößert 24 Karat Blau um etwa eine Blendenbreite. Die Stabkreuze werden mit Verbindungselementen fixiert. Mehrere Sets ermöglichen eine individuelle Gestaltung von unterschiedlichen Gruppierungen. ■ Material same as 24 Karat Blau. Set includes: Two connectors, suspension rod, canopy, cable, socket, two shades, reflector, bulb. The set extends 24 Karat Blau about one shade's width. Connectors fix the suspension rods to each other. The use of several sets allows an individual layout in a variety of forms and sizes. ■ Même matériel que la 24 Karat Blau. Inclus: deux éléments de fixation, tige en forme de croix, baldachin, câble, douille, deux écrans, réflecteur, ampoule. Un set agrandit 24 Karat Blau d'environ un écran. Les tiges en forme de croix sont fixées par les éléments de fixation. Plusieurs sets permettent une forme personnelle et individuelle de 24 Karat Blau. ■ Materiale come 24 Karat Blau. Sono inclusi: due elementi di collegamento, asta a croce, rosone, cavo, portalampada, due paralumi, riflettore, lampadina. Un set consente di ampliare 24 Karat Blau della larghezza di un paralume circa. Le aste a croce vengono fissate mediante gli elementi di collegamento. L'impiego di più d'un set permette varie composizioni di forma e misura individuali. ■ Mismo material que la 24 Karat Blau. Suministro: Dos elementos de conexión, varillaje, florón, rosetón, cable, casquillo, dos pantallas, reflector, bombilla. Un set amplía la 24 Karat Blau en aproximadamente un ancho de pantalla. El varillaje es fijado por medio de elementos de conexión. Varios sets permiten posibilitan un diseño variablemente agrupado.



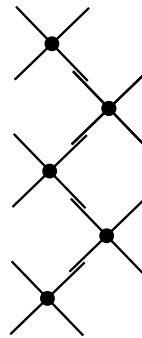
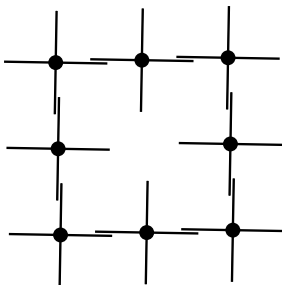
24 Karat Blau

max. 60 W (230 V: Halogen) E27 cable 230/450 cm



24 Karat Blau M

max. 60 W (230 V: Halogen) E27 cable 230/450 cm

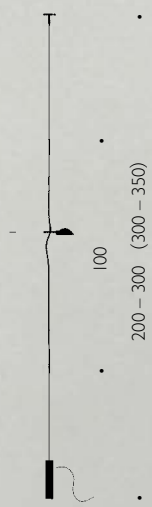






Hot Achille *Ingo Maurer und Team 1994*

Edelstahl, Aluminiumreflektor mit Schutzglas, Koaxialkabel. Für Raumhöhen bis 300 cm oder 350 cm. Lieferung mit Leuchtmittel. ■ Stainless steel, aluminium reflector with protective glass cover, coaxial cable. Complete with bulb. ■ Acier inoxydable, réflecteur en aluminium avec verre protecteur; câble coaxial. Adapté jusqu'à une hauteur de pièce de 300 cm ou 350 cm. Livrée avec ampoule. ■ Acciaio inossidabile, riflettore in alluminio con vetro di protezione, cavo coassiale. Per soffitti con altezza fino a cm. 300 o 350. Lampadina inclusa. ■ Acero inoxidable, reflector de aluminio con cristal protector; cable coaxial. Apto para ambientes con altura de hasta 300 cm o 350 cm. Suministrada con bombilla.



• 26 •

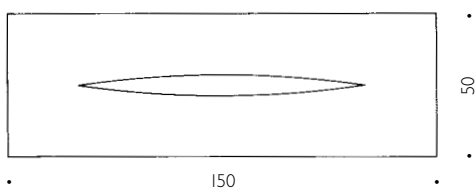
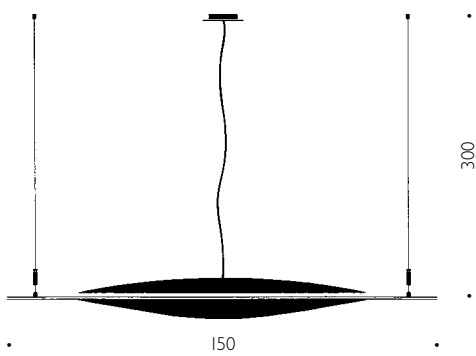




Schlitz *Ingo Maurer 2002*

Aluminium, Glas. Up- und Downlights getrennt schaltbar. Abhängung an zwei Stahlseilen.

■ Aluminium, glass. Up- and downlights separately switchable. Suspension on two steel wires. ■ Aluminium, verre. Up et downlights à allumage séparé. Suspendue à deux fils d'acier. ■ Alluminio, vetro. Uplights e downlights comandabili separatamente. Sospesa a due fili d'acciaio. ■ Aluminio, cristal. La iluminación hacia arriba y hacia abajo se pueden encender indistintamente. Sujeción en mediante dos cables de acero.



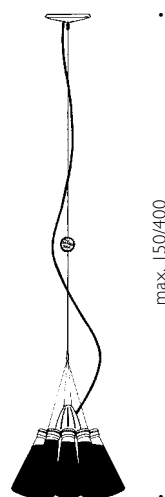


Canned Light *Christoph Matthias, Hagen Szech 2003*

Aluminium, Edelstahl, Kunststoff. Eine Konservendose, befüllt mit Glühlampe, Reflektor, Fassung, Kabel und Schalter wird zur Hänge- oder Wandlampe. Aufputz-Montage mit Abdeckscheibe weiß Ø 8 cm. Stufenlos höhenverstellbar durch Umlenkrolle und Justier-ring. ■ Aluminium, stainless steel, plastic. A tin can, containing lightbulb, reflector, socket, cable and switch, turns into a hanging or wall lamp. Surface-mounted ceiling fixture with white baseplate cover Ø 8 cm. Height freely adjustable with pulley and ring. ■ Aluminium, acier inoxydable, matière plastique. Une boîte de conserves, contenant ampoule, réflecteur, douille, câble, interrupteur se transforme en suspension ou applique. Montage sur crépi avec rondelle blanche de recouvrement Ø 8 cm. Réglable en hauteur sans graduation par poulie de renvoi et anneau coulissant. ■ Alluminio, acciaio inossidabile, materiale sintetico. Un barattolo da conserva, contenente lampadina, portalampada, riflettore, cavo e interruttore, si trasforma in una lampada da sospensione o da parete. Scatola di derivazione esterna con piastra bianca di copertura Ø 8 cm. Regolazione continua dell'altezza con carrucola e anello di bloccaggio. ■ Aluminio, acero inoxidable, plástico. Un bote de conservas, relleno con bombilla, reflector y portalámpara, cable e interruptor se transforman en una lámpara colgante o de pared. Montaje en el enlucido con cubierta blanca Ø 8 cm. Ajuste gradual de la altura a través de una polea y un anillo de ajuste.

© 2003 and trademark by Campbell Soup Company used under license.
All rights reserved.





23

Campari Light Raffaele Celentano 2002

Zehn originale Campari-Soda-Flaschen, einzeln abnehmbar, Kunststoff, Metall. Stufenlos höhenverstellbar durch Campari-Kronenkorken. Transparenter Baldachin, Ø 13 cm. Für Raumhöhen bis 300 cm, Sonderlänge für Raumhöhen bis 550 cm. Lieferung mit Leuchtmittel. ■ Ten original Campari Soda bottles, individually detachable. Plastic, metal. Height freely adjustable via Campari bottle cap. Transparent canopy, Ø 13 cm. For ceiling heights up to 300 cm. Special length for ceiling heights up to 550 cm. Complete with bulb. ■ Dix bouteilles originales de Campari Soda, détachables individuellement, matière plastique, métal. Réglable en hauteur sans graduation par une capsule Campari. Baldaquin transparent, Ø 13 cm. Pour hauteur de pièce jusqu'à 300 cm. Longueur spéciale pour hauteur de pièce jusqu'à 550 cm. Livrée avec ampoule. ■ Dieci bottiglie di Campari Soda originali, staccabili singolarmente, materiale sintetico, metallo. Altezza regolabile in continuo mediante un tappo Campari. Rosone trasparente, Ø 13 cm. Per soffitti con altezze fino a 300 cm. Lunghezza speciale per soffitti fino a 550 cm. Lampadina inclusa. ■ Diez botellas originales de Soda Campari, de extracción individual, plástico, metal. Ajuste gradual de la altura a través de las chapas Campari. Florón transparente, Ø 13 cm. Para ambientes con altura de hasta 300 cm, largo especial para alturas de hasta 550 cm. Suministrada con bombilla.



max. 125/400

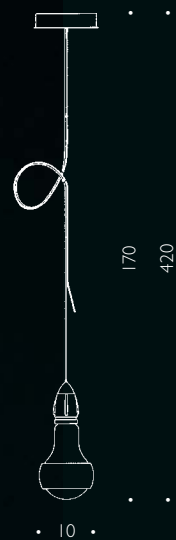
21

28



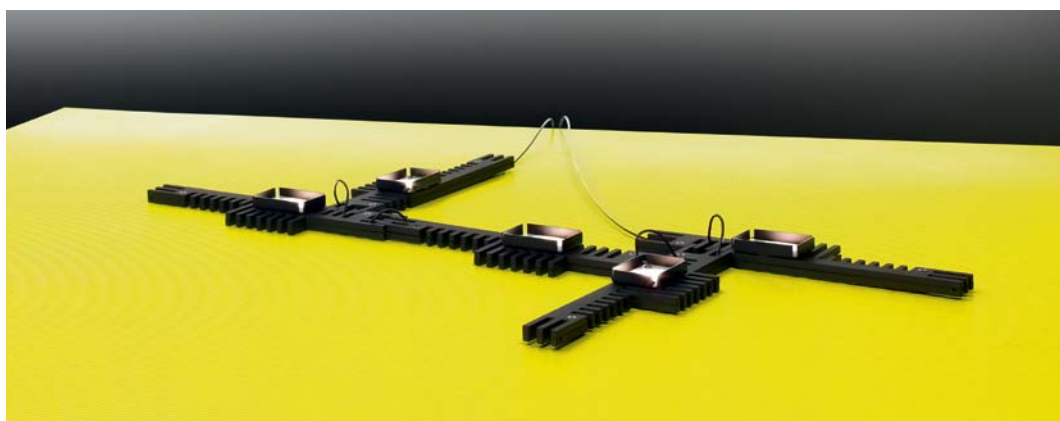
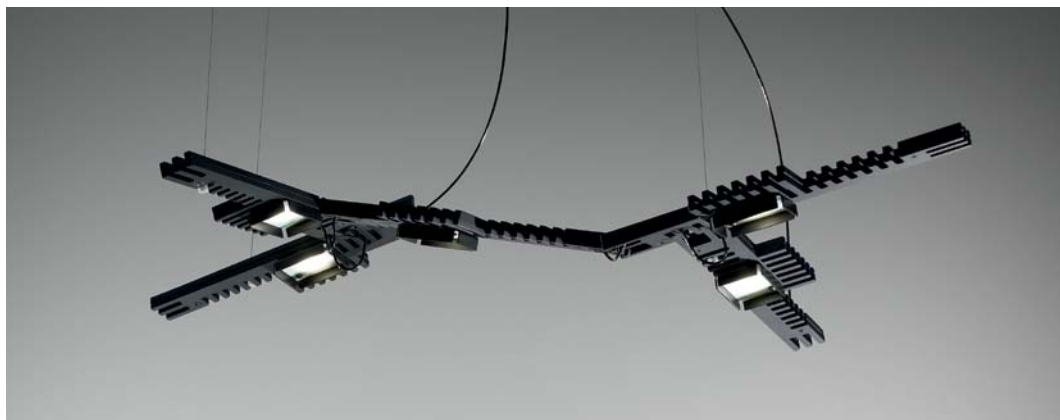
Lucetto *Bernhard Dessecker, Ingo Maurer und Team 1995*

Glas, Kunststoff, hitzebeständiges Blendenmaterial. Stufenlos höhenverstellbar durch Umlenkrolle und Justierring. Baldachin Ø 13 cm, transparent. Für Raumhöhen bis 300 und 550 cm. Lieferung mit Leuchtmittel. ■ Glass, plastic, heat-resistant shade. Height freely adjustable with pulley and ring. Canopy, Ø 13 cm, transparent. For ceiling heights up to 300 and 550 cm. Complete with bulb. ■ Verre, matière plastique, écrans résistant à la chaleur. Régable en hauteur sans graduation par poulie de renvoi et anneau coulissant. Baldaquin Ø 13 cm, transparent. Pour hauteurs de pièce jusqu'à 300 et 550 cm. Livrée avec ampoule. ■ Vetro, materiale sintetico, schermo termoresistente. Regolazione continua dell'altezza con carrucola e anello di bloccaggio. Rosone Ø cm. 13, trasparente. Per soffitti con altezze fino cm. 300 e 550. Lampadina inclusa. ■ Vidrio, plástico, material de pantalla termoestable. Ajuste gradual de la altura a través de una polea y un anillo de ajuste. Florón, Ø 13 cm, transparente. Para alturas hasta 300 y 550 cm. Suministrada con bombilla.



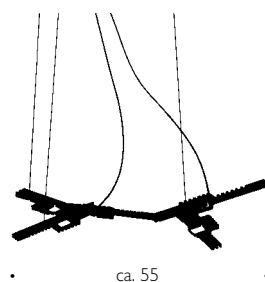
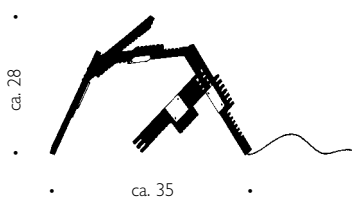
Johnny B. Good Ingo Maurer, Bernhard Dessecker 2002

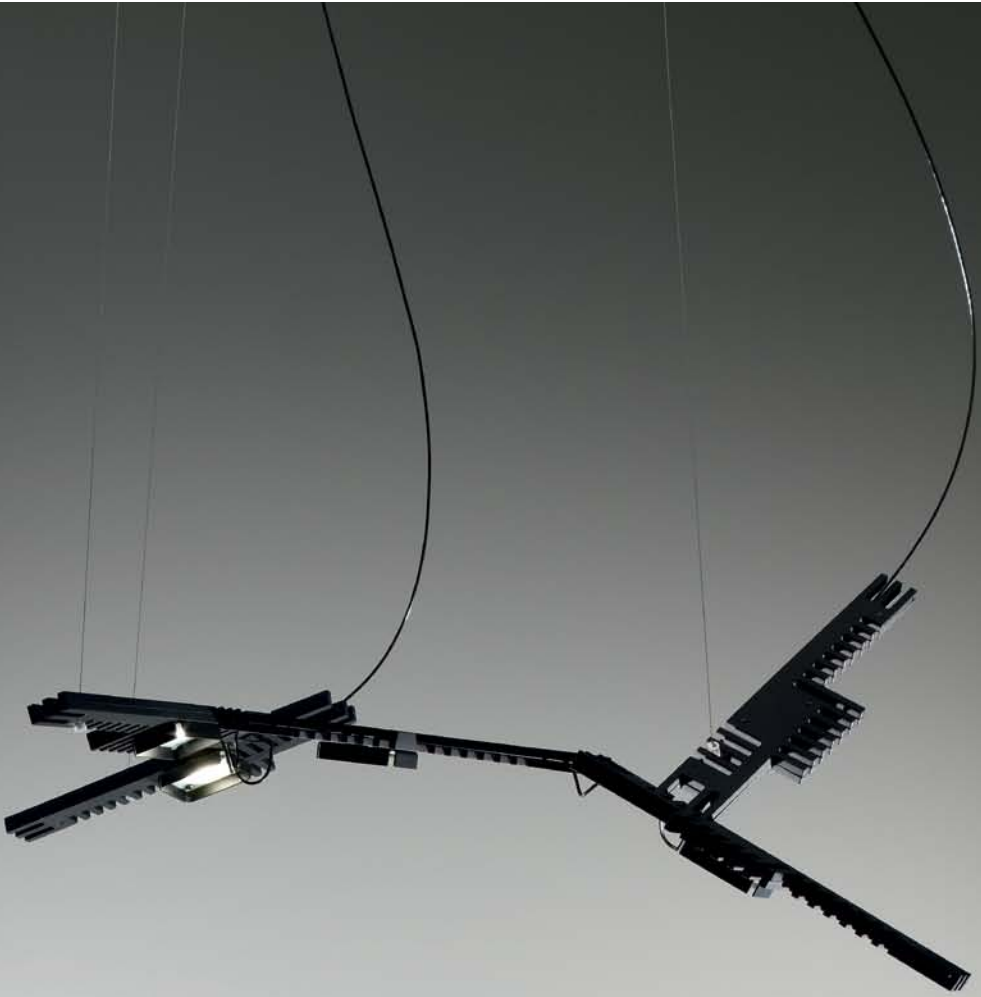
Glas, Teflon, Kunststoff. Höhenverstellbar. Weißer Blendenring. Baldachin Ø 14 cm. V1: Stufenlos dimmbar durch Sensorschalter mit Memo-Funktion, für Raumhöhen bis 300 cm. V2: ohne Sensorschalter, d. h. ohne das rote Kabel. Für Raumhöhen bis 550 cm. Lieferung mit Leuchtmittel. ■ Glass, Teflon, plastic. Height adjustable. White shade ring. Canopy Ø 14 cm. V1: Continuously variable dimmer with sensor switch and memo function, for ceiling heights up to 300 cm. V2: no sensor switch, that is without the red cable. For ceiling heights up to 550 cm. Complete with bulb. ■ Verre, téflon, matière plastique. Réglable en hauteur. Abat-jour blanc. Baldaquin Ø 14 cm. V1: réglage d'intensité lumineuse continu par interrupteur sensor avec fonction mémo, pour des hauteurs de plafond jusqu'à 300 cm. V2: sans interrupteur, c'est-à-dire sans le cable rouge. Pour des hauteurs de plafond jusqu'à 550 cm. Livrée avec ampoule. ■ Vetro, Teflon, materiale sintetico. Regolabile in altezza. Schermo bianco. Rosone Ø 14 cm. V1: Regolazione continua della luminosità mediante un interruttore a sensore con funzione di memoria, per soffitti con altezza fino a 300 cm. V2: senza interruttore a sensore, senza il cavo rosso. Per soffitti con altezza fino a 550 cm; varialuce raccomandato. Lampadina inclusa. ■ Vidrio, teflón, plástico. Con ajuste de altura. Disco blanco para diafragma. Florón Ø 14 cm. V1: dimmer sin escalones a través del interruptor de sensor con función de memorización, para ambientes con una altura de hasta 300 cm. V2: sin interruptor de sensor, es decir sin el cable rojo. Para ambientes con altura de hasta 550 cm. Suministrada con bombilla.



Manifold Axel Schmid 2011

Eloxiertes Aluminium in Schwarz. Die fünf identischen Metallelemente sind mit Gelenken verbunden. Manifold ist Hänge-, Tisch- oder Wandlampe. ■ Anodized aluminium in black. Five identical metal parts connected by flexible joints. Manifold is a suspension, table or wall lamp. ■ Aluminium anodisé en noir: Cinq éléments métalliques, joints par des articulations. Manifold est suspension, applique ou lampe de table. ■ Alluminio anodizzato nero. Cinque elementi metallici, collegati con giunti flessibili. Manifold è una lampada a sospensione, da tavolo o da parete. ■ Aluminio anodizado en negro. Cinco elementos metálicos, conectados con articulaciones. Manifold es una lámpara de suspensión, de sobremesa o aplique.







Max.Up & Down Ingo Maurer 2003

Aluminium, Metall, Kunststoff, Silikon. In einem Bereich von ca. 50 cm stufenlos höhenverstellbar durch einen Aufrollmechanismus im Baldachin. Reflektor in Weiß oder Aluminium Hochglanz. Lieferung mit Leuchtmittel. ■ Aluminium, metal, plastic, silicone. In a limited range of approx. 50 cm freely adjustable in height by means of a coiling mechanism integrated in the canopy. Reflector in white, or highly polished aluminium. Complete with bulb. ■ Aluminium, métal, matière plastique, silicone. Réglable en hauteur sans graduation sur environ 50 cm par un mécanisme d'enroulement intégré dans le baldachin. Réflecteur en blanc ou aluminium poli. Livrée avec ampoule. ■ Alluminio, metallo, materiale sintetico, silicone. Regolazione continua dell'altezza entro un margine di ca. 50 cm grazie ad un meccanismo di avvolgimento all'interno del rosone. Riflettore in bianco o alluminio lucido. Lampadina inclusa. ■ Aluminio, metal, plástico, silicona. Altura variable de 50 cm sin escalones gracias a su mecanismo de devanado en el baldachín. Reflector en blanco o en aluminio brillante. Suministrada con bombilla.



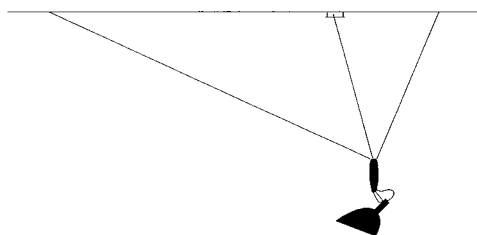
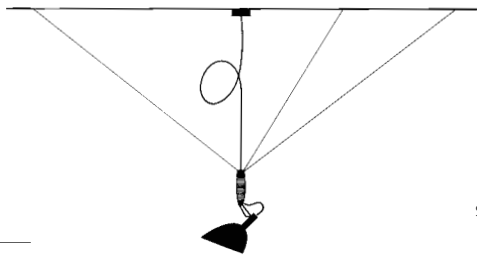
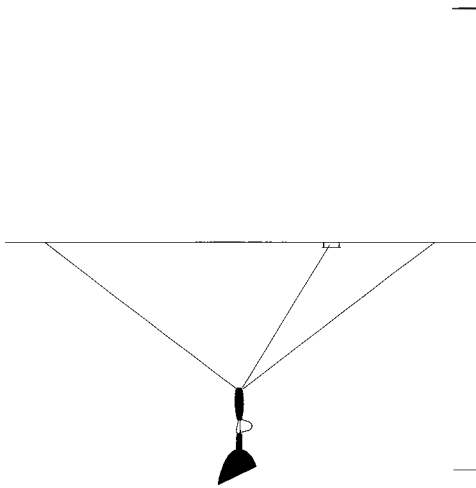
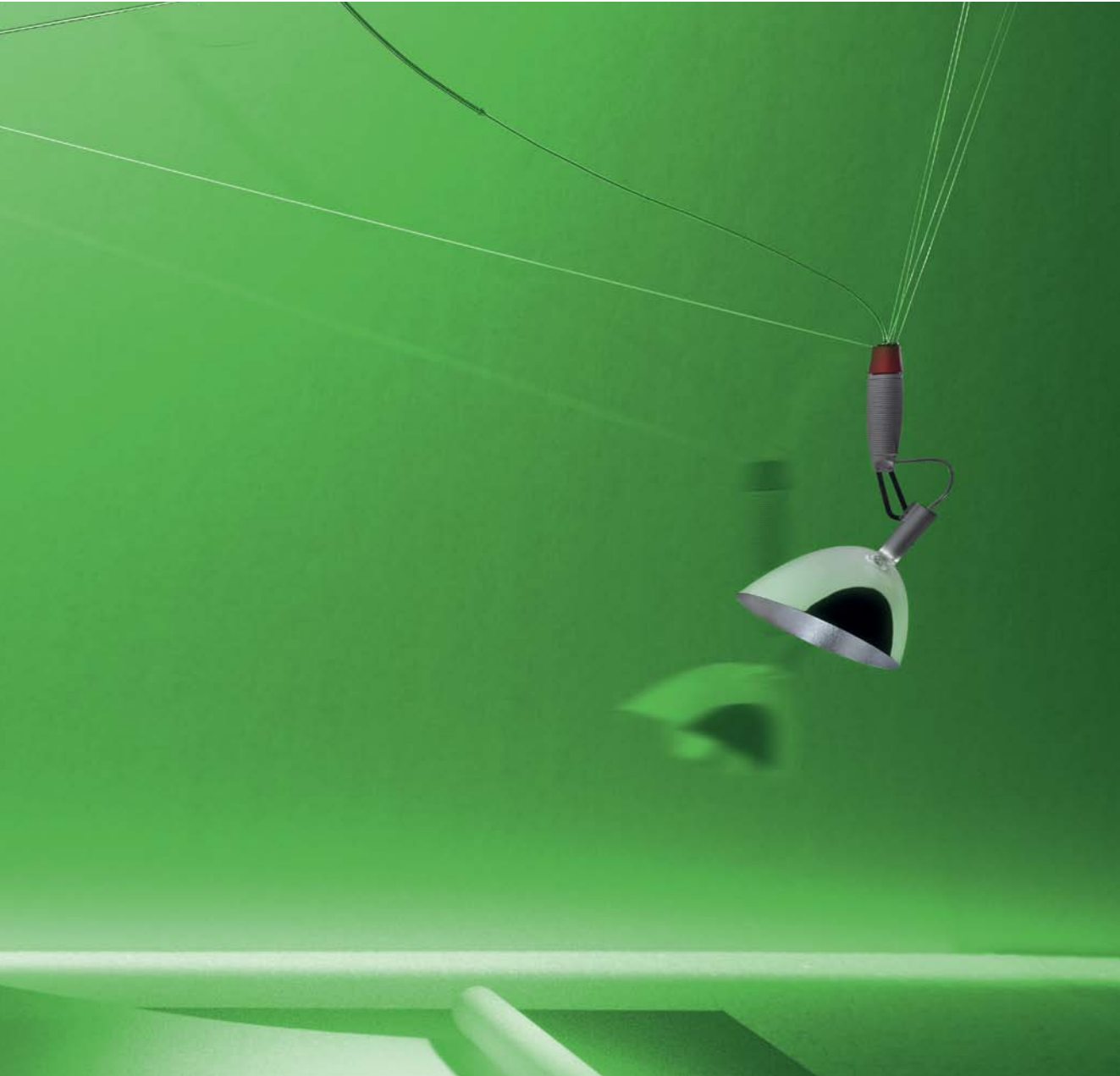
Öff Öff Ingo Maurer und Team 1996

Porzellan glasiert, Metall. Stufenlos höhenverstellbar. Die Lampe kann in 6 Stufen in ihrer Neigung verstellt werden. Baldachin in Porzellan, Ø 8 cm. Für Raumhöhen bis 300 oder 550 cm. Lieferung mit Leuchtmittel. ■ Glazed porcelain, metal. Height freely adjustable. Tilttable in 6 stages. Porcelain canopy Ø 8 cm. For ceiling heights up to 300 or 550 cm. Complete with bulb. ■ Porcelaine glacée, métal. Réglage en hauteur sans graduation. Inclinaison en 6 graduations. Baldaquin Ø 8 cm en porcelaine. Pour hauteurs de plafond jusqu'à 300 ou 550 cm. Livrée avec ampoule. ■ Porcellana vetrificata, metallo. Regolazione continua dell'altezza. L'inclinazione della lampada è regolabile in sei posizioni prefissate. Rosone Ø cm. 8 in porcellana. Per altezze di soffitto fino a cm. 300 o 550. Lampadina inclusa. ■ Porcelana glaseada, metal. Altura regulable sin escalones. La inclinación de la lámpara se puede regular en 6 posiciones. Florón de porcelana con 8 Ø cm. Para alturas de hasta 300 o 550 cm. Suministrada con bombilla.



aTool Christoph Matthias 2003

Aluminium, Edelstahl, Kunststoff. An drei Seilen aufgehängt. Innerhalb der Aufhängepunkte stufenlos höhenverstellbar und in alle Richtungen zu verschieben. Aufhängepunkte nach Wahl. Leuchtenkopf um 360° dreh- und um 45° schwenkbar. Der Reflektor ist außen matt grau lackiert. Lieferung mit Leuchtmittel. ■ Aluminium, stainless steel, plastic. Suspended on three wires. Freely adjustable in height and width within the lamp's suspension points. Free choice of suspension points. Head of lamp rotates through 360° and tilts through 45°. The reflector has a mat grey finish. Complete with bulb. ■ Aluminium, acier inoxydable, matière plastique. Suspendue à trois fils. Hauteur réglable sans graduation entre les points de fixation. Se déplace dans toutes les directions. Points de fixation au choix. Tête de lampe rotative à 360° et orientable à 45°. La face extérieure du réflecteur est vernie en gris mat. Livrée avec ampoule. ■ Alluminio, acciaio inossidabile, materiale sintetico. Sospesa a tre cavi. Regolazione continua dell'altezza entro i punti di fissaggio. Orientabile in tutte le direzioni. Punti di fissaggio a scelta. Il riflettore ruota di 360°, e si inclina di 45°. La superficie esterna del riflettore è verniciata grigio opaco. Lampadina inclusa. ■ Aluminio, acero inoxidable, plástico. Suspensión por tres cables. Mediante los puntos de sujeción puede ajustarse la altura en forma continua y desplazarse en todas las direcciones libremente. Cabezal de iluminación rotatable a 360° con una oscilación de 45°. El exterior del reflector está pintado en gris mate. Suministrada con bombilla.

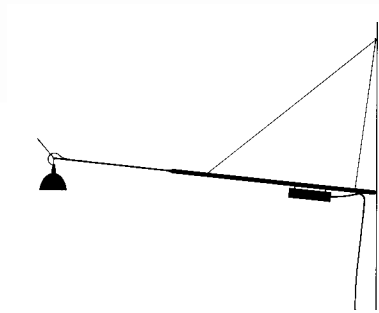
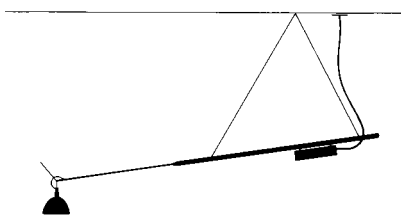


- 40
- min. 80, max. 240

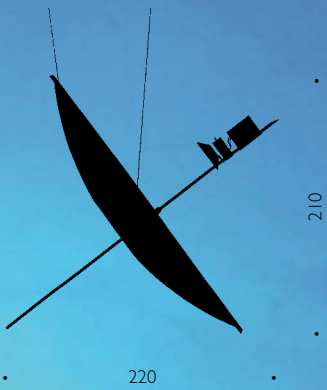


Max. Mover Ingo Maurer und Team 2000

Aluminium, Fiberglas. Das Teleskop ist von 110 auf 210 cm ausziehbar. Durch die Aufhängung an Nylonseilen ist Max. Mover in der Höhe zu verstellen und um 180° drehbar. An seinem Griff kann der Reflektor in zwei Richtungen stufenlos eingerichtet werden. Lieferung mit Leuchtmittel. ■ Aluminium, fibreglass. The telescopic arm extends from 110 to 210 cm, the nylon suspension wires allow for height adjustment and the lamp can be rotated through 180°. The reflector is freely adjustable in two directions, using the handle. Complete with bulb. ■ Aluminium, fibre de verre. Le télescope est extensible de 110 à 210 cm. Suspendu à des fils de nylon, Max. Mover est réglable en hauteur et rotatif à 180°. Grâce à sa poignée, le réflecteur peut être réglé sans graduation dans deux directions. Livrée avec ampoule. ■ Alluminio, vetroresina. Il braccio telescopico è allungabile da cm. 110 a cm. 210. Essendo sospesa a fili di nylon, Max. Mover è regolabile in altezza e ruota di 180°. Agendo sulla leva, il riflettore può essere regolato in continuo in due direzioni. Lampadina inclusa. ■ Aluminio, fibra de vidrio. El telescopio se puede estirar entre los 110 cm y los 210 cm. La altura de la lámpara Max.Mover se puede regular en todo lo largo de los hilos de nylon de los que cuelga y se puede girar 180°. El reflector se puede ajustar en dos direcciones sin escalones. Suministrada con bombilla.



• 110-210 •





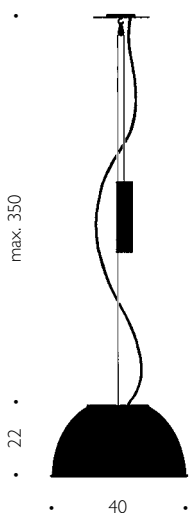
Living Vegas Ingo Maurer 2007

5 Neon-Röhren in Rot, Blau und Weiß. Kunststoff, Metall verchromt, Aluminiumblech. Mit elektronischem Vorschaltgerät. Für Raumhöhen bis 350 cm. Sonderlängen auf Anfrage. ■ 5 neon tubes in red, blue and white. Plastic, chrome-plated metal, aluminium. With electronic ballast. For ceiling heights up to 350 cm. Special lengths on request. ■ 5 tubes au néon en rouge, bleu et blanc. Matière plastique, métal chromé, aluminium. Avec ballast électronique. Pour hauteurs de pièce jusqu'à 350 cm. Longueur spéciale sur demande. ■ 5 tubi al neon in rosso, blu e bianco. Materiale sintetico, metallo cromato, alluminio. Con alimentatore elettronico. Per soffitti con altezze fino a 350 cm. Lunghezze speciali su richiesta. ■ 5 tubos luminosos en rojo, azul y blanco. Plástico, metal cromado, chapa de aluminio. Con balastro electrónico. Para alturas de hasta 350 cm. Largo especial a petición.



Kabokov Ingo Maurer 1993

Innen verspiegelter Glasreflektor, Gegengewicht aus Edelstahl. Metallbaldachin Ø 13 cm, mit Umlenkrolle, Keramikfassung. Gesamtgewicht ca. 11 kg. Stufenlos höhenverstellbar. Für Raumhöhen bis 470 cm. Lieferung ohne Leuchtmittel. ■ Glass reflector with polished inner surface, counterweight in stainless steel. Metal canopy Ø 13 cm with pulley, ceramic socket. Total weight approx. 11 kg. Height continuously adjustable. For ceiling heights up to 470 cm. Bulb not included. ■ Réflecteur en verre, intérieur miroitant. Contrepoids en acier inoxydable. Baldaquin Ø 13 cm en métal avec poulie de renvoi, douille en céramique. Poids total: environ 11 kg. Réglable en hauteur sans graduation. Pour des hauteurs de plafond jusqu'à 470 cm. Livrée sans ampoule. ■ Riflettore in vetro specchiato all'interno, contrappeso in acciaio inossidabile. Rosone in metallo Ø cm. 13 con carrucola per regolazione continua dell'altezza. Portalampada in ceramica. Peso complessivo ca. kg. 11. Per soffitti con altezza fino a cm. 470. Lampadina non inclusa. ■ Reflector con espejado interno, contrapeso de acero fino. Florón de metal Ø 13 cm con polea, portalámpara de cerámica. Peso total aprox. 11 kg. Ajuste de altura gradual. Para ambientes con altura de hasta 470 cm. Suministrada sin bombilla.





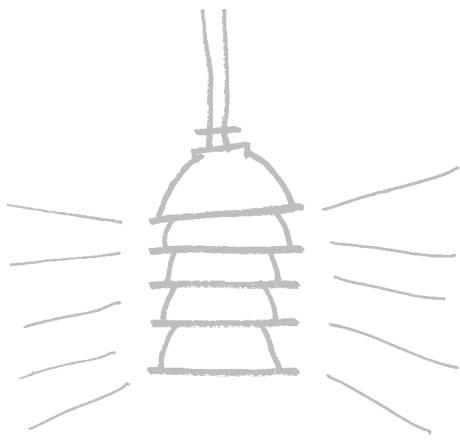
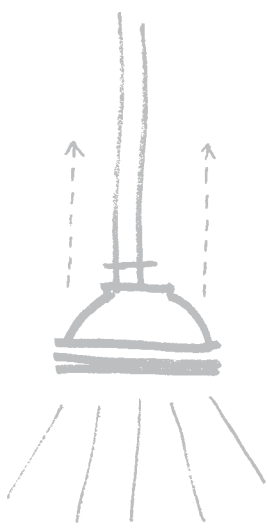
Savoie Donato Savoie, Ingo Maurer 1979

Baldachin und Fassung aus weißem Porzellan. Silikon-Kabel. Glühlampe halb mattiert. Höhenverstellbar bis maximal 180 cm. Version 230 Volt mit Leuchtmittel. ■ Canopy and socket in white porcelain. Silicone cable. Bulb semi-frosted. Height adjustable (max. 180 cm), 230 volts version complete with bulb. ■ Baldaquin et douille en porcelaine blanche. Câble en silicone. Ampoule 60 demi-dépolie. Hauteur réglable jusqu'à une longueur de 180 cm au maximum. Version 230 volts livrée avec ampoule. ■ Rosone e portalampada in porcellana bianca. Cavo in silicone. Lampadina semi-opalizzata. Regolabile in altezza fino a una lunghezza massima di cm. 180. Versione 230 volt fornita con lampadina. ■ Florón y portalámpara de porcelana blanca. Cable de silicona. Bombilla vatios mate. Altura ajustable hasta un máximo de 180 cm. Versión 230 voltios con bombillas.



Five Pack Axel Schmid 2007

Stahl. Fünf Reflektoren außen matt weiß, innen gelb bzw. weiß lackiert. Lichteffect durch Verstellen des Abstands der Reflektoren variabel. Für Raumhöhen bis 300 cm. Sonderlängen auf Anfrage. Lieferung mit Leuchtmitteln. ■ Steel. Five reflectors exterior mat white, interior yellow respectively white lacquer. Light effect variable by adjusting the spacing between the reflectors. For ceiling heights up to 300 cm. Alternative lengths available on request. Complete with bulbs. ■ Acier. Cinq réflecteurs: extérieur vernis blanc mat, intérieur vernis jaune et blanc. Effet lumineux variable pour régler la distance entre les réflecteurs. Pour hauteurs de pièce jusqu'à 300 cm. Longueurs spéciales sur demande. Livrée avec ampoules. ■ Acciaio. Cinque riflettori superficie esterna verniciata bianca opaca, superficie interna verniciata giallo e bianco. Regolando i riflettori varia l'atmosfera luminosa. Per soffitti con altezze fino a 300 cm. Lunghezze speciali su richiesta. Lampadine incluse. ■ Acero. Cinco pantallas reflectoras con exterior blanco mate, interior amarillo o bien pintado en blanco. Efecto variable de luz según la distancia entre las pantallas reflectoras. Apto para alturas de hasta 300 cm. Longitudes especiales por encargo. Suministrada con bombillas.

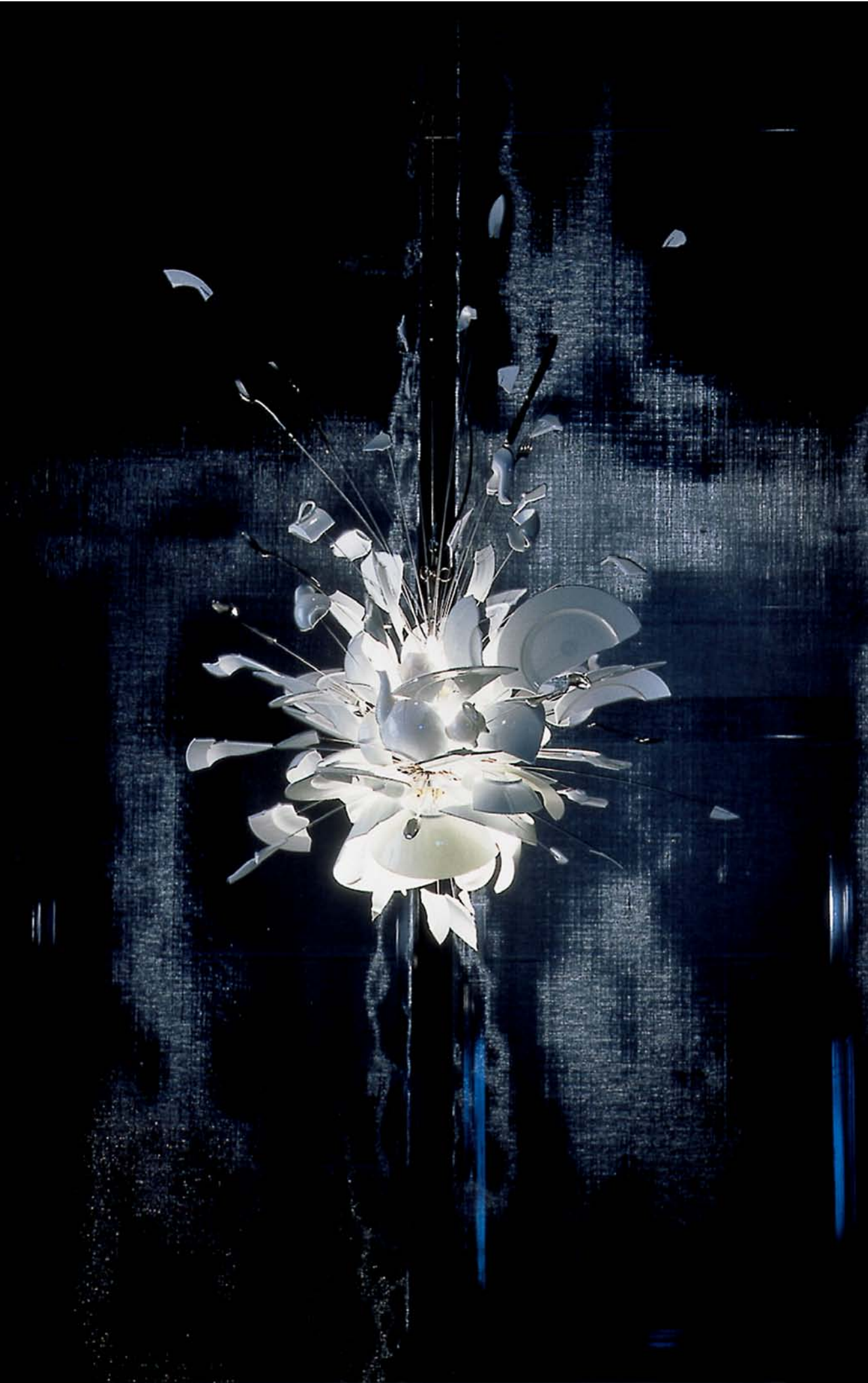




Fly Candle Fly! Georg Baldele und Team 1996

Wachskerze mit Aufhängeseil, 3 m Verlängerung und Tropfenfänger. Länge 30 cm. Brenndauer ca. 20 Stunden. ■ Wax candle with suspension wire, 3 m extension and dripcatcher. Length 30 cm. Burns for approx. 20 hours. ■ Bougie de cire avec câble de suspension, 3 m de rallonge et attrape-gouttes. Longueur 30 cm. Durée de combustion env. 20 heures. ■ Candela in cera con filo di sospensione, filo di prolungamento di m. 3 e raccoglitore di gocce. Lunghezza cm. 30. Durata ca. 20 ore. ■ Vela de cera de 30 cm de largo con cable de sujeción de 3 m y soporte que evita el goteo de la cera. Duración de la combustión, aprox. 20 horas.

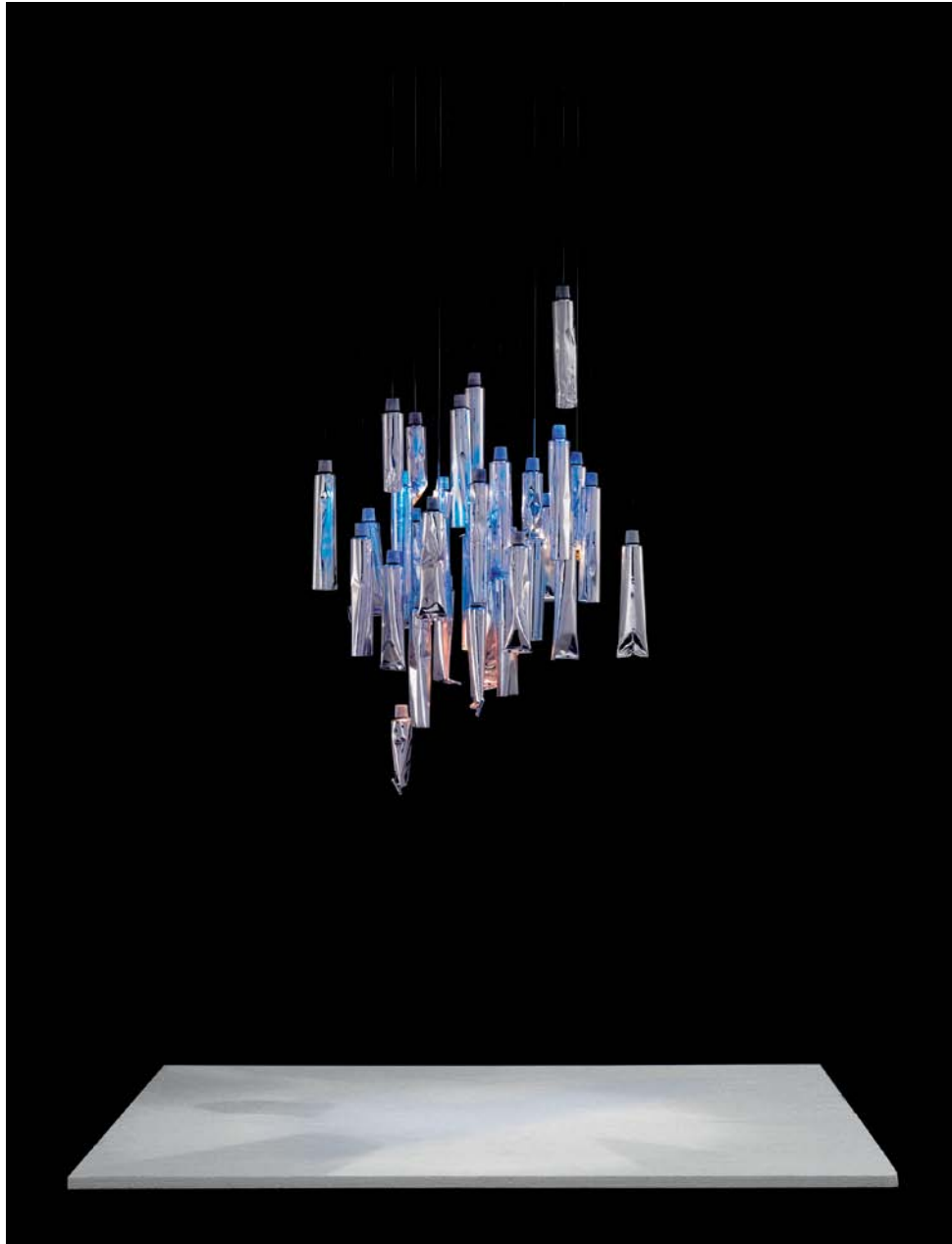






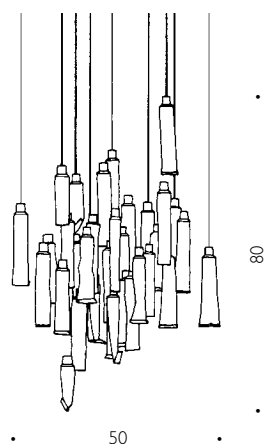
Porca Miseria! *Ingo Maurer 1994*

Limitierte Produktion. Nähere Angaben auf Anfrage. ■ Limited production. Please contact us for more detailed information. ■ Production limitée. Indications plus détaillées sur demande. ■ Produzione limitata. Informazioni dettagliate su richiesta. ■ Producción limitada. Para más información, por favor no duden en contactar con nosotros.



Tu-Be I Ingo Maurer, Ron Arad 2007

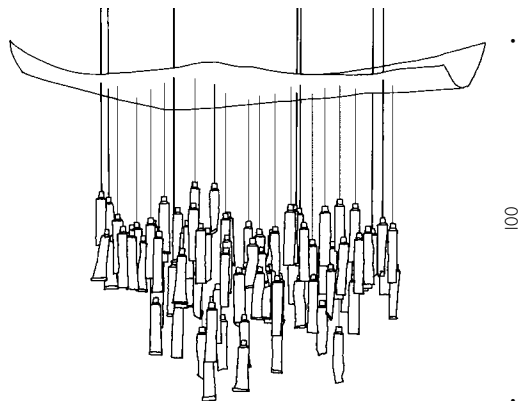
36 Aluminium-Tuben, Stahl, Kunststoff. Für Raumhöhen bis 350 cm. Lieferung mit Leuchtmitteln und zwei Ersatztuben. ■ 36 aluminium tubes, steel, plastic. For ceiling heights up to 350 cm. Complete with bulbs and 2 spare tubes. ■ 36 tubes d'aluminium, acier, matière plastique. Pour hauteurs de pièce jusqu'à 350 cm. Livrée avec ampoules et deux tubes de remplacement. ■ 36 tubi in alluminio, acciaio, materiale sintetico. Per soffitti con altezze fino a 350 cm. Lampadine e 2 tubi di ricambio inclusi. ■ 36 tubos de aluminio, acero, plástico. Para estancias de altura hasta 350 cm. Suministrada con bombillas y 2 tubos adicionales de recambio.





Tu-Be Lüster *Ingo Maurer, Ron Arad 2007*

93 Aluminium-Tuben, Stahl, Kunststoff. Für Raumhöhen bis 350 cm. Lieferung mit Leuchtmitteln und drei Ersatztuben. ■ 93 aluminium tubes, steel, plastic. For ceiling heights up to 350 cm. Complete with bulbs and 3 spare tubes. ■ 93 tubes d'aluminium, acier, matière plastique. Pour hauteurs de pièce jusqu'à 350 cm. Livrée avec ampoules et trois tubes de remplacement. ■ 93 tubi in alluminio, acciaio, materiale sintetico. Per soffitti con altezze fino a 350 cm. Lampadine e 3 tubi di ricambio inclusi. ■ 93 tubos de aluminio, acero, plástico. Para estancias de altura hasta 350 cm. Suministrada con bombillas y 3 tubos adicionales de recambio.



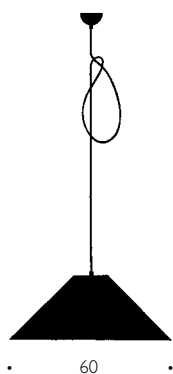
140



Knitterling Ingo Maurer 1978

Japanisches Papier, schwarzer Kunststoffbaldachin Ø 8 cm. Lieferung ohne Glühlampe, empfohlen: 60 Watt matt. ■ Japanese paper, black plastic canopy Ø 8 cm. Recommended choice of bulb (not included): 60 watts, frosted. ■ Papier japonais, baldachin en plastique noir Ø 8 cm. Livrée sans ampoule, ampoule dépolie de 60 watts recommandée. ■ Carta giapponese, rosone in materiale sintetico nero Ø cm. 8. Lampadina non inclusa. Consigliato l'impiego di una lampadina opaca da 60 watt. ■ Papel japonés, florón de plástico negro Ø 8 cm. Suministrada sin bombilla, recomendamos: 60 vatios mate.

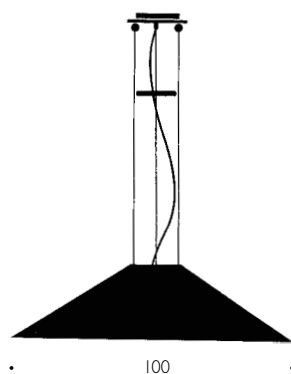
Alternative available with paper cover from below. See Maru.



• 24 •

Knitterling

• 60 •



• 26 •

Maru

• 100 •



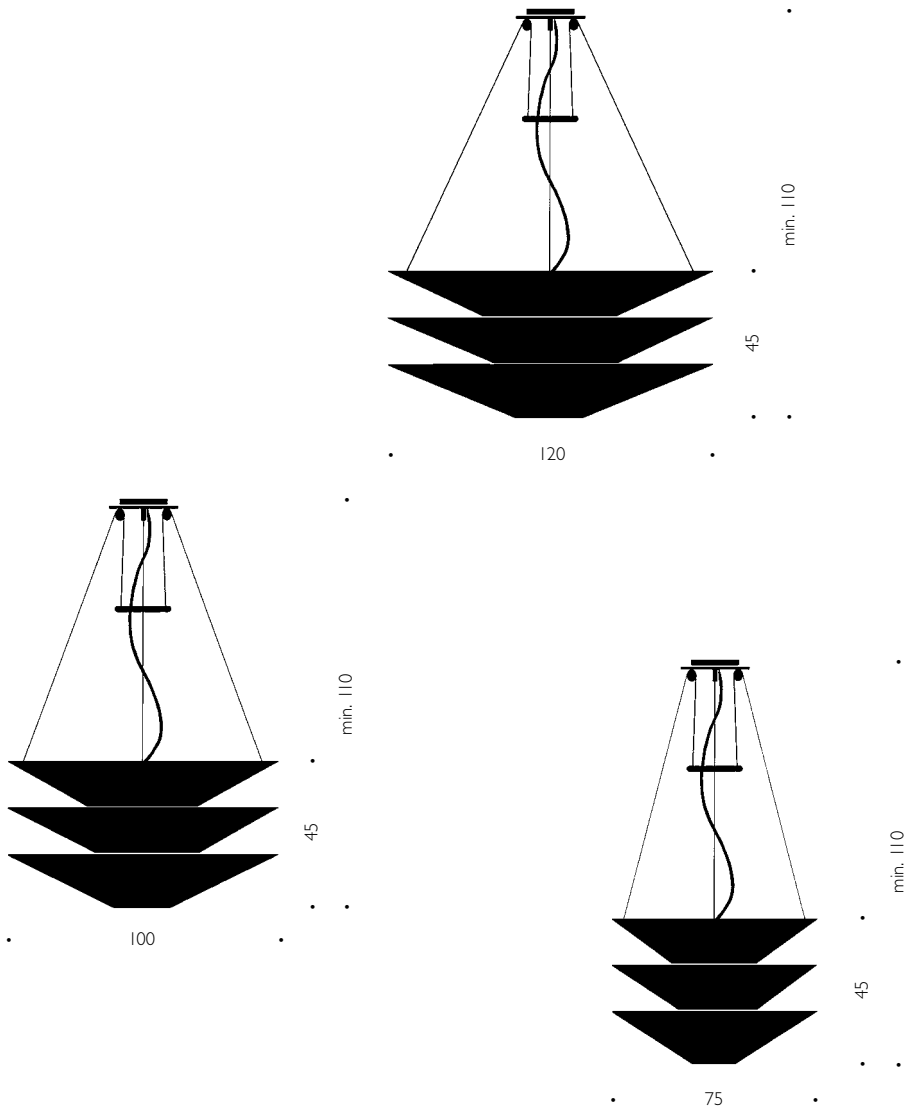
Maru Ingo Maurer 1980

Schirm aus japanischem Papier, aufgehängt an drei dünnen Metallseilen, roter Eisenring für Höhenverstellung (Gegengewicht). Baldachin weiß lackiertes Metall Ø 22 cm. Lieferung ohne Glühlampe. Als gewolltes gestalterisches Element ist das Papier von Maru verknittert. ■ Japanese paper shade, suspended on three thin metal cables. Height adjustable with red iron ring, which serves as a counterweight. Metal canopy, white finish Ø 22 cm. The paper of Maru is crinkled. This is an intended design attribute. ■ Abat-jour en papier japonais, suspendu par trois câbles fins en métal, anneau en fer rouge pour régler la hauteur (contrepois). Baldaquin en métal laqué blanc Ø 22 cm. Livrée sans ampoule. Le papier pour Maru est froissé, ainsi voulu comme effet de style. ■ Paralume in carta giapponese, sostenuto da tre sottili fili metallici, anello rosso in ferro per la regolazione dell'altezza (contrappeso). Rosone in metallo verniciato bianco Ø cm. 22. Lampadina non inclusa. Una caratteristica voluta del design di Maru è l'effetto sgualcito della carta. ■ Sombrilla de papel japonés colgante de tres finos hilos de metal, con anillo rojo de hierro para ajustar la altura (a contra peso). Florón de metal lacado en blanco Ø 22 cm. Suministrada sin bombilla. El papel de la lámpara Maru está arrugado intencionadamente como parte de su diseño.





Available in three sizes.



Floatation Ingo Maurer 1980

Drei Schirme aus japanischem Papier, aufgehängt an dünnen Metallseilen, roter Eisenring für Höhenverstellung (Gegengewicht), Baldachin weiß lackiertes Metall Ø 22 cm. Lieferung ohne Glühlampen. Die Schirme können einzeln ausgetauscht werden. ■ Three Japanese paper shades, suspended on thin metal cables. Height adjustable with red enamelled iron ring, which serves as a counterweight. Metal canopy, white finish Ø 22 cm. Bulbs not included. Shades separately replaceable. ■ Trois éléments abat-jour en papier japonais suspendus par des câbles fins en métal, anneau rouge en fer pour régler la hauteur (contrepois), baldachin en métal laqué blanc Ø 22 cm. Livrée sans ampoules. Les abat-jour peuvent être remplacés séparément. ■ Tre paralumi in carta giapponese, sostenuti da sottili fili metallici, anello rosso in ferro per la regolazione dell'altezza (contrappeso), rosone in metallo verniciato bianco Ø cm. 22. Lampadine non incluse. I paralumi possono essere sostituiti singolarmente. ■ Tres pantallas de papel japonés, colgadas de finos cables de metal, aro rojo de metal para el ajuste su altura (contrapeso), florón de metal pintado de blanco Ø 22 cm. Suministrada sin bombillas. Las pantallas pueden ser recambiadas individualmente.



In a world of throwaways and built-in obsolescence, we remain steadfast in our commitment to singular design and production by hand. It is with thousands of parts and by human hands that we bring our special products to light.

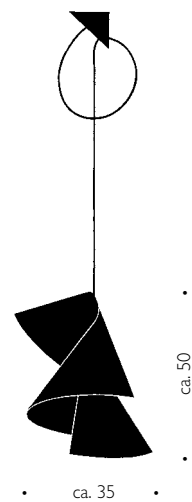
Das Papier von Floatation, Knitterling, Maru und der Tischlampe Lampampe ist als gewolltes, gestalterisches Element verknittert. Es reagiert auf Schwankungen der Luftfeuchtigkeit. Dadurch kann sich die Spannung der Schirme verändern. Diese Lampen sind nicht geeignet für Räume mit hoher Luftfeuchtigkeit.

The paper of Floatation, Knitterling, Maru and the table lamp Lampampe is crinkled. This is an intended design attribute. The material reacts to fluctuations from humidity. Therefore, changes in the rigidity of the shades can not be prevented. These lamps are not suited for environments with high humidity.

Le papier pour Floatation, Knitterling, Maru et la lampe de table Lampampe est froissé, ainsi voulu comme effet de style. Le matériel très sensible réagit à l'humidité ambiante. Aussi le papier peut légèrement se détendre. Ces produits ne sont pas appropriés pour des pièces avec un fort taux d'humidité.

Una caratteristica voluta del design di Floatation, Knitterling, Maru e della lampada da tavolo Lampampe è l'effetto sgualcito della carta. Il materiale reagisce a oscillazioni dell'umidità. Modifiche della tensione della carta non sono, perciò, escluse. Questi prodotti non sono adatti all'uso in ambienti ad alta umidità.

El papel de Floatation, Knitterling, Maru y la lámpara de mesa Lampampe está arrugado intencionadamente como parte de su diseño. El material compuesto de elementos naturales reacciona ante variaciones de la humedad. Por este motivo puede variar la tirantez del papel. Estas lámparas no están recomendadas para espacios con un alto porcentaje de humedad.



Willydilly Ingo Maurer 1983

Weißer transluzenter Karton. Kunststoff-Baldachin Ø 9 cm weiß, fluoreszierende Halteklammer. Höhenverstellbar. Schirmform und -größe variabel. Lieferung ohne Glühlampe.

■ White translucent cardboard. Plastic canopy Ø 9 cm white, with fluorescent clip. Height adjustable. Shape and size of shade can be varied as required. Bulb not included.

■ Carton blanc translucide. Baldaquin en plastique Ø 9 cm blanc, pince fluorescente.

Hauteur réglable. Forme et dimension de l'abat-jour variables. Livrée sans ampoule. ■

Cartone bianco traslucido, rosone Ø cm. 9 bianco in materiale sintetico, molletta fluorescente. Altezza regolabile. Forma e dimensione del paralume varabili. Lampadina non inclusa. ■

Cartón blanco translúcido. Florón de plástico blanco Ø 9 cm pinzas fluorescentes de sujeción. Altura ajustable. La forma en espiral de la pantalla de cartón se puede adaptar. Suministrada sin bombilla.



Grasl Jan Roth 1973

Reflektor aus glanzeloxiertem Aluminium und Messing. Kabel mit Schalter und Stecker. Lieferung mit Glühlampe. Auch als Tischlampe. ■ Reflector: anodized aluminium, brass. Cable with switch and plug. Complete with bulb. Also available as table lamp. ■ Réflecteur en aluminium électrolysé et laiton. Câble avec interrupteur et prise de courant. Livrée avec ampoule. Egalement disponible comme lampe de table. ■ Riflettore in alluminio anodizzato e ottone. Cavo con interruttore e spina. Lampadina inclusa. Disponibile anche nella versione da tavolo. ■ Reflector de aluminio anodizado y latón. Cable con interruptor y enchufe. Suministrada con bombilla. También como lámpara de sobremesa.



Grasl Vulgaris Jan Roth 1973

Geriffelter Reflektor aus Aluminium. Kabel mit Schalter und Stecker. Lieferung mit Glühlampe. Auch als Tischlampe. ■ Reflector: aluminium with "corrugated" surface. Cable with switch and plug. Complete with bulb. Also available as table lamp. ■ Réflecteur façon «tôle ondulée» en aluminium. Câble avec interrupteur et prise de courant. Livrée avec ampoule. Egalement disponible comme lampe de table. ■ Riflettore in alluminio ondulato. Cavo con interruttore e spina. Lampadina inclusa. Disponibile anche nella versione da tavolo. ■ Reflector estriado de aluminio. Cable con interruptor y enchufe. Suministrada con bombilla. También como lámpara de sobremesa.



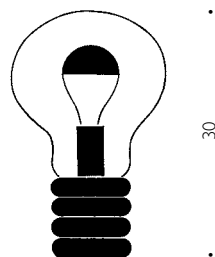
Tischlampen / Table lamps / Lampes de table / Lampade da tavolo / Lámparas de sobremesa





Bulb Ingo Maurer 1966

Hochglanzverchromtes Metall, mundgeblasenes Kristallglas. Lieferung mit kuppenverspiegelter Glühlampe. ■ Polished chromium-plated metal base, hand-blown crystal glass. Complete with top-chromated bulb. ■ Métal chromée, cristal soufflé. Livrée avec ampoule à coupole argentée. ■ Metallo cromato lucido, cristallo soffiato. Lampadina a cupola argentata inclusa. ■ Metal cromado brillante, cristal soplado artesanalmente. Suministrada con bombilla metalizada.



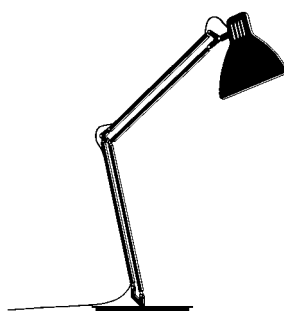
 max. 100 W E27

20



Looksoflat *Stefan Geisbauer 2010*

Aluminium. Schalter am Leuchtenkopf. Erhältlich in Aluminium natur oder Schwarz. Mit Steckernetzteil. Lieferung mit Leuchtmittel. ■ Aluminium. Toggle switch integrated in lamp head. Colour aluminium or black. Plug with integrated power supply. Complete with bulb. ■ Aluminium. Interrupteur à bascule intégré à la tête de la lampe. Couleur aluminium ou noir. Avec ballast électronique. Livrée avec ampoule. ■ Alluminio. Interruttore integrato nella testa della lampada. Colore alluminio o nero. Con alimentatore. Lampadina inclusa. ■ Aluminio. Interruptor en la cabeza de la lámpara. Disponible en aluminio o negro. Con fuente de alimentación eléctrica. Suministrada con bombilla.



44-70





At some point, someone decided that the frosted light bulb was our enemy, inefficient, and a hazard to the environment, so they lobbied to banish its beauty into extinction.

Disgusted with the alternatives we created a new efficient bulb technology – an innovative 24 V halogen which thumbs its nose at the new legislation. Greener than its predecessor, it possesses the same frosty white light we have known and loved, and it is coming to a reality near you, sooner than you think. In fact it's already shipping. Be happy, the future is warm, bright, and friendlier than ever. You can thank us later.

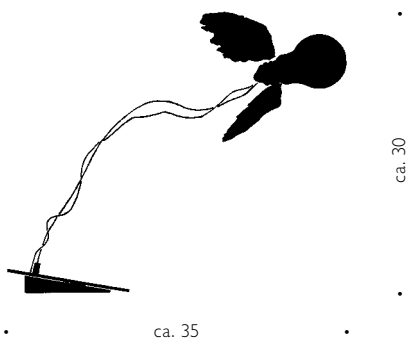
Ingo Maurer und Team 2009



Lucellino Ingo Maurer 1992

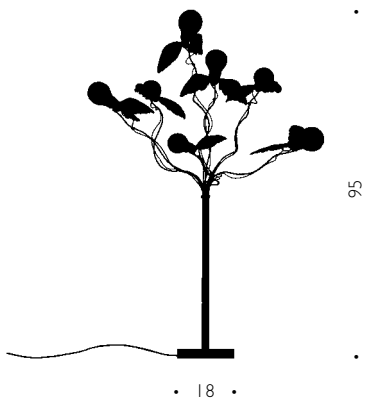
Glas, Messing, Kunststoff, handgefertigte Flügel aus Gänsefedern. Lieferung mit Ersatzglühlampe. Nicht geeignet für Räume mit hoher Luftfeuchtigkeit. ■ Glass, brass, plastic, hand-crafted goosefeather wings. Complete with spare bulb. Not suited for rooms with high humidity. ■ Verre, laiton, matière plastique, ailes confectionnées à la main en plumes d'oie. Livrée avec une ampoule de rechange. N'est pas appropriée pour des pièces avec un fort taux humidité. ■ Vetro, ottone, materiale sintetico, ali in piume d'oca lavorate a mano. Fornita con lampadina di ricambio. Non adatta all'uso in ambienti ad alta umidità. ■ Vidrio, latón, plástico, alas hechas a mano con plumas de oca. Suministrada con bombilla de recambio. No apta para ambientes con un alto porcentaje de humedad.

24V Halogen EU approved



ca. 30

ca. 35



Birdie's Busch Ingo Maurer und Team 2010

Metall, Flügel aus Gänsefedern. Sieben Niedervolt-Glühlampen, transparente Kabel. Kabel mit Schalter, nicht dimmbar. Transformator im Lampenfuß integriert. Lieferung mit zwei Ersatzglühlampen. ■ Metal, goose-feather wings. Seven low-voltage bulbs, transparent cables. Cable with switch, not dimmable. Transformer integrated into base. Complete with bulbs plus two spares. ■ Métal, ailes en plumes d'oie, sept ampoules à bas voltage, câbles transparents. Câble avec interrupteur, non dimmable. Transformateur intégré dans le pied. Livrée avec deux ampoules de rechange. ■ Metallo, ali in piume d'oca, sette lampadine a basso voltaggio, cavi trasparenti. Cavo con interruttore, non dimmerabile. Trasformatore integrato nella base. Insieme due lampadine di ricambio. ■ Metal, alas de plumas de oca, siete bombillas de bajo voltaje, cables transparentes. Cable con interruptor, no regulable en intensidad. Transformador integrado en el pie de lámpara. Suministrada con dos bombillas de recambio.

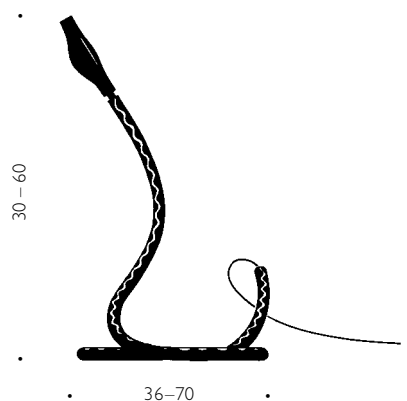
24V Halogen EU approved





Alizz T. Cooper Ingo Maurer und Team 2008

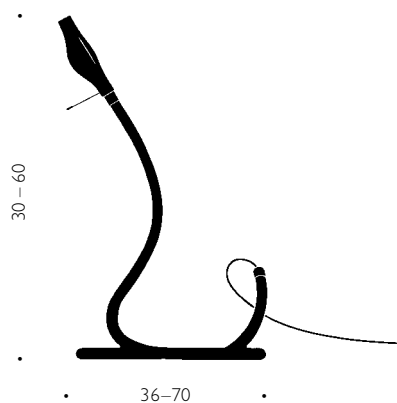
Metall, Kunststoff, flexibler Gummischlauch. Kabel mit Schalter. Reflektor 360° um das Leuchtmittel drehbar. Lieferung mit Leuchtmittel. ■ Metal, plastic, flexible rubber hose. Cable with switch. Reflector rotates through 360° around the bulb. Complete with bulb. ■ Métal, matière plastique, tuyau en caoutchouc flexible. Câble avec interrupteur. Réflecteur rotatif de 360° autour de l'ampoule. Livrée avec ampoule. ■ Metallo, materiale sintetico, tubo di gomma flessibile. Cavo con interruttore. Riflettore rotante di 360° intorno alla lampadina. Lampadina inclusa. ■ Metal, plástico, manguera de caucho. Cable con interruptor. Reflector giratorio alrededor de la bombilla hasta 360°. Suministrada con bombilla.

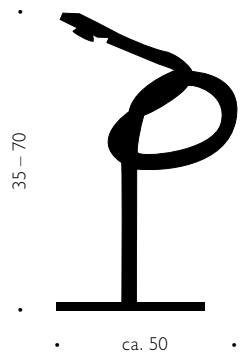




Metall T. Cooper Ingo Maurer und Team 2009

Metall, Kunststoff, Kabel mit Schalter. Reflektor 360° um das Leuchtmittel drehbar. Lieferung mit Leuchtmittel. ■ Metal, plastic, cable with switch. Reflector rotates through 360° around the bulb. Complete with bulb. ■ Métal, matière plastique, câble avec interrupteur. Réflecteur rotatif de 360° autour de l'ampoule. Livrée avec ampoule. ■ Metallo, materiale sintetico, cavo con interruttore. Riflettore rotante di 360° intorno alla lampadina. Lampadina inclusa. ■ Metal, plástico, cable con interruptor. Reflector giratorio alrededor de la bombilla hasta 360°. Suministrada con bombilla.





35 - 70

ca. 50



Zufall Ingo Maurer und Team 2008

Silikon, schwarzes Corian, Aluminium. Der Silikonarm kann flexibel geformt werden. Eingebauter Kippschalter im Lampenfuss. Mit Steckertransformator. ■ Silicone, black Corian, aluminium. The silicone arm can be formed flexibly. Base plate with integrated toggle switch. With transformer. ■ Silicone, Corian noir, aluminium. La forme du tuyau flexible en silicone peut être modifiée. Plaque de base avec interrupteur à bascule intégré. Livrée avec transformateur. ■ Silicone, Corian nero, alluminio. Il braccio in silicone flessibile può essere modellato a piacere. Piastra di base con interruttore a levetta. Con trasformatore. ■ Silicona, Corian negro, aluminio. Brazo de silicona flexible. Base con interruptor integrado. Incluye transformador.



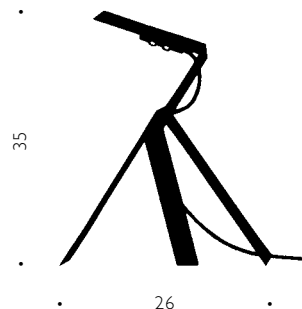
 max. 6 W LED warm white, 2900 K, 320 lm, 12 V

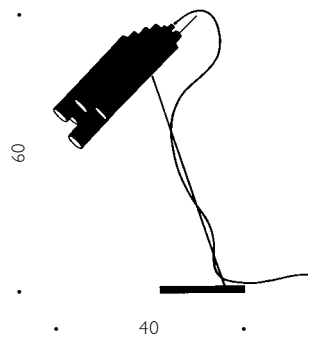


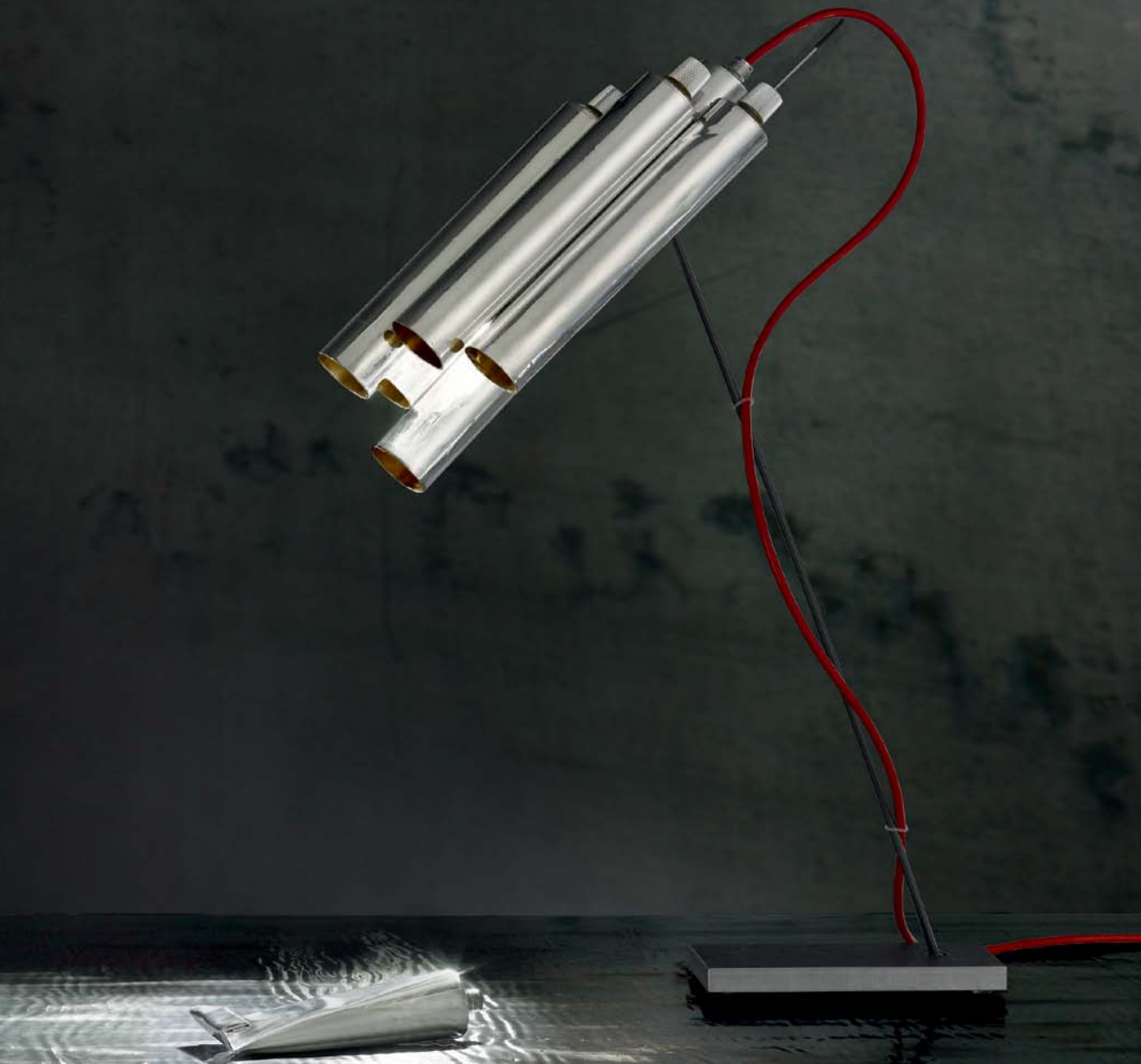


Jetzt Axel Schmid 2009

Eloxiertes Aluminium in Schwarz, Blau oder Orange, Kunststoff. Kabel mit Schalter. ■ Anodized aluminium in black, blue or orange, plastic. Cable with switch. ■ Aluminium anodisé disponible en noir, bleu ou orange, matière plastique. Câble avec interrupteur. ■ Alluminio anodizzato in nero, blu o arancione, materiale sintetico. Cavo con interruttore. ■ Aluminio anodizado en negro, azul ó naranja, plástico. Cable con interruptor.







Tu-Be Two Ingo Maurer 2009

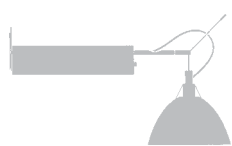
Aluminiumtuben, Stahl. Ein Kugelgelenk in der Fußplatte ermöglicht Drehen und Neigen in jede Richtung. Die Ausrichtung der Tuben ist zusätzlich einstellbar. Lieferung mit Leuchtmittel. ■ Aluminium tubes, steel. The ball-joint makes it possible to turn and tilt the lamp in infinite positions. The angle of the tubes is adjustable. Complete with bulb.

■ Tubes en aluminium, acier. L'articulation à rotule fixée dans la base permet de tourner et d'incliner la lampe dans toutes les directions. L'inclinaison des tubes est de plus ajustable. Livrée avec ampoule ■ Tubi in alluminio, acciaio. La lampada è basculante e rotante in ogni direzione grazie a un giunto a sfera nella piastra base. I tubi possono essere orientati a piacere. Lampadina inclusa. ■ Tubos de aluminio, acero. La articulación de bola de la placa del pie permite girar e inclinar en todas direcciones. Alineación de los tubos ajustable. Suministrada con bombilla.



Max.Kugler Ingo Maurer und Team 2001

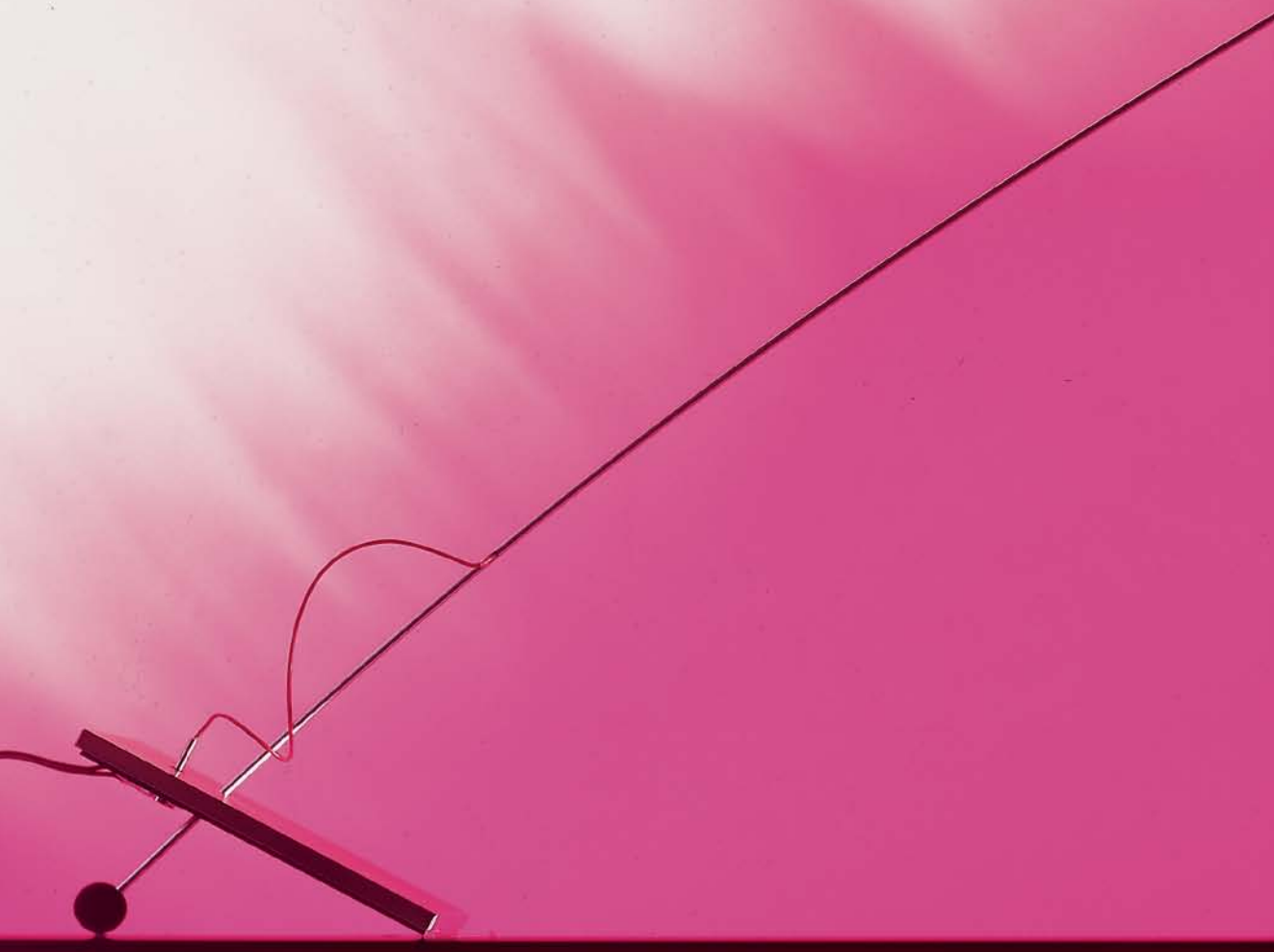
Edelstahl, Aluminium. Das Kugelgelenk ermöglicht stufenloses Drehen und Neigen in alle Richtungen. Der Teleskoparm ist von 60 auf 90 cm ausziehbar. An seinem Griff ist der Reflektor in alle Richtungen schwenkbar. Dimmer mit Schieberegler. Lieferung mit Leuchtmittel. ■ Stainless steel, aluminium. The ball-joint makes it possible to turn and tilt the lamp in all directions. The telescope arm extends from 60 to 90 cm. The reflector (with handle) can be swivelled in any direction. Dimmer with slide control. Complete with bulb. ■ Acier inoxydable, aluminium. L'articulation à rotule permet de tourner et d'incliner la lampe sans graduation dans tous les sens. Le bras télescopique est extensible de 60 à 90 cm. Le réflecteur est orientable dans tous les sens grâce à sa poignée. Avec variateur à curseur. Livrée avec ampoule. ■ Acciaio inossidabile, alluminio. Ruotabile e inclinabile in continuo in tutte le direzioni mediante un giunto sferico. Il braccio telescopico è allungabile da 60 a 90 cm. Agendo sulla leva, il riflettore può essere regolato in tutte le direzioni. Con varialuce lineare. Lampadina inclusa. ■ Acero fino, aluminio. Infinitas posibilidades de rotación y movimiento en todas direcciones gracias a su junta esférica. El brazo telescópico se puede estirar de 60 a 90 cm. Reflector orientable en todas direcciones. Con atenuador. Suministrada con bombilla.



Mozzkito Ingo Maurer und Team 1996

Metall, Kunststoff und Gummi. Mit Kaltlichtspiegellampe. Die Neigung der Lampe kann durch die bewegliche Bodenplatte verändert werden. Reflektor verstellbar. Lieferung mit Leuchtmittel. ■ Metal, plastic and rubber. With cool beam bulb. Position can be modified with movable base-plate. Adjustable reflector. Complete with bulb. ■ Métal, matière plastique et caoutchouc. Avec ampoule à miroir dichroïque. La plaque de base mobile permet de varier l'inclinaison de la lampe. Réflecteur réglable. Livrée avec ampoule. ■ Metallo, materiale sintetico e gomma. Con lampadina dicroica. La piastra di base mobile consente di variare l'inclinazione della lampada. Riflettore regolabile. Lampadina inclusa. ■ Metal, plástico y goma. Con bombilla dicroica. La inclinación de la lámpara se puede cambiar gracias a su base móvil. Reflector regulable. Suministrada con bombilla.

 max. 50 W 60° Halogen GX 5,3  12 V





max 80

80

A blend of raw materials without design constraints.
Simple and free. Unsystematic, yet finished and looks just so,
as if by chance.

Vive l'esprit anarchique.





Prototype Bernhard Dessecker, Ingo Maurer 2001

Aluminium, Edelstahl, Messing, Kunststoff, Silikon. Im Metallfuß um 360° drehbar. Horizontaler Arm um 90° bzw. 80 cm nach oben und unten schwenkbar, Leuchtenkopf um 100° schwenkbar. Reflektor 360° um das Leuchtmittel drehbar. Lieferung mit Leuchtmittel. ■ Aluminium, stainless steel, brass, plastic, silicone. Rotates in metal base through 360°. Horizontal arm can be raised or lowered with 90° (80 cm) radius of travel. Lamp head swivellable through 100°. Reflector rotates through 360° around the bulb. Complete with bulb. ■ Aluminium, acier inoxydable, laiton, matière plastique, silicone. Rotatif à 360° au niveau du pied en métal. Bras horizontal orientable de 90°, et de 80 cm vers le haut ou le bas, tête orientable de 100°. Réflecteur rotatif de 360° autour de l'ampoule. Livrée avec ampoule. ■ Alluminio, acciaio inossidabile, ottone, materiale sintetico, silicone. Rotante di 360° nel piede in metallo. Braccio orizzontale orientabile di 90° e di cm. 80 verso l'alto e verso il basso, testina orientabile di 100°. Riflettore rotante di 360° intorno alla lampadina. Lampadina inclusa. ■ Aluminio, acero fino, latón, plástico, silicón. Pie metálico giratorio hasta 360°. Brazo horizontal orientable hacia arriba y hacia abajo hasta 90° u 80 cm respectivamente. Cabeza de la lámpara inclinable hasta 100°. Reflector giratorio alrededor de la bombilla hasta 360°. Suministrada con bombilla.

 **230 V: max. 75 W I25 V: max. 60 W Halogen G9**





Topolino Bernhard Dessecker 2003

Edelstahl, Kunststoff, Silikon. Steckertransformator mit Schnurschalter. Stab, ca. 20 cm, dreh- und schwenkbar. Schirm um 360° drehbar. Der um 360° drehbare Gummikopf umschließt den Reflektor. Der Stab verbindet den Kopf mit der Klemmplatte und ist durch ein Kugelgelenk schwenkbar. Lieferung mit Leuchtmittel. ■ Stainless steel, plastic, silicone. Plug-in transformer, with switch integrated into cable. Swinging and rotating rod, approx. 20 cm long. Reflector turning 360°. The rubber ball which rotates by 360° degrees embraces the reflector. The rod connects the head and the clamp plate and is articulated by means of a ball joint. Complete with bulb. ■ Acier inoxydable, matière plastique, silicone. Transformateur à prise avec interrupteur sur le câble. Tige, environ 20 cm, orientable et rotative. Abat-jour rotatif à 360°. La tête en caoutchouc, rotative à 360°, entoure le réflecteur. La tige relie la tête à la plaque à pince et est orientable par une articulation à rotule. Livrée avec ampoule. ■ Acciaio inossidabile, materiale sintetico, silicone. Trasformatore a spina con interruttore sul cavo. Asta ca. 20 cm, ruotabile e orientabile. Testina ruotabile di 360°. La testina in gomma ruota di 360°. L'asta collega la testina alla base a morsetto e ruota grazie ad un giunto sferico. Lampadina inclusa. ■ Acero fino, plástico, silicón. Enchufe con transformador y cable con interruptor. Varilla de aprox. 20 cm giratoria e inclinable. Mampara giratoria hasta 360°. La cabeza giratoria hasta 360° protege el reflector. La varilla une la cabeza con la pinza de sujeción y es inclinable gracias a su articulación esférica. Suministrada con bombilla.

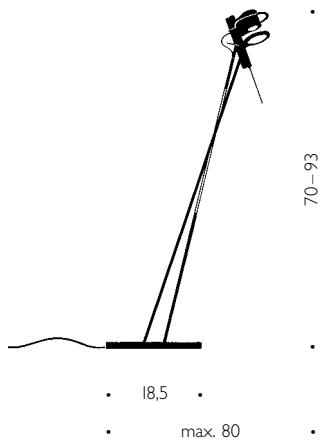


Happy Birthday Jenny



HOT.HOT *Ingo Maurer und Team 2006*

Metall, Glas, schwarz lackierter Stahl. Der Lichtkegel kann durch ein Linsensystem eingestellt werden. Limitierte Edition in Messing erhältlich. Lieferung mit Leuchtmittel. ■ Metal, glass, black lacquered steel. The cone of light is adjustable by a lens system. Limited edition in brass available. Complete with bulb. ■ Métal, verre, acier noir laqué. Le cône lumineux peut être ajusté à l'aide d'un système de lentilles. Edition limitée en laiton disponible. Livrée avec ampoule. ■ Metallo, vetro, acciaio verniciato nero. Il cono di luce può essere regolato mediante un sistema di lenti. Disponibile anche l'edizione limitata in ottone. Lampadina inclusa. ■ Metal, vidrio, acero pintado de negro. El haz de luz puede regularse a través de un sistema de lentes. Edición limitada disponible en latón. Suministrada con bombilla.





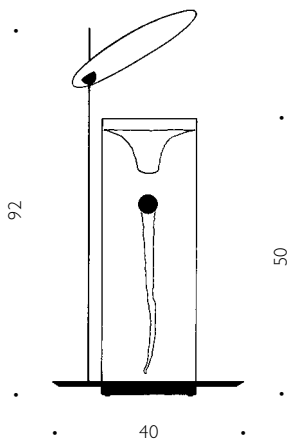
DeliriumYum Ingo Maurer/Sebastian Hepting 2006

Corian, Kristallglas, Spiegel aus Aluminium. Externer Transformator. Interner Motor. Licht und Bewegung des Wassers regulierbar. Tempo und Intervalle der Drehung werden elektronisch gesteuert und können angepasst werden. Mit Kugel, Silberpartikeln, Tabletten zur Wasseraufbereitung und Leuchtmittel. ■ Corian, crystal glass, aluminium mirror. External transformer. Internal motor. Light and movement of water adjustable. Speed and intervals of the rotation are electronically adjustable. Complete with ball, silver particles, tablets for water preparation, and bulb. ■ Corian, cristal, miroir en aluminium. Transformateur externe. Moteur interne. Lumière et mouvement d'eau réglables. Le rythme et l'intervalle de la rotation peuvent être réglés et changés électroniquement. Livrée avec balle, particules d'argent, pastilles pour préparation de l'eau et ampoule. ■ Corian, cristallo, specchio in alluminio. Trasformatore esterno. Motore interno. Intensità della luce e movimento dell'acqua regolabili. La velocità e gli intervalli del movimento rotatorio sono a comando elettronico e possono essere adattati. Con sfera, polverina d'argento, pasticche per la preparazione dell'acqua e lampadina. ■ Corian, cristal, espejo de aluminio. Transformador externo. Motor integrado. Luz y movimiento del agua regulables. La velocidad y los intervalos del movimiento giratorio se controlan y adaptan electrónicamente. Suministrada con bola, partículas de plata, comprimidos para la preparación del agua y bombilla.



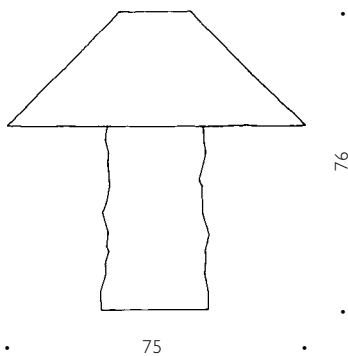
Lampampe Ingo Maurer 1980

Japanisches Papier; Metall. Als gewolltes gestalterisches Element ist das Papier von Lampampe verknittert. Nicht geeignet für Räume mit hoher Luftfeuchtigkeit. Lieferung ohne Glühlampe. ■ Japanese paper, metal. The paper of Lampampe is crinkled. This is an intended design attribute. Not suited for rooms with high humidity. Bulb not included. ■ Papier japonais, métal. Le papier pour Lampampe est froissé, ainsi voulu comme effet de style. N'est pas appropriée pour des pièces avec un fort taux humidité. Livrée sans ampoule. ■ Carta giapponese, metallo. Una caratteristica voluta del design di Lampampe è l'effetto sgualcito della carta. Non adatta all'uso in ambienti ad alta umidità. Lampadina non inclusa. ■ Papel japonés, metal. El papel de la lámpara Lampampe está arrugado intencionadamente como parte del diseño. No indicada para espacios con un alto porcentaje de humedad. Suministrada sin bombilla.



DeliriumYum

max. 35 W Halogen GU4 12V



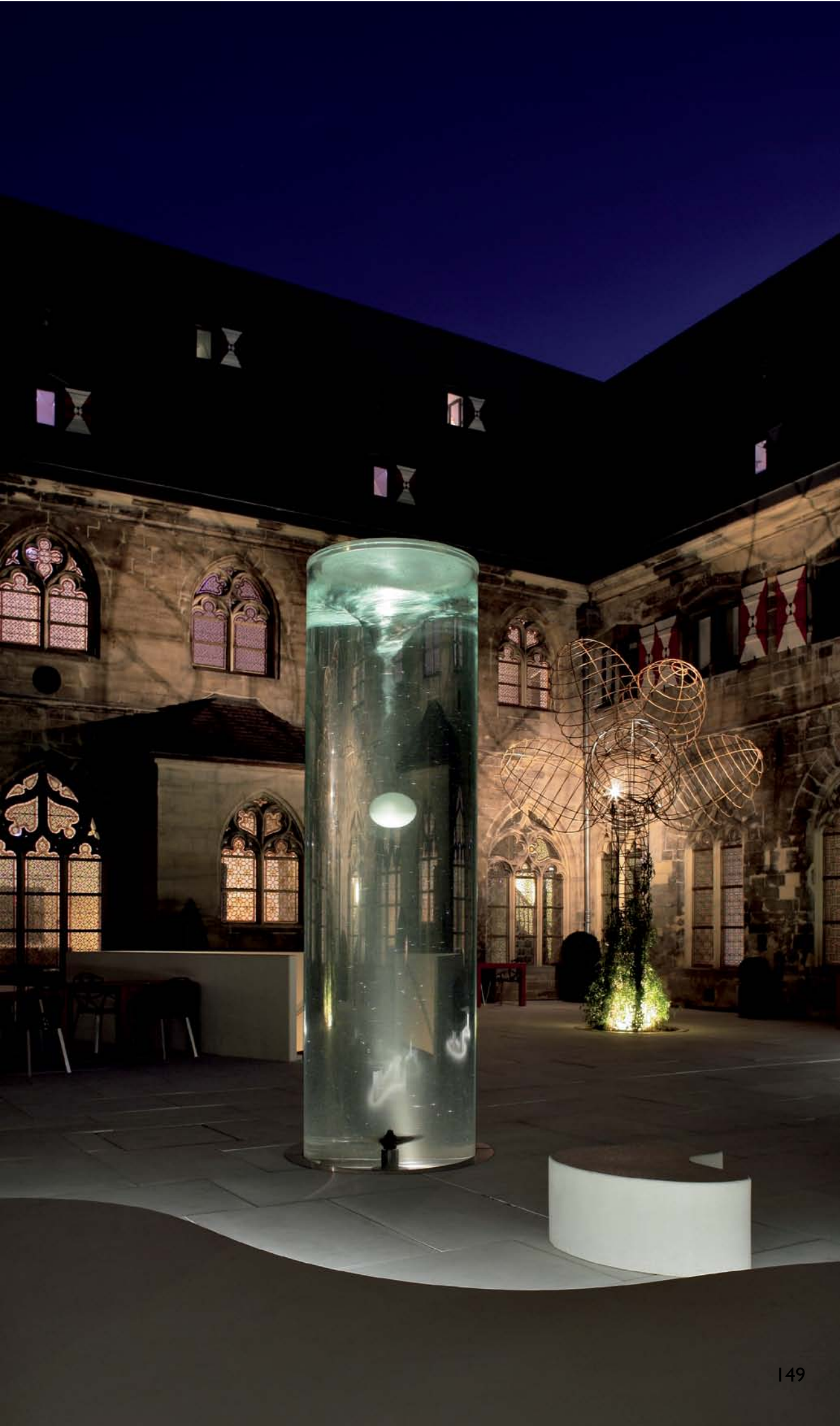
Lampampe

max. 100 W E27

Projects are always a challenge – they give space for the realisation of visions and release new energies which are necessary to accomplish the job.

Our work – both large scale and small scale – ranges from public spaces, landmark buildings to individually commissioned one-of-a-kind creations. Some experimental objects are created purely because it's so tempting to work with new materials.

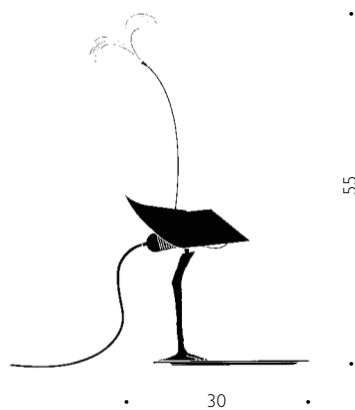
We are always ready to inform you. Please contact us for further information.
info@ingo-maurer.com





Bibibibi Ingo Maurer 1982

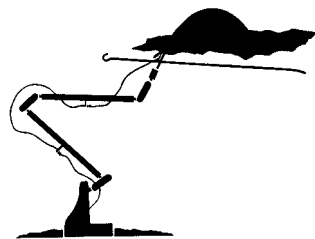
Porzellan, Metall und Plastik. Beweglicher Reflektor. Lieferung mit Glühlampe. ■ Porcelain, metal, plastic. Adjustable reflector. Complete with bulb. ■ Porcelaine, métal et matière plastique. Réflecteur réglable. Livrée avec ampoule. ■ Porcellana, metallo e materiale sintetico. Riflettore orientabile. Lampadina inclusa. ■ Porcelana, metal y plástico. Reflector móvil. Suministrada con bombilla.





Don Quixote Ingo Maurer und Team 1989

Stahl, Aluminium, elastischer Kunststoff. Don Quixote biegt und schwenkt sich, dreht und streckt sich. Lieferung mit Leuchtmittel. ■ Steel, aluminium, flexible plastic. Don Quixote bends, twists, turns and swivels. Complete with bulb. ■ Acier, aluminium, matière plastique élastique. Don Quixote s'incline et pivote, se tourne et s'étire. Livrée avec ampoule. ■ Acciaio, alluminio, materiale sintetico elastico. Don Quixote s'inclina e si gira, ruota e si stende. Lampadina inclusa. ■ Acero, aluminio, plástico elástico. Don Quixote se inclina y oscila, gira y se extiende. Suministrada con bombilla.



ca. 35

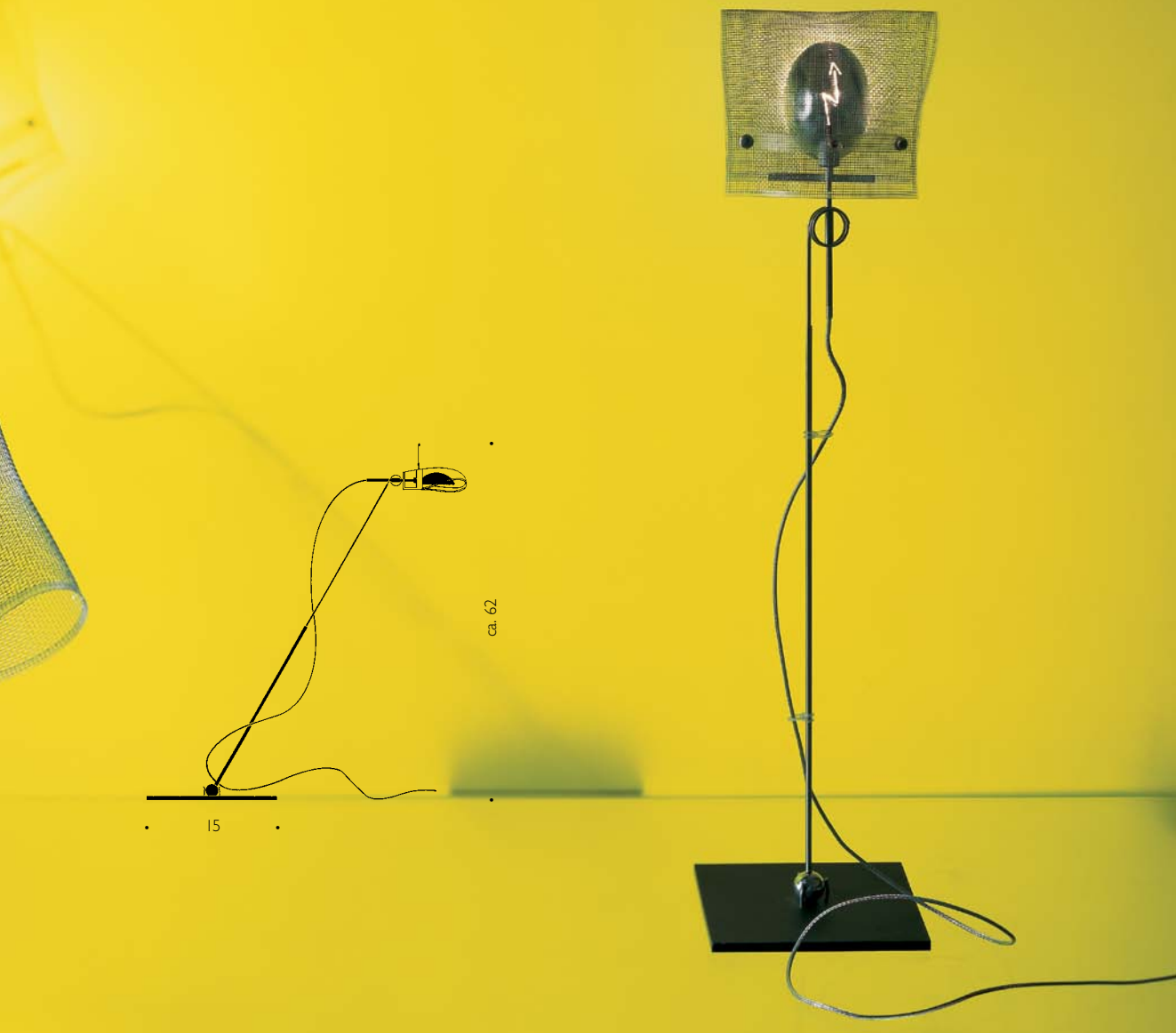


Grasl Jan Roth 1973

Reflektor aus glanzeloxiertem Aluminium und Messing. Kabel mit Schalter und Stecker. Lieferung mit Glühlampe. Auch als Hängelampe. ■ Reflector: anodized aluminium, brass. Cable with switch and plug. Complete with bulb. Also available as hanging lamp. ■ Réflecteur en aluminium électrolysé et laiton. Câble avec interrupteur et prise de courant. Livrée avec ampoule. Egalement disponible comme suspension. ■ Riflettore in alluminio anodizzato e ottone. Cavo con interruttore e spina. Lampadina inclusa. Disponibile anche nella versione a sospensione. ■ Reflector de aluminio anodizado y latón. Cable con interruptor y enchufe. Suministrada con bombilla. También como lámpara de suspensión.

Grasl Vulgaris Jan Roth 1973

Geriffelter Reflektor aus Aluminium. Kabel mit Schalter und Stecker. Lieferung mit Glühlampe. Auch als Hängelampe. ■ Reflector: aluminium with "corrugated" surface. Cable with switch and plug. Complete with bulb. Also available as hanging lamp. ■ Réflecteur façon «tôle ondulée» en aluminium. Câble avec interrupteur et prise de courant. Livrée avec ampoule. Egalement disponible comme suspension. ■ Riflettore in alluminio ondulato. Cavo con interruttore e spina. Lampadina inclusa. Disponibile anche nella versione a sospensione. ■ Reflector estriado de aluminio. Cable con interruptor y enchufe. Suministrada con bombilla. También como lámpara de suspensión.



Los Minimalos Uno Ingo Maurer und Team 1994

Edelstahl, Stahlgewebe und Aluminium. Ein Kugelgelenk ermöglicht Drehen und Neigen in jede Richtung. Der Teleskoparm ist beweglich und ausziehbar, die Neigung des Reflektors ist variabel. Lieferung mit Leuchtmittel. ■ Stainless steel, steel mesh and aluminium. The ball-and-socket joint enables the lamp to be tilted and swivelled in any direction. The movable telescope arm is extendable, the reflector angle is freely adjustable. Complete with bulb. ■ Acier inoxydable, fibre d'acier et aluminium. Une articulation à rotule permet de tourner et d'incliner la lampe en toute direction. Le bras télescopique est mobile et s'étend. L'inclinaison du réflecteur est variable. Livrée avec ampoule. ■ Acciaio inossidabile, tessuto in acciaio e alluminio. Ruotabile e inclinabile in ogni direzione mediante un giunto sferico. Il braccio telescopico è mobile e allungabile. L'inclinazione del riflettore è variabile. Lampadina inclusa. ■ Acero inoxidable, tejido de acero y aluminio. La articulación permite el giro y la inclinación en todas las direcciones. El brazo telescópico es móvil y puede extenderse. La inclinación del reflector es variable. Suministrada con bombilla.



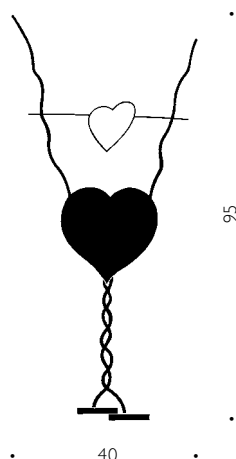
Little Big Lamp Ingo Maurer 2003

Stahl, Aluminium, Glas, Kunststoff. 230-Volt-Version: Integrierter Dimmer; durch Berührung des Stabes stufenlos regulierbar. 125-Volt-Version: Schiebedimmer und Kabel transparent. Stufenlos höhenverstellbar. Lieferung mit Leuchtmittel. ■ Steel, aluminium, glass, plastic. 230 volts version: integrated dimmer, continuously variable by touching the rod. 125 volts version: dimmer with slide control and transparent cable. Freely adjustable. Complete with bulb. ■ Acier, aluminium, verre, matière plastique. Version 230 volts: gradateur de lumière intégré, par simple toucher de la tige réglable sans graduation. Version 125 volts: gradateur de lumière coulissant et câble transparent. Réglage en hauteur sans graduation. Livrée avec ampoule. ■ Acciaio, alluminio, vetro, materiale sintetico. Versione 230 volt: varialuce integrato, regolabile in continuo toccando l'asta. Versione 125 volt: varialuce lineare e cavo trasparente. Regolazione continua dell'altezza. Lampadina inclusa. ■ Acero, aluminio, vidrio, plástico. Versión de 230 voltios: regulador integrado, a través del contacto con la varilla se regula continuamente en interrupciones. Versión de 125 voltios: regulador de intensidad y cable transparente. Ajuste de altura gradual. Suministrada con bombilla.



One From The Heart Ingo Maurer 1989

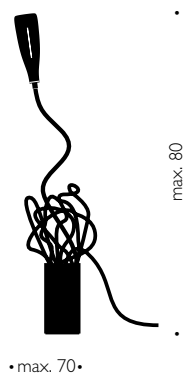
Metall, beweglicher Glas-Spiegel und Kunststoff. Multi Mirror-Reflektor mit Schutzglas.
 Lieferung mit Leuchtmittel. ■ Metal, plastic, adjustable glass mirror. Multi-Mirror reflector
 with protective glass cover. Complete with bulb. ■ Métal, miroir mobile en verre et
 matière plastique. Réflecteur Multi Mirror avec verre protecteur. Livrée avec ampoule. ■
 Metallo, specchio orientabile in vetro e materiale sintetico. Riflettore Multi Mirror con vetro
 di protezione. Lampadina inclusa. ■ Metal, espejo de cristal movible y plástico. Reflector
 Multi Mirror con cristal protector. Suministrada con bombilla.





Kuddelmuddel Tobias Reichle 2008

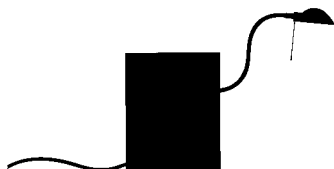
Metall, Kunststoff. Lampenfuß mit Kippschalter. Länge des flexiblen Arms 70 cm. Lieferung mit Leuchtmittel. ■ Metal, plastic. Base with toggle switch. Length of flexible arm 70 cm. Complete with bulb. ■ Métal, matière plastique. Pied avec interrupteur à bascule. Longueur du bras flexible 70 cm. Livrée avec ampoule. ■ Metallo, materiale sintetico. Base con interruttore a levetta. Lunghezza del braccio flessibile 70 cm. Lampadina inclusa. ■ Metal, plástico. Pie de lámpara con interruptor basculante. Largo del brazo flexible 70 cm. Suministrada con bombilla.





Oskar Ingo Maurer 1998

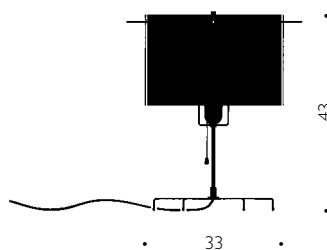
Oskar see page 220





24 Karat Blau T Axel Schmid 2005

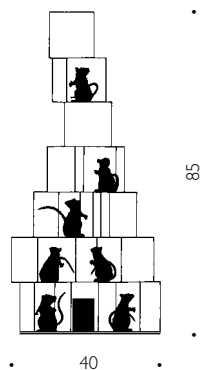
Metall, in Kunststoff eingegossenes Blattgold. Die vier goldenen Blenden können am Stabkreuz in verschiedenen Winkeln und Positionen aufgehängt werden. Lieferung mit Leuchtmittel. ■ Metal, gold leaf sealed in plastic. The four golden shades can be hung in various angles and positions. Complete with bulb. ■ Métal, matière plastique, feuille d'or. Les quatres écrans peuvent être suspendus dans différents angles et positions. Livrée avec ampoule. ■ Metallo, foglio d'oro laminato con materiale sintetico. I quattro paralumi d'oro possono essere appesi sull'asta a croce in vari angoli e posizioni. Lampadina inclusa. ■ Metal, lámina de oro colada en plástico. Las cuatro pantallas doradas pueden ser colgadas del varillaje en diferentes ángulos y posiciones. Suministrada con bombilla.

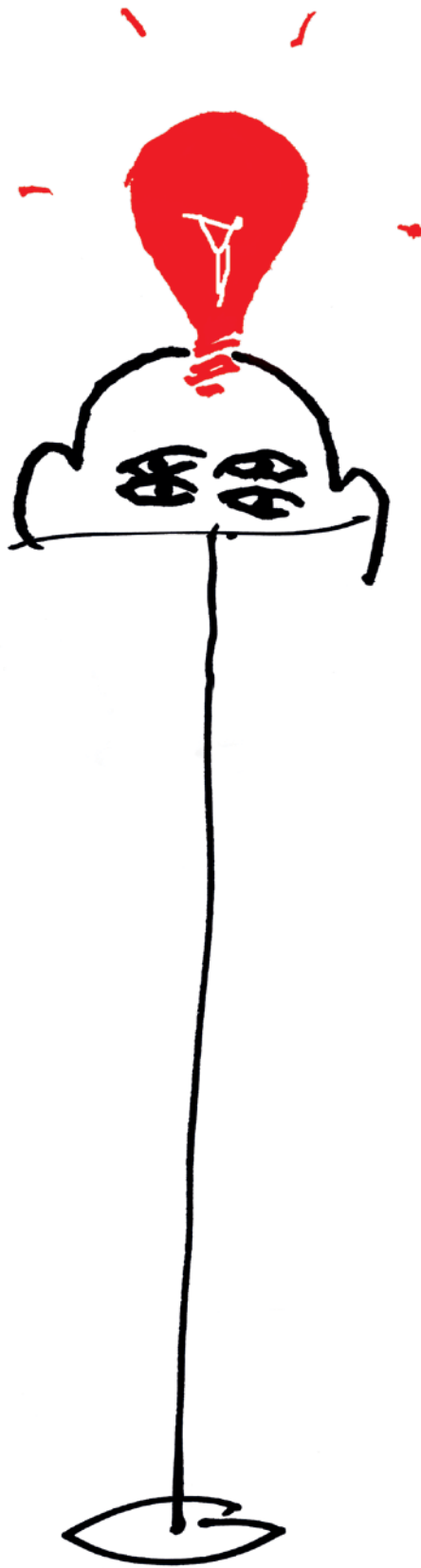




Seven Rats Ingo Maurer und Team 2007

Stahl, Gold, Messing, Kunststoff. Vier schwarze und drei weiße Kunststoffratten. Lieferung mit Leuchtmittel. ■ Steel, gold, brass, plastic. Four black and three white plastic rats. Complete with bulb. ■ Acier, or, laiton, matière plastique. Quatre rats noirs et trois rats blancs en matière plastique. Livrée avec ampoule. ■ Acciaio, oro, ottone, materiale sintetico. Quattro topi neri e tre topi bianchi di materiale sintetico. Lampadina inclusa. ■ Acero, oro, latón, plástico. Cuatro ratas negras y tres blancas de plástico. Suministrada con bombilla.

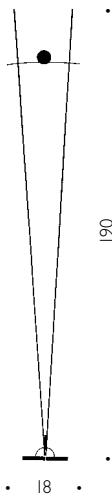




Stehlampen / Floor lamps / Lampadaires / Lampade a stelo / Lámparas de pie

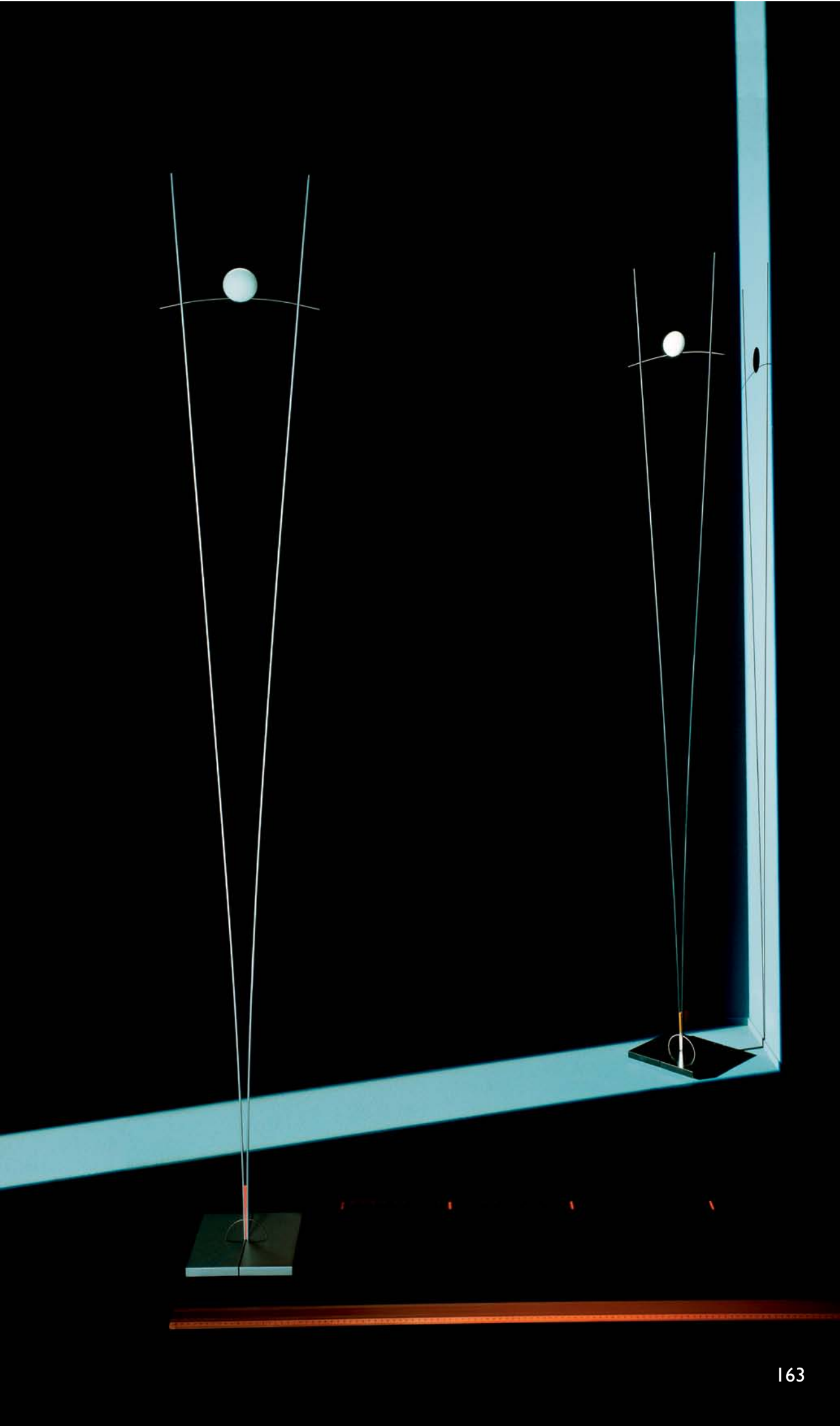


Photo of the moon taken in the desert of Namibia by Markus Tollhopf.



Ilios Ingo Maurer, Franz Ringelhan 1983

Silber oder schwarz. Metall und Glas, Isolationskeil fluoreszierend rot. Lieferung mit Leuchtmittel. ■ Choice of silver or black metal, glass, red fluorescent insulator. Complete with bulb. ■ Argent ou noir. Métal et verre, pièce d'isolation rouge fluorescente. Livrée avec ampoule. ■ Argento o nero. Metallo e vetro, elemento isolante rosso fluorescente. Lampadina inclusa. ■ Plata o negro. Metal y vidrio, cuña de aislamiento en rojo fluorescente. Suministrada con bombilla.





• 18 •

aR-ingo Ron Arad, Ingo Maurer 1984/2006

Aluminium in Wabenstruktur, Stahl. Kabel mit Schalter; kein Dimmer. Lieferung mit Leuchtmittel. ■ Aluminium in honeycomb structure, steel. Cable with switch, no dimmer. Complete with bulb. ■ Aluminium à structure alvéolaire. Câble avec interrupteur, sans variateur d'intensité lumineuse. Livrée avec ampoule. ■ Alluminio con struttura a nido d'ape. Cavo con interruttore, senza variatore di intensità. Lampadina inclusa. ■ Aluminio con estructura alveolar, acero. Cable con interruptor, sin regulador continuo de intensidad. Suministrada con bombilla.





Metall F. Cooper *Ingo Maurer und Team 2009*

Metall, Kunststoff. Die obere flexible Hälfte des Stabes ermöglicht die variable Einstellung des Reflektors. Reflektor 360° um das Leuchtmittel drehbar. Stufenlos dimmbar. Lieferung mit Leuchtmittel. ■ Metal, plastic. The upper flexible half of the stem allows variable adjustment. Reflector rotates through 360° around the bulb. Continuously variable dimmer. Complete with bulb. ■ Métal, matière plastique. La moitié supérieure et flexible de la tige permet le réglage variable du réflecteur. Réflecteur rotatif de 360° autour de l'ampoule. Réglage de l'intensité lumineuse sans graduation. Livrée avec ampoule. ■ Metallo, materiale sintetico. La parte superiore dell'asta è flessibile e permette la regolazione variabile del riflettore. Riflettore rotante di 360° intorno alla lampadina. Regolazione continua dell'intensità luminosa. Lampadina inclusa. ■ Metal, plástico. La mitad superior flexible de la varilla permite el ajuste variable del reflector. Reflector giratorio alrededor de la bombilla hasta 360°. Con regulador continuo de intensidad. Suministrada con bombilla.

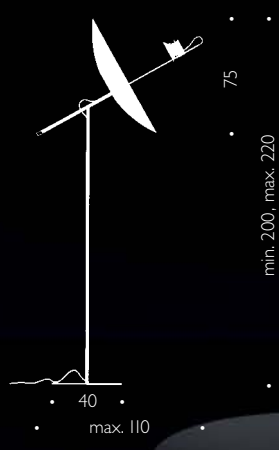


Alizz F. Cooper Ingo Maurer und Team 2008

Metall, Kunststoff, Gummischlauch. Die obere flexible Hälfte des Stabes ermöglicht die variable Einstellung des Reflektors. Reflektor 360° um das Leuchtmittel drehbar. Stufenlos dimmbar. Lieferung mit Leuchtmittel. ■ Metal, plastic, rubber hose. The upper flexible half of the stem allows variable adjustment. Reflector rotates through 360° around the bulb. Continuously variable dimmer. Complete with bulb. ■ Métal, matière plastique, tuyau en caoutchouc. La moitié supérieure et flexible de la tige permet le réglage variable du réflecteur. Réflecteur rotatif de 360° autour de l'ampoule. Réglage de l'intensité lumineuse sans graduation. Livrée avec ampoule. ■ Metallo, materiale sintetico, tubo di gomma. La parte superiore dell'asta è flessibile e permette la regolazione variabile del riflettore. Riflettore rotante di 360° intorno alla lampadina. Regolazione continua dell'intensità luminosa. Lampadina inclusa. ■ Metal, plástico, manguera de caucho. La mitad superior flexible de la varilla permite el ajuste variable del reflector. Reflector giratorio alrededor de la bombilla hasta 360°. Con regulador continuo de intensidad. Suministrada con bombilla.



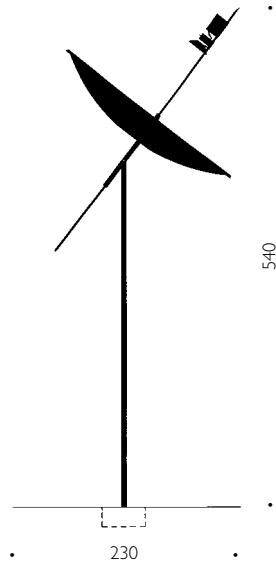






Satel.light *Ingo Maurer und Team 2005*

Fiberglas, Metall, Aluminium. Stufenlos dimmbar. Stab um 350° drehbar, Arm mit Reflektorschale um ca. 90° schwenkbar. Lieferung mit Leuchtmittel. ■ Fibreglass, metal, aluminium. Continuously variable dimmer. Stem rotates through 350°, arm with reflector dish tilts through approx. 90°. Complete with bulb. ■ Fibre de verre, métal, aluminium. Réglage de l'intensité lumineuse sans graduation. Tige rotative à 350°, bras avec antenne orientable à 90°. Livrée avec ampoule. ■ Vetroresina, metallo, alluminio. Regolazione continua dell'intensità luminosa. Asta rotante di 350°, braccio con riflettore basculante di ca. 90°. Lampadina inclusa. ■ Fibra de vidrio, aluminio. Dimmer sin escalones. Varilla giratoria de 350°, brazo con lámina reflectora inclinable aprox. 90°. Suministrada con bombilla.



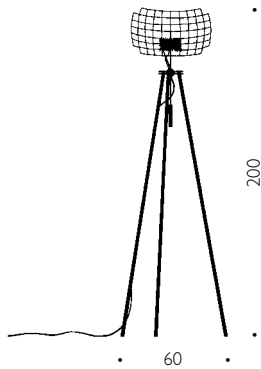
Big Dish Floor Ingo Maurer und Team 2005

Fiberglass, Aluminium, Stahl. Variante mit stufenlosem Dimmer; Farbeinstellung und DMX-Ansteuerung auf Anfrage. Eingelassener Sockel, Einbautiefe 20 cm. Die Orientierung der Reflektorschale ist auch nach Montage um 360° veränderbar. ■ Fiberglass, aluminium, steel. Version with continuously variable dimmer; colour setting and DMX control available on request. Recessed floor mounting, installation depth 20 cm. The orientation of the reflector dish is adjustable through 360° also after installation. ■ Fibre de verre, aluminium, acier. Version avec réglage d'intensité lumineuse sans gradation, de mélange des couleurs et commande d'éclairage avec DMX disponible sur demande. Socle encastré dans le sol, profondeur 20 cm. L'orientation de l'antenne est réglable à 360° même après l'installation. ■ Vetroresina, metallo, acciaio. Versione con variazione continua dell'intensità luminosa e del colore, comando DMX disponibile su richiesta. Base incassata nel pavimento, profondità di montaggio 20 cm. La direzione dell' antenna è regolabile di 360° anche dopo l'installazione. ■ Fibra de vidrio, aluminio, acero. Variante con regulador continuo de intensidad, con ajuste de color y control DMX por encargo. Casquillo empotrado, profundidad de colocación 20 cm. La orientación del plato reflector puede ser modificado tras su instalación hasta un ángulo de 360°.



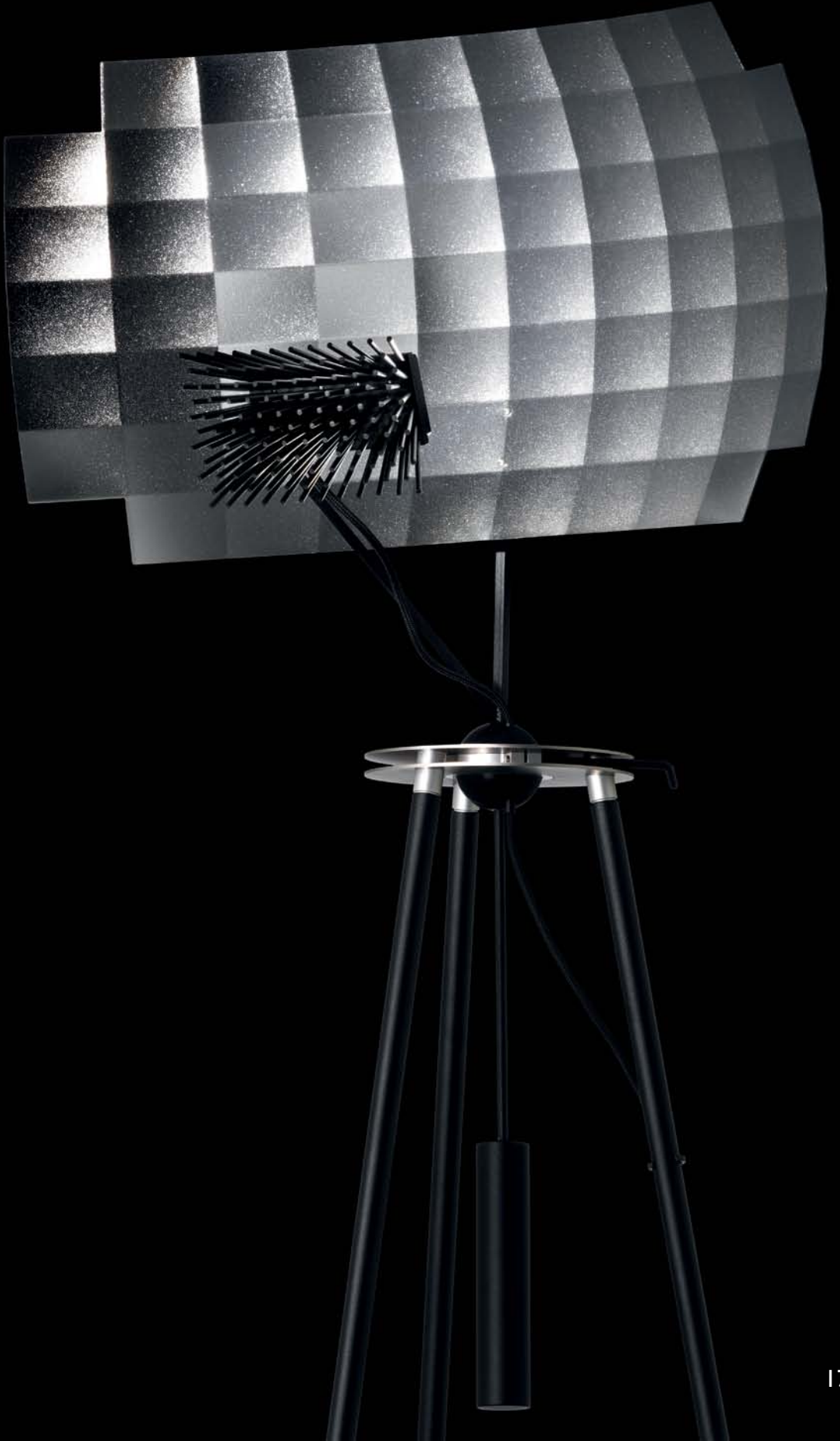


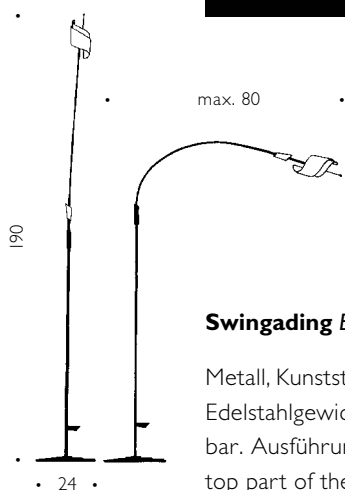




Radarr Ingo Maurer und Team 2010

Stahl, Aluminium. Kabel mit Schalter und elektronischem Vorschaltgerät. Nicht dimmbar. Ein Kugelgelenk ermöglicht den facettierten Schirm zu neigen und zu drehen. Lieferung mit Leuchtmittel. ■ Steel, aluminium. Cable with switch and electronic ballast. Not dimmable. A ball-joint makes it possible to turn and tilt the screen. Complete with bulb. ■ Acier, aluminium. Câble avec interrupteur et ballast électronique. Non dimmable. L'articulation à rotule permet de tourner et d'incliner l'écran. Livrée avec ampoule. ■ Acciaio, alluminio. Cavo con interruttore e alimentatore elettronico. Non dimmerabile. Rotabile e basculante mediante un giunto a sfera. Lampadina inclusa. ■ Acero, aluminio. Cable con interruptor y balastro electrónico. No regulable en intensidad. La articulación esférica permite girar e inclinar el reflector. Suministrada con bombilla.





Swingading Bernhard Dessecker 1993

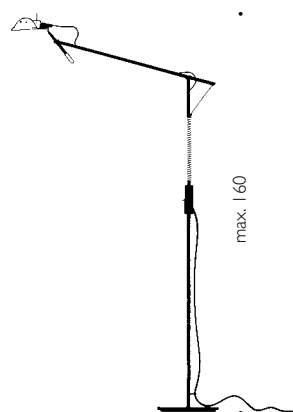
Metall, Kunststoff, Glas. Stab flexibel ab 100 cm Höhe durch ein stufenlos bewegliches Edelstahlgewicht. Reflektor mit Schutzglas. Reflektor und Blenden sind um 360° drehbar. Ausführung nur in Schwarz. Lieferung mit Leuchtmitteln. ■ Metal, plastic, glass. The top part of the stem (above 100 cm) is flexible and can be fixed in the required position by moving the stainless-steel weight. Reflector fitted with protective glass cover. Reflector and shades freely rotatable. Only in black. Complete with bulbs. ■ Métal, matière plastique, verre. Tige flexible à partir d'une hauteur de 100 cm par un contrepois coulissant en acier spécial. Réflecteur avec verre protecteur. Réflecteur et écran sont orientables sur 360°. Seulement en noir. Livrée avec ampoules. ■ Metallo, materiale sintetico. Asta flessibile a partire da 100 cm d'altezza mediante un peso scorrevole in acciaio inossidabile. Riflettore con vetro di protezione. Il riflettore e gli schermi ruotano di 360°. Solamente in nero. Lampadine incluse. ■ Metal, plástico, cristal. Varilla flexible a partir de los 100 cm gracias a un contrapeso de acero fino movable sin escalonamiento. Reflector de cristal protector. El reflector y la mampara se pueden girar hasta 360°. Disponible en negro. Suministrada con bombillas.

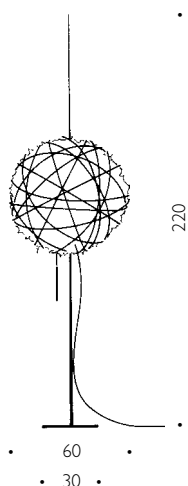




Prototype Floor Bernhard Dessecker, Ingo Maurer 2004

Aluminium, Edelstahl, Metall, Kunststoff, Silikon. Um 360° drehbar. Horizontaler Arm, Leuchtenkopf und Reflektor verstellbar. Lieferung mit Leuchtmittel. ■ Aluminium, stainless steel, metal, plastic, silicone. Rotable through 360°. Horizontal arm, lamp head and reflector adjustable. Complete with bulb. ■ Aluminium, inoxydable, métal, matière plastique, silicone. Rotatif à 360°. Bras horizontal, tête et réflecteur réglables. Livrée avec ampoule. ■ Alluminio, acciaio inossidabile, metallo, materiale sintetico, silicone. Ruota di 360°. Braccio orizzontale, testina e riflettore orientabili. Lampadina inclusa. ■ Aluminio, acero fino, metal, plástico, silicona. Giratoria hasta 360°. Brazo horizontal, cabeza de la lámpara y reflector ajustables. Suministrada con bombilla.





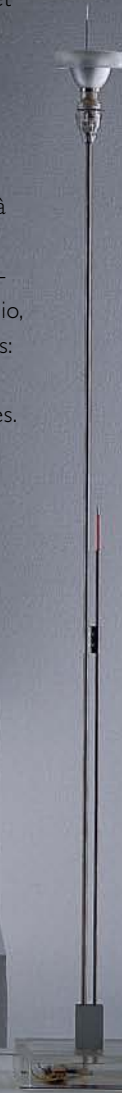
Knüller Bernhard Dessecker 2004

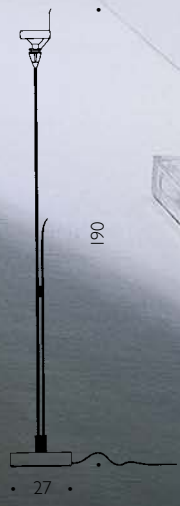
Glasfaser, Metall, Kunststoff, Seidenpapier. Integriertes elektronisches Tandem-Vorschaltgerät. Zugschalter fluoreszierend. Lieferung mit Leuchtmitteln. ■ Fibreglass, metal, plastic, tissue paper. Integrated electronic tandem ballast. Fluorescent pull switch. Complete with bulbs. ■ Fibre de verre, métal, matière plastique, papier de soie. Ballast tandem électronique intégré. Tirette fluorescente. Livrée avec ampoules. ■ Vetroresina, metallo, materiale sintetico, carta seta. Alimentatore elettronico bilampada integrato. Interruttore a catenella fluorescente. Lampadine incluse. ■ Fibra de vidrio, metal, plástico, papel de seda. Equipo electrónico integrado y colocado en paralelo al fuste de la lámpara. Interruptor de tiro fluorescente. Suministrada con bombillas.



Stand Up ForYour Light Bernhard Dessecker 1998

Edelstahl, Aluminium, Kunststoff. Fuß und Fassung aus transparentem Glas. 230 Volt: Stufenlos dimmbar durch Sensorschalter. 125 Volt: Stufenlos dimmbar mit Schieberegler. Dimmer und Kabel transparent. Lieferung mit Leuchtmittel. ■ Stainless steel, aluminium, plastic, base and socket in transparent glass. 230 volts: Continuously variable dimmer with sensor switch. 125 volts: Continuously variable with slide control. Dimmer and cable transparent. Complete with bulb. ■ Acier inoxydable, aluminium, matière plastique. Socle et douille en verre transparent. 230 volts: Réglage de l'intensité lumineuse sans graduation par interrupteur-sensor. 125 volts: Réglage de l'intensité lumineuse sans graduation par curseur. Gradateur et câble transparents. Livrée avec ampoule ■ Acciaio inossidabile, alluminio, materiale sintetico. Base e portalampada in vetro trasparente. 230 volt: Regolazione continua dell'intensità luminosa mediante interruttore a sensore. 125 Volt: regolazione continua dell'intensità luminosa mediante variatore lineare. Variatore e cavo trasparenti. Lampadina inclusa. ■ Acero fino, aluminio, plástico. Pie y portalámparas de cristal transparente. 230 voltios: ajustable regulador continuo gracias al interruptor sensible. 125 voltios: regulador continuo. Regulador y cable transparentes. Suministrada con bombillas.





190





• ca. 50 •

• min. 50, max. 95 •



Birdie's Nest Ingo Maurer 2005

Metall, Flügel aus Gänsefedern, zehn Niedervolt-Glühlampen, transparente Kabel. Lieferung mit 2 Ersatzglühlampen. Birdie's Nest ist für Räume mit geringen Deckenhöhen konzipiert. Nicht geeignet für Räume mit hoher Luftfeuchtigkeit. ■ Metal, goose-feather wings, ten low-voltage bulbs, transparent cables. Complete with bulbs plus 2 spares. Birdie's Nest is designed for rooms with lower ceilings. Not suited for rooms with high humidity. ■ Métal, ailes en plumes d'oie, dix ampoules à bas voltage, câbles transparents. Livrée avec 2 ampoules de rechange. Birdie's Nest est conçu pour des pièces à plafond bas. N'est pas appropriée pour des pièces avec un fort taux humidité. ■ Metallo, ali in piume d'oca, dieci lampadine a basso voltaggio, cavi trasparenti. Include 2 lampadine di ricambio. Birdie's Nest è concepita per soffitti bassi. Non adatta all'uso in ambienti ad alta umidità. ■ Metal, alas de plumas de oca, diez bombillas de bajo voltaje, cables transparentes. Suministrada con 2 bombillas de recambio. Birdie's Nest ha sido diseñada para ambientes con techos de poca altura. No es apta para ambientes con un alto porcentaje de humedad.

24 V Halogen EU approved



Made to be co-designed by you.

Enjoy the ability to style it anyway you wish.



Luxury Pure Ingo Maurer und Team 2004

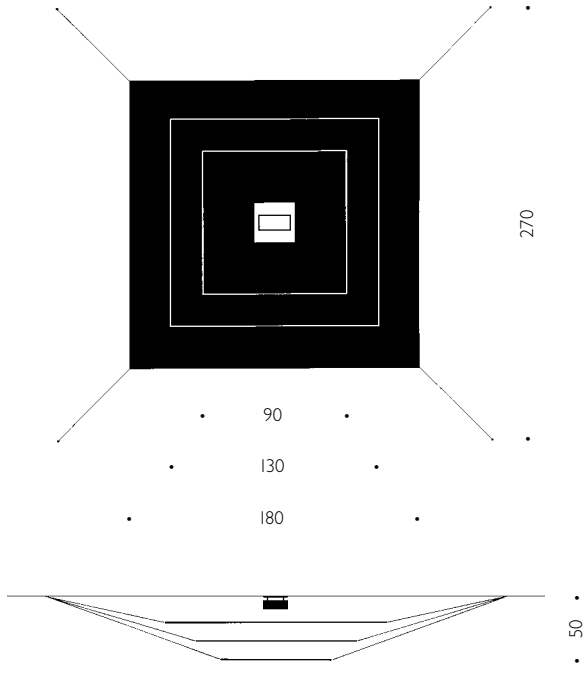
Gold oder silbern lackiertes Papier; Aluminium. Aufhängung an Seilen aus Polyestergeflecht. Für Raumhöhen ab 270 cm. Lieferung mit Leuchtmittel. Segel 1: 180 x 180 cm. Segel 2: 130 x 130 cm. Segel 3: 90 x 90 cm. Abstand der Deckenhalterung: 270 x 270 cm.

■ Gold or silver lacquered paper, aluminium. For ceiling heights of 270 cm and more. Suspension with braided polyester strings. Complete with bulb. Sail 1: 180 x 180 cm. Sail 2: 130 x 130 cm. Sail 3: 90 x 90 cm. Spacing of ceiling fixtures : 270 x 270 cm. ■ Papier laqué or ou argent, aluminium. Pour hauteurs de pièces à partir de 270 cm. Suspension par fils en polyester tressé. Livrée avec ampoule. Voile 1: 180 x 180 cm. Voile 2: 130 x 130 cm. Voile 3: 90 x 90 cm. Distance des suspensions: 270 x 270 cm. ■ Carta verniciata oro o argento, alluminio. Sospensione con fili in poliestere intrecciato. Per soffitti con altezza a partire da 270 cm. Lampadina inclusa. Vela 1: 180 x 180 cm. Vela 2: 130 x 130 cm. Vela 3: 90 x 90 cm. Distanza delle sospensioni: 270 x 270 cm. ■ Papel lacado en oro o plata, aluminio. La suspensión se realiza a través de hilos de poliéster. Para habitaciones con una altura superior a los 270 cm. Suministrada con bombilla. Vela 1: 180 x 180 cm. Vela 2: 130 x 130 cm. Vela 3: 90 x 90 cm. Distancia de la suspensión: 270 x 270 cm.

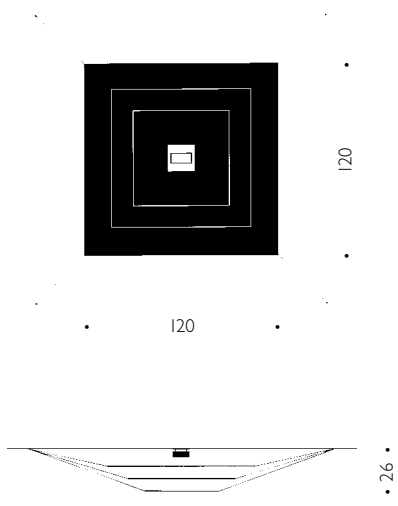


Lil Luxury Ingo Maurer und Team 2009

Gold, silbern oder weiß lackiertes Papier, Aluminium. Aufhängung an Seilen aus Polyestergeflecht. Für Raumhöhen ab 240 cm. Lieferung mit Leuchtmittel. Segel 1: 120 x 120 cm. Segel 2: 89 x 89 cm. Segel 3: 65 x 65 cm. Abstand der Deckenhalterung: 200 x 200 cm. ■ Gold, silver or white lacquered paper, aluminium. For ceiling heights of 240 cm and more. Suspension with braided polyester strings. Complete with bulb. Sail 1: 120 x 120 cm. Sail 2: 89 x 89 cm. Sail 3: 65 x 65 cm. Spacing of ceiling fixtures: 200 x 200 cm. ■ Papier laqué or, argent ou blanc, aluminium. Pour hauteurs de pièces à partir de 240 cm. Suspension par fils en polyester tressé. Livrée avec ampoule. Voile 1: 120 x 120 cm. Voile 2: 89 x 89 cm. Voile 3: 65 x 65 cm. Distance des suspensions: 200 x 200 cm. ■ Carta verniciata oro, argento o bianco, alluminio. Sospensione con fili in poliestere intrecciato. Per soffitti con altezza a partire da 240 cm. Lampadina inclusa. Vela 1: 120 x 120 cm. Vela 2: 89 x 89 cm. Vela 3: 65 x 65 cm. Distanza delle sospensioni: 200 x 200 cm. ■ Papel lacado en oro, plata o blanco, aluminio. La suspensión se realiza a través de hilos de poliéster. Para habitaciones con una altura superior a los 240 cm. Suministrada con bombilla. Vela 1: 120 x 120 cm. Vela 2: 89 x 89 cm. Vela 3: 65 x 65 cm. Distancia de la suspensión: 200 x 200 cm.



Luxury Pure



Lil Luxury



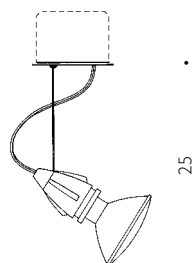
Lil Luxury

Auch erhältlich in Weiß – Also available in white – Disponible aussi en blanc
Anche disponibile in bianco – También disponible en blanco



Spock Bernhard Dessecker 1998

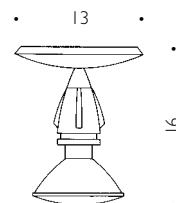
Edelstahl, Glas, Aluminium. Der Strahler ist über ein Kugelgelenk einstellbar. Aufputz-Montagedose mit Abdeckscheibe Ø 8 cm. Die Montage auf eine Unterputzdose ist ebenfalls möglich. Auch an der Wand zu montieren. Lieferung mit Leuchtmittel. ■ Stainless steel, glass, aluminium. Adjustable via ball-joint. Box with cover Ø 8 cm, for surface mounting. Flush mounting also possible, or can be fixed to wall. Complete with bulb. ■ Acier inoxydable, verre, aluminium. Le spot est orientable par articulation à rotule. Boîte pour le montage sur crépi avec rondelle de recouvrement Ø 8 cm. Le montage sur une boîte encastrable sous crépi est également faisable. Possibilité de montage en applique. Livrée avec ampoule. ■ Acciaio inossidabile, vetro, alluminio. Il faretto è regolabile mediante un giunto sferico. Scatola di derivazione esterna a soffitto con rosone Ø cm. 8. Possibilità di montaggio con una scatola di derivazione incassata. E' possibile montarla anche a parete. Lampadina inclusa. ■ Acero fino, cristal, aluminio. El foco se puede ajustar gracias a su articulación esférica. Incluye caja de montaje en el florón de Ø 8 cm. Se puede colocar en la pared o en el techo. Suministrada con bombilla.





Sista Bernhard Dessecker 1998

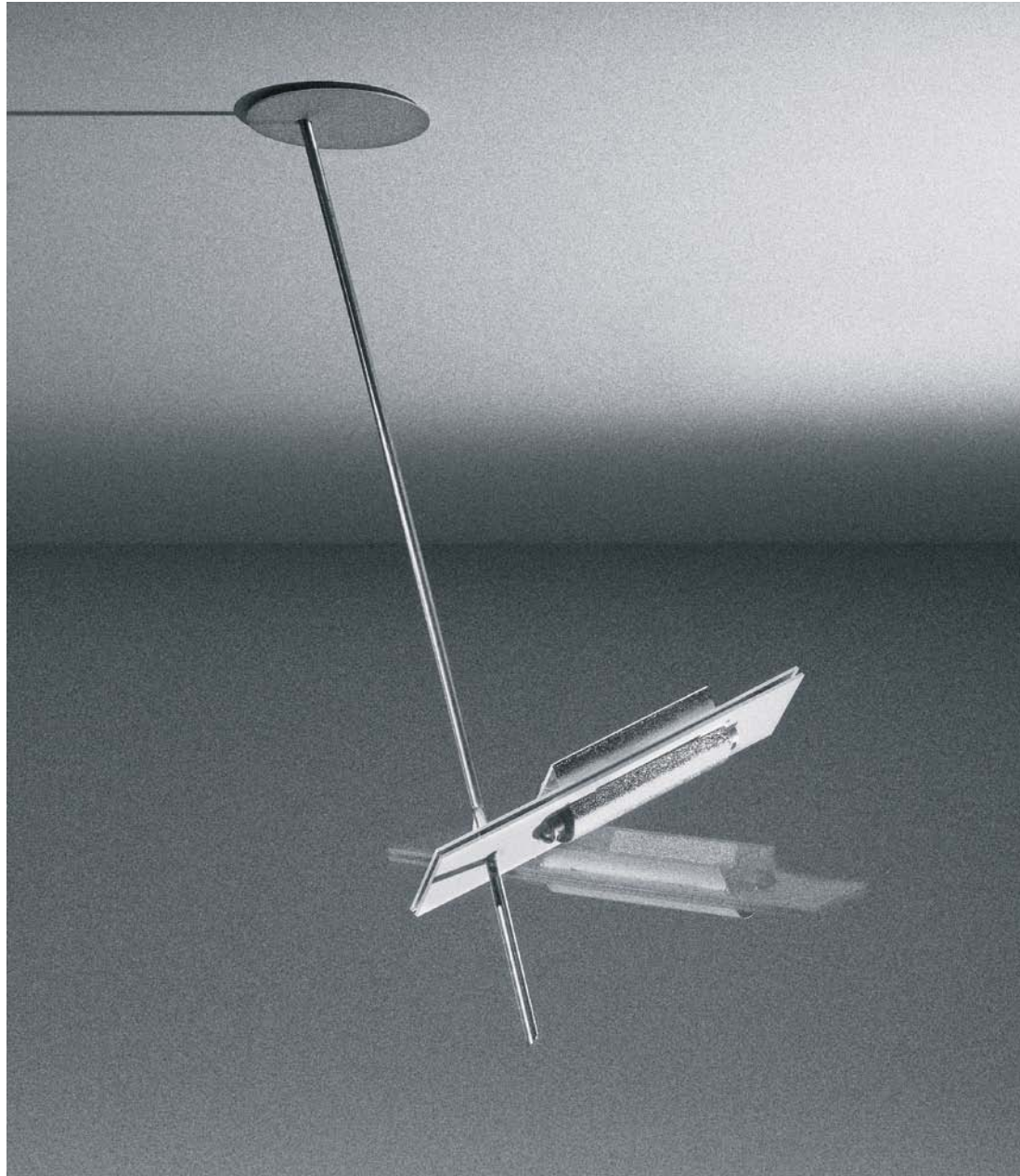
Metall, Kunststoff. Glasfassung direkt mit dem transparenten Baldachin verbunden. Lieferung mit Leuchtmittel. ■ Metal, plastic. Glass socket directly integrated into the transparent canopy. Complete with bulb. ■ Métal, matière plastique, verre. Douille en verre liée directement au baldachin transparent. Livrée avec ampoule. ■ Metallo, materiale sintetico. Portalampada in vetro direttamente collegato al rosone trasparente. Lampadina incluse. ■ Metal, plástico. Portalámpara de cristal conectado directamente con el florón transparente. Suministrada con bombilla.





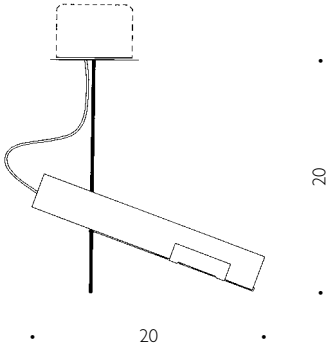
Zuuk Ingo Maurer 1994

Edelstahl, farblos eloxiertes Aluminium, hitzebeständiges satiniertes Glas. Nicht verstellbar. Lieferung mit Leuchtmittel, Aufputz-Montagedose und eloxierter Abdeckscheibe Ø 8 cm. Die Montage auf eine Unterputzdose ist ebenfalls möglich. ■ Stainless steel, anodized aluminium, heat-resistant satin-frosted glass. Non-adjustable. Complete with bulb, surface-mounted ceiling fixture and anodized base-plate cover Ø 8 cm. Flush mounting also possible. ■ Acier inoxydable, aluminium anodisé incolore, verre satiné résistant à la chaleur. Pas de possibilité de réglage en hauteur. Livrée avec ampoule, boîtier pour le montage sur crépi et rondelle de recouvrement Ø 8 cm en aluminium anodisé. Possibilité de montage en applique. ■ Acciaio inossidabile, alluminio anodizzato naturale, vetro satinato termoresistente. Non regolabile. Lampadina, scatola di derivazione esterna e rosone anodizzato Ø cm. 8 inclusa. E' possibile montarla anche su una scatola di derivazione incassata. ■ Acero inoxidable, aluminio galvanizado, vidrio satinado termoestable. No reajutable. Suministrada con bombilla, caja de montaje sobre revoque y disco cobertor, Ø 8 cm. También es posible montar sobre una caja bajo revoque.

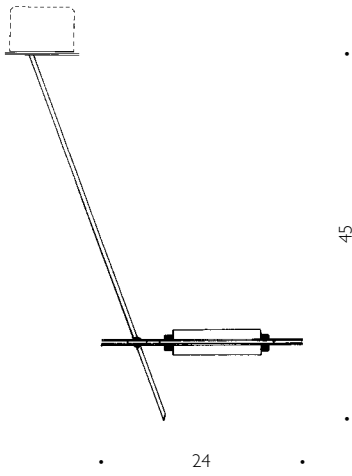
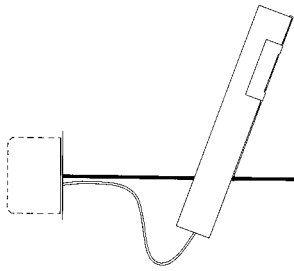


Wandering Finger Ingo Maurer 1994

Edelstahl, eloxiertes Aluminium, hitzebeständiges Schutzglas. Der Reflektor ist über ein Kippgelenk verstellbar. Mit Leuchtmittel, Aufputz-Montagedose und aluminium-farbener Abdeckscheibe Ø 9 cm. Die Montage auf eine Unterputzdose ist ebenfalls möglich. ■ Stainless steel, anodized aluminium, heat-resistant protective glass cover. The ball-and-socket joint makes the reflector angle freely adjustable. Complete with bulb, surface-mounted ceiling fixture and aluminium-finish base-plate cover Ø 9 cm. Flush mounting also possible. ■ Acier inoxydable, aluminium anodisé, verre protecteur résistant à la chaleur. Le réflecteur est orientable par une articulation à bascule. Livrée avec ampoule, boîtier pour le montage sur crépi et rondelle de recouvrement de couleur aluminium Ø 9 cm. Possibilité de montage en applique. ■ Acciaio inossidabile, alluminio anodizzato, vetro di protezione termoresistente. Il riflettore è regolabile mediante un giunto basculante. Lampadina, scatola di montaggio e rosone di colore alluminio Ø cm. 9 inclusa. E' possibile montarla anche su una scatola da incasso. ■ Acero inoxidable, aluminio galvanizado, vidrio protector termoestable. El reflector puede reajustarse mediante una articulación abatible. Suministrada con bombilla, caja de montaje en el florón color aluminio Ø 9 cm. También es posible montar sobre una caja bajo revoque.



Zuuk
max. 60 W Halogen BI5d

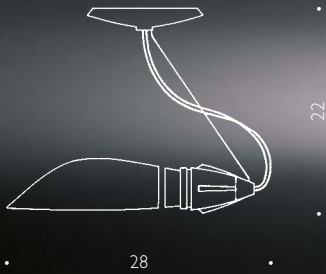


Wandering Finger
max. 150 W Halogen R7s



Comic Explosion, 2010.
Special commission available on request.

Length approx. 3 m



28

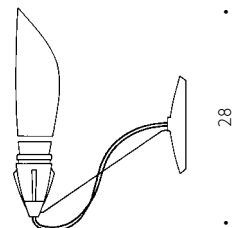


22

Lampeduso Bernhard Dessecker 1994

Kunststoff, Glas, Metall. Blende aus hitzebeständigem Glasgewebe. Empfohlene Leuchtmittel: Kompakt-Leuchtstofflampe 7/11 Watt oder Halogen-Röhrenlampe, max. 60 Watt. Baldachin Ø 13 cm, transparent. Lieferung ohne Leuchtmittel. ■ Plastic, glass, metal, heat-resistant glass fabric shade. Recommended bulbs: compact fluorescent bulb 7/11 watts or halogen tubular lamp, max 60 watts. Canopy Ø 13 cm, transparent. Bulb not included. ■ Matière plastique, verre, métal. Ecran en fibre de verre résistant à la chaleur. Ampoules recommandées: ampoule fluorescente compacte 7/11 watts ou ampoule halogène tube, max. 60 Watt. Baldaquin, Ø 13 cm, transparent. Livrée sans ampoule. ■ Materiale sintetico, vetro, metallo. Schermo in tessuto di vetro termoresistente. Lampadine consigliate: lampada fluorescente 7/11 watt o lampadina alogena tubolare, max. 60 watt. Rosone Ø cm. 13, trasparente. Lampadina non inclusa. ■ Plástico, vidrio, metal. Pantalla de tejido de vidrio termoestable. Bombillas recomendadas: lámparas fluorescentes compactas 7/11 vatios o tubos halógenos, máx. 60 vatios. Florón, Ø 13 cm, transparente. Suministrada sin bombilla.

One lamp, two uses: ceiling or wall.



28

22



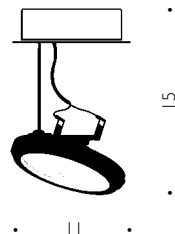
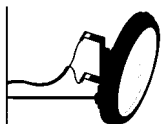
Tooling Christoph Matthias 2004

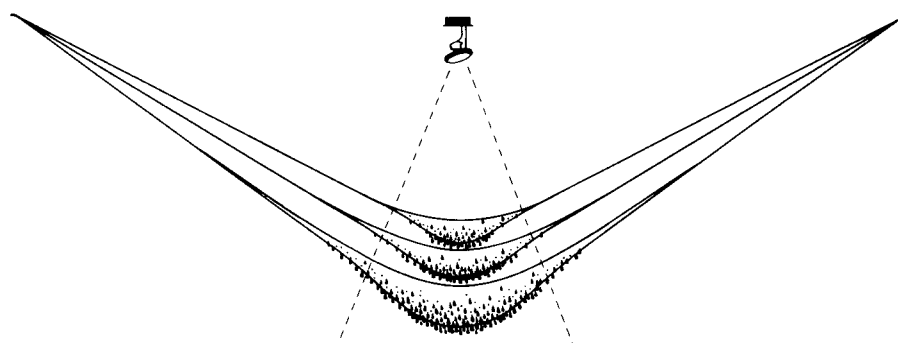
Aluminium, Edelstahl, Kunststoff. Leuchtenkopf um 180° drehbar und um 45° schwenkbar. Der Reflektor ist matt grau lackiert. Aufputzmontage mit Abdeckscheibe Ø 8 cm. Die Montage ist auch auf Unterputzdose möglich. Lieferung mit Leuchtmittel. ■ Aluminium, stainless steel, plastic. Head of lamp rotates through 180° and tilts through 45°. The reflector has a mat grey finish. With surface-mounted wall fixture and base-plate cover Ø 8 cm. Flush-mounted installation is also possible. Complete with bulb. ■ Aluminium acier inoxydable, matière plastique. Tête de lampe rotative à 180° et inclinable à 45°. Montage sur crépi avec rondelle de recouvrement Ø 8 cm. Montage sur boîtier encastrable sous crépi possible. Livrée avec ampoule. ■ Alluminio, acciaio inossidabile, materiale sintetico. Il riflettore ruota di 180° e si inclina di 45°. La superficie esterna del riflettore è verniciata grigio opaco. Scatola di derivazione esterna con piastra di copertura Ø 8 cm. È possibile il montaggio su una scatola di derivazione incassata. Lampadina inclusa. ■ Aluminio, acero fino, plástico. La cabeza de la lámpara se puede girar hasta 180° e inclinarse hasta 45°. El reflector está lacado en color gris mate. Incluye caja de montaje en el florón de Ø 8 cm. También se puede montar empotrada. Suministrada con bombilla.



Use Me C. Ingo Maurer und Team, 2010

Edelstahl, Aluminium. Der Strahler ist über ein Kugelgelenk einstellbar. Das Leuchtmittel ist im Handel auch in anderen Ausstrahlungswinkeln und Wattagen erhältlich. Lieferung mit Leuchtmittel. ■ Stainless steel, aluminium. Adjustable via one ball-joint. In trade the light source is also available with other angles and wattages. Complete with bulb. ■ Acier inoxydable, aluminium. Spot ajustable par une articulation à rotule. L'halogène est aussi disponible en magasin avec d'autres angles et wattages. Livrée avec ampoule. ■ Acciaio inossidabile, alluminio. Il faretto è regolabile mediante un giunto a sfera. La lampadina è anche disponibile in commercio con altri angoli d'irradiazione e wattagi. Lampadina inclusa. ■ Acero inoxidable, aluminio. El foco se puede ajustar gracias a su atriculación esférica. La bombilla también está disponible en comercio en otros ángulos del haz y potencias. Suministrada con bombilla.





Use Me C. can be used as a downlight combination with
Lacrime del Pescatore, both sold separately.



Light Cones:
Downlight solution 1, 2 + 3

Fünf unterschiedliche Deckeneinbaulampen für Downlight-Lösungen, die über das **Übliche** hinausgehen.

Five different lighting options, to create solutions for downlighting that are certainly beyond the ordinary.

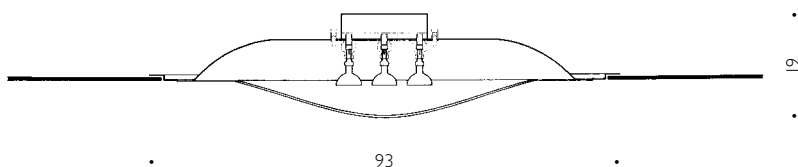
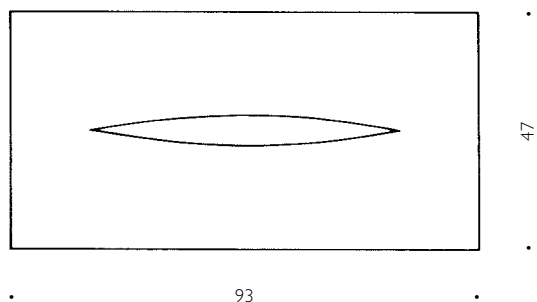
Cinq options différentes d'éclairage pour créer des solutions d'éclairage vers le bas, sortant de l'ordinaire.



Schlitz Up:
Downlight solution 4 + 5

Cinque opzioni d'illuminazione differenti, per creare un'illuminazione singolare verso il basso.

Cinco distintas variantes luminosas para crear soluciones de iluminación cenital que superan lo ordinario.



Schlitz Up Ingo Maurer 2002

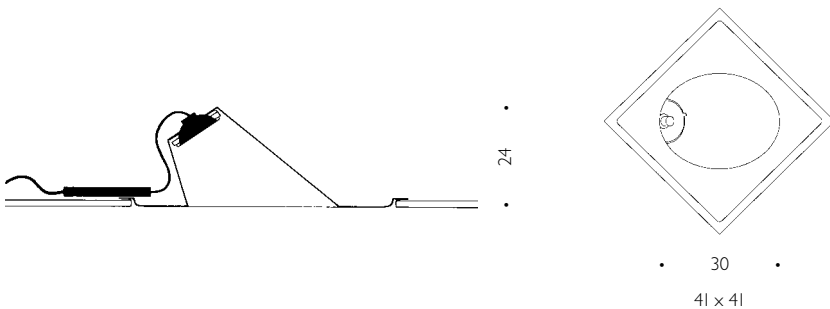
Aluminium, GFK. Deckenlampe für Einbau in abgehängte Decken, Einbautiefe min. 15 cm. Sondergrößen auf Anfrage. Durch Kugelgelenke justierbare Multi Mirror-Reflektoren lenken das Licht an verschiedene Positionen. Die Innenflächen können auf Wunsch auch in anderen kontrastreichen Farben lackiert werden. ■ Aluminium, glass fibre. Ceiling lamp for flush mounting into lowered ceilings, installation depth 15 cm min. Alternative dimensions on request. Multimirror reflectors, adjustable by means of ball-joints, direct the light to various positions. On request, the inner surface can be lacquered in several contrast colours. ■ Aluminium, fibre de verre. Plafonnier pour montage sur plafonds surbaissés, profondeur de montage 15 cm. Dimensions spéciales sur demande. Des réflecteurs Multi Mirror réglables par des articulations à rotule dirigent la lumière dans des positions diverses. Les surfaces intérieures peuvent être laquées sur demande dans d'autres couleurs plus contrastées. ■ Alluminio, vetroresina. Lampada da soffitto per l'incasso in controsoffitti, profondità di montaggio 15 cm. Misure speciali su richiesta. Grazie a riflettori Multi Mirror regolabili tramite giunti sferici, la luce può essere diretta in varie posizioni. Le superfici interne possono essere verniciate in altri colori contrastanti su richiesta. ■ Aluminio, cable de fibra de vidrio. Lámpara de techo para colgarla, profundidad de montaje min. 15 cm. Medidas especiales por encargo. Reflectores Multi Mirror ajustables gracias a su articulación esférica, la luz se puede dirigir en diferentes direcciones. Posibilidad de lacar las superficies interiores en otros colores por encargo.

3 x max. 50 W Halogen GU 5,3 12 V

CDM version and special sizes of 250 cm and larger on request

Light Cone L Ingo Maurer 2005

Fibreglas. Für fugenlosen Einbau in abgehängte Decken, Einbautiefe 23 cm. CDM-Version nur für 230 Volt: Einbautiefe 24 cm. Mit elektronischem Vorschaltgerät. Lieferung mit Leuchtmittel. ■ Fibreglass. For flush mounting in lowered ceilings, installation depth 23 cm. CDM version for 230 volts only: installation depth 24 cm. With integrated electronic ballast. Complete with bulb. ■ Fibre de verre. Pour montage sur plafonds surbaissés. Profondeur pour montage 23 cm. Version CDM seulement en 230 volts: Profondeur 24 cm. Avec ballast électronique. Livrée avec ampoule. ■ Vetroresina. Per l'incasso in controsoffitti. Profondità di montaggio 23 cm. Versione CDM solo in 230 volt: Profondità di montaggio 24 cm. Alimentatore elettronico incluso. Lampadina inclusa. ■ Fibra de vidrio. Para una instalación libre de juntas en falsos techos. Profundidad de montaje 23 cm. Versión CDM sólo para 230 voltios: profundidad de montaje 24 cm de largo. Con balastro electrónico. Suministrada con bombilla.

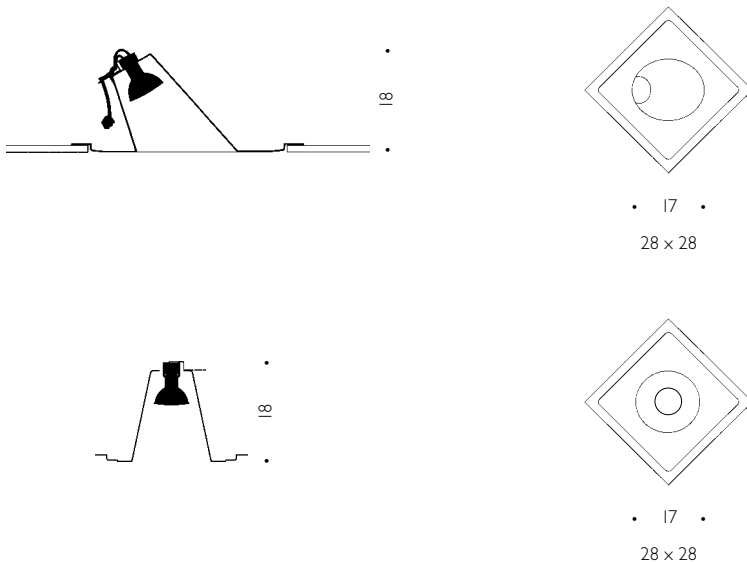


💡 max. 100 W 24° Halogen G53 ⚡ 12 V

💡 CDM version: 230 V only, max. 35 W 24° GX 8,5

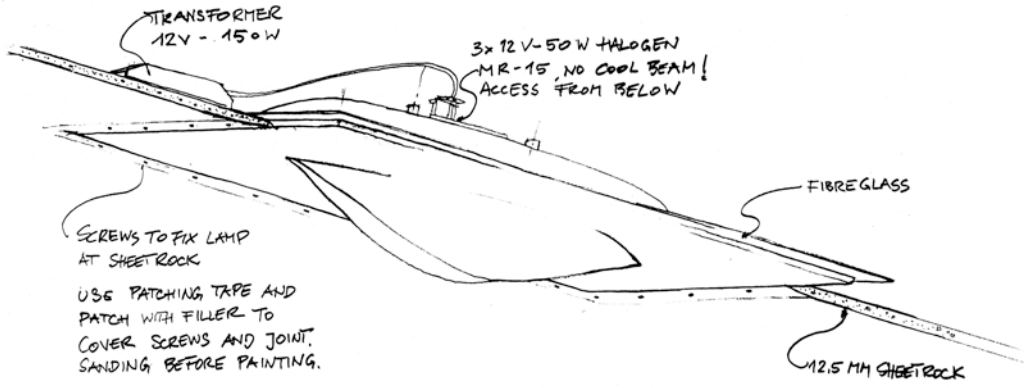
Light Cone S / Light Cone S vertical Ingo Maurer 2005

Fibreglas. Für fugenlosen Einbau in abgehängte Decken, Einbautiefe 18 cm. Lieferung mit Leuchtmittel. ■ Fibre-glass. For flush mounting in lowered ceilings. Installation depth 18 cm. Complete with bulb. ■ Fibre de verre. Pour montage sur plafonds surbaissés. Profondeur pour montage 18 cm. Livrée avec ampoule. ■ Vetroresina. Per l'incasso in controsoffitti. Profondità di montaggio 18 cm. Lampadina inclusa. ■ Fibra de vidrio. Para una instalación libre de juntas en falsos techos. Profundidad de montaje 18 cm. Suministrada con bombilla.

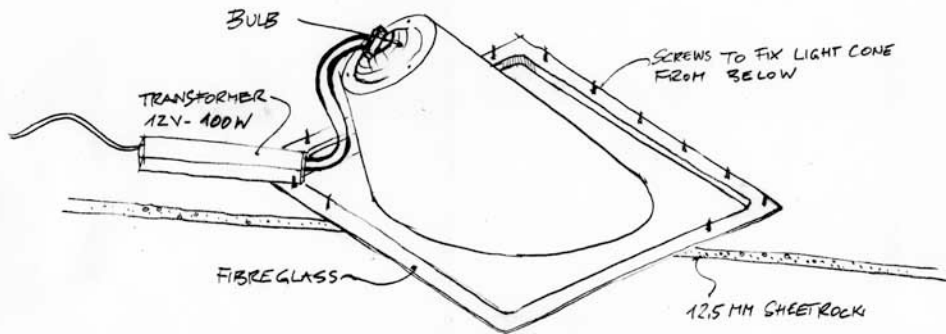


💡 max. 75 W 25° Halogen GU 10

SCHLITZ UP
VIEW FROM BELOW INTO OPEN RECESSED CEILING



LIGHT CONE
PERSPECTIVE VIEW INTO RECESSED CEILING

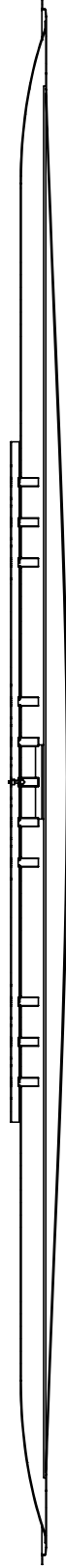
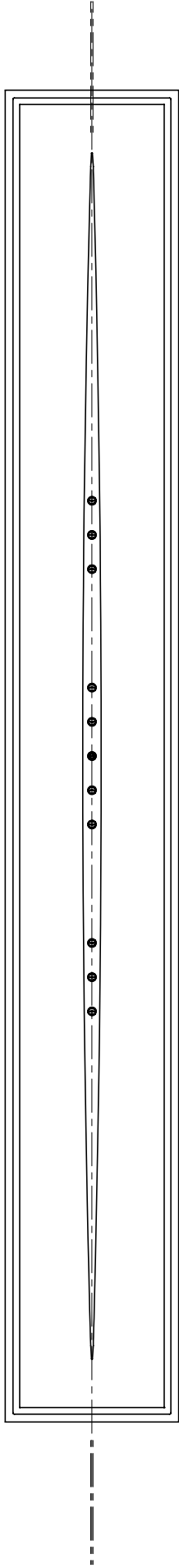




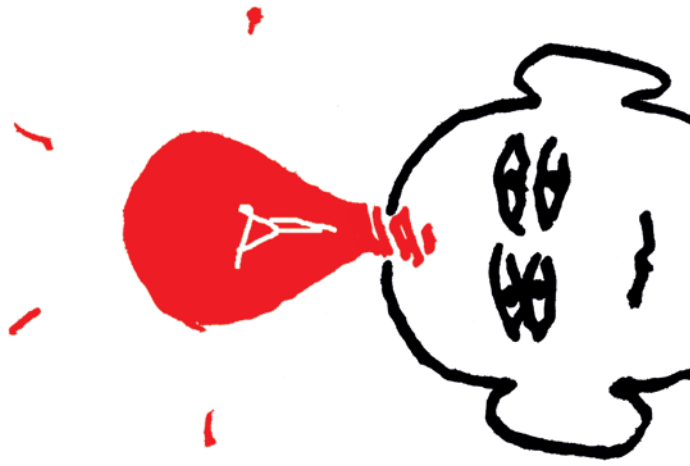
Schlitz Up, custom colour

my answer to boring
downlights:
'Schlitz Up'! Just an elegant
cut in the ceiling.

250 or 450 x 50 cm. Custom sizes available on request.







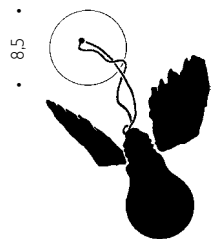
Wandlampen / Wall lamps / Appliques / Lampade da parete / Apliques



Lucellino Ingo Maurer 1992

Glas, Messing, Kunststoff, handgefertigte Flügel aus Gänsefedern. Transformator erforderlich. Lieferung mit Ersatzglühlampe und weißer Abdeckscheibe Ø 8,5 cm. Nicht geeignet für Räume mit hoher Luftfeuchtigkeit. ■ Glass, brass, plastic, hand-crafted goosefeather wings. Transformer required. Complete with spare bulb and white base-plate Ø 8,5 cm. Not suited for rooms with high humidity. ■ Verre, laiton, matière plastique, ailes confectionnées à la main en plumes d'oie. Transformateur obligatoire. Livrée avec une ampoule de rechange et une rondelle de recouvrement blanche Ø 8,5 cm. N'est pas appropriée pour des pièces avec un fort taux humidité. ■ Vetro, ottone, materiale sintetico, ali in piume d'oca lavorate a mano. E' necessario un trasformatore. Lampadina di ricambio e piastra di copertura bianca Ø 8,5 cm incluse. Non adatta all'uso in ambienti con alta umidità. ■ Vidrio, latón, plástico, alas hechas a mano con plumas de oca. Requiere transformador. Suministrada con bombilla de recambio y cubierta blanca de Ø 8,5 cm. No apta para ambientes con un alto porcentaje de humedad.

24 V Halogen EU approved



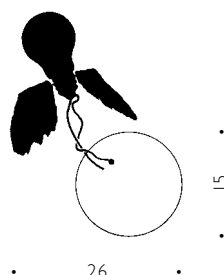
ca. 18



Lucellino NT Ingo Maurer 1992

Wandversion mit eingebautem Transformator. Aufputz-Montagedose und weiße Abdeckscheibe Ø 15 cm. Lieferung mit Ersatzglühlampe. Nicht geeignet für Räume mit hoher Luftfeuchtigkeit. ■ Wall version with built-in transformer. Surface-mounting box with white base-plate cover Ø 15 cm. Complete with spare bulb. Not suited for rooms with high humidity. ■ Version murale avec transformateur intégré. Avec boîtier pour montage sur crépi et rondelle de recouvrement blanche Ø 15 cm. Livrée avec ampoule de rechange. N'est pas appropriée pour des pièces avec un fort taux humidité. ■ Versione da parete con trasformatore integrato. Con scatola di derivazione esterna e piastra di copertura bianca Ø 15 cm. Lampadina di ricambio inclusa. Non adatta all'uso in ambienti con alta umidità. ■ Versión de pared con transformador integrado. Caja para montaje con cubierta blanca de Ø 15 cm. Suministrada con bombilla de recambio. No es apta para ambientes con un alto porcentaje de humedad.

24V Halogen EU approved





Seven off the Wall Ingo Maurer und Team 2010

Technische Angaben wie Birdie's Busch, Seite 126. ■ Technical details see Birdie's Busch, page 126. ■ Détails techniques comme Birdie's Busch, page 126. ■ Dettagli tecnici come Birdie's Busch, pagina 126. ■ Datos técnicos como Birdie's Busch, página 126.

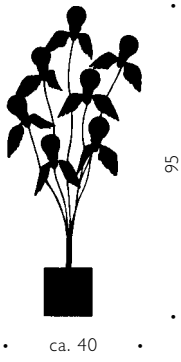
24 V Halogen EU approved



Twelve off the Wall *Ingo Maurer und Team 2010*

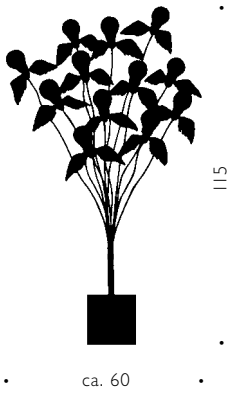
Technische Angaben wie Birdie's Busch, Seite 126. ■ Technical details see Birdie's Busch, page 126. ■ Détails techniques comme Birdie's Busch, page 126. ■ Dettagli tecnici come Birdie's Busch, pagina 126. ■ Datos técnicos como Birdie's Busch, página 126.

24V Halogen EU approved



Seven off the Wall

max. 70 W Halogen E27 transformer 24 V



Twelve off the Wall

max. 120 W Halogen E27 transformer 24 V

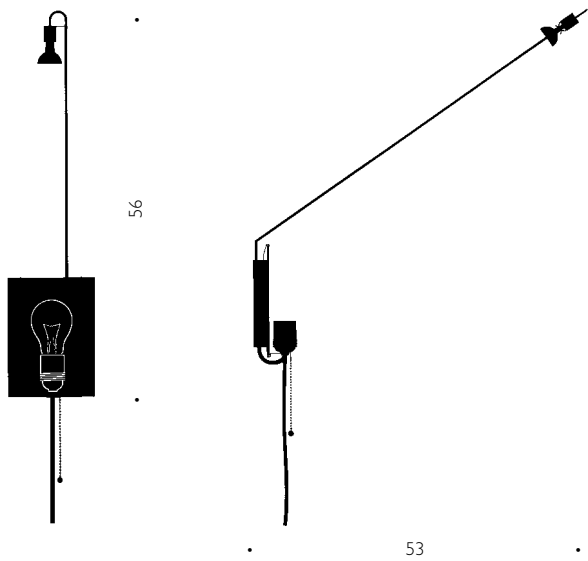


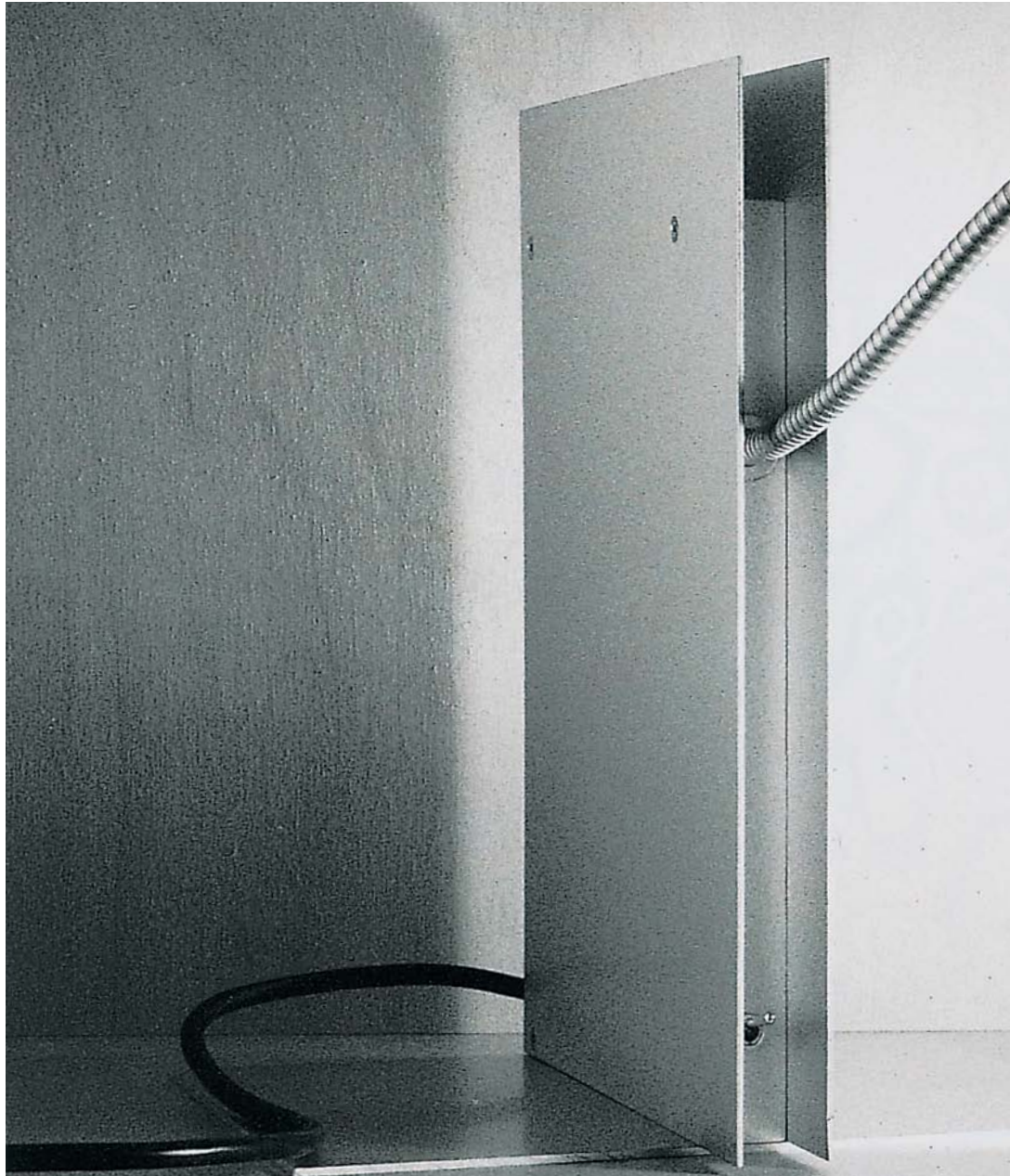


Holonzki

Holonzki / Dead Bulb Alive* Eckard Knuth, Ingo Maurer 2000

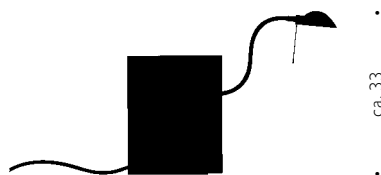
Glas-Hologramm 13 x 18 cm, Metall, schwarzes Textilkabel. Auswahl/Festlegung der Hologrammfarbe aus technischen Gründen nicht möglich. Lieferung mit Leuchtmittel. Direkte Sonneneinstrahlung und Nikotin können die Lebensdauer des Hologramms reduzieren. ■ Glass hologram 13 x 18 cm, metal, black fabric cable. For technical reasons, customer choice of hologram colour is not possible. Complete with bulb. Direct sunlight and nicotine may reduce the hologram's life span. ■ Hologramme en verre 13 x 18 cm, métal, câble de textile noir long de 250 cm. Pour des raisons techniques, le choix de la couleur de l'hologramme n'est pas possible. Livrée avec ampoule. Une exposition directe au soleil et à la nicotine peut réduire la durée de vie de l'hologramme. ■ Ologramma in vetro cm. 13 x 18, metallo, cavo tessile nero. Per ragioni tecniche non è possibile la scelta del colore dell'ologramma. Lampadina inclusa. L'esposizione diretta al sole e alla nicotina possono ridurre la durata dell'ologramma. ■ Holograma en el vidrio 13 x 18 cm, cable textil negro. La selección de color del holograma no es posible por razones técnicas. Suministrada con bombilla. La exposición directa a los rayos del sol y la nicotina pueden reducir la vida útil del holograma.





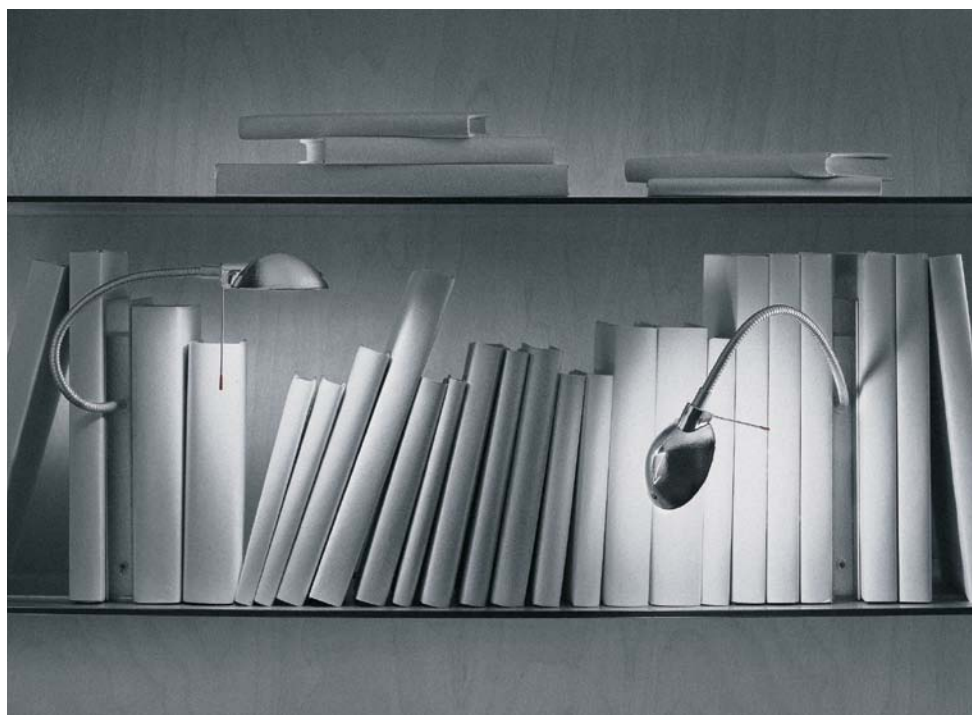
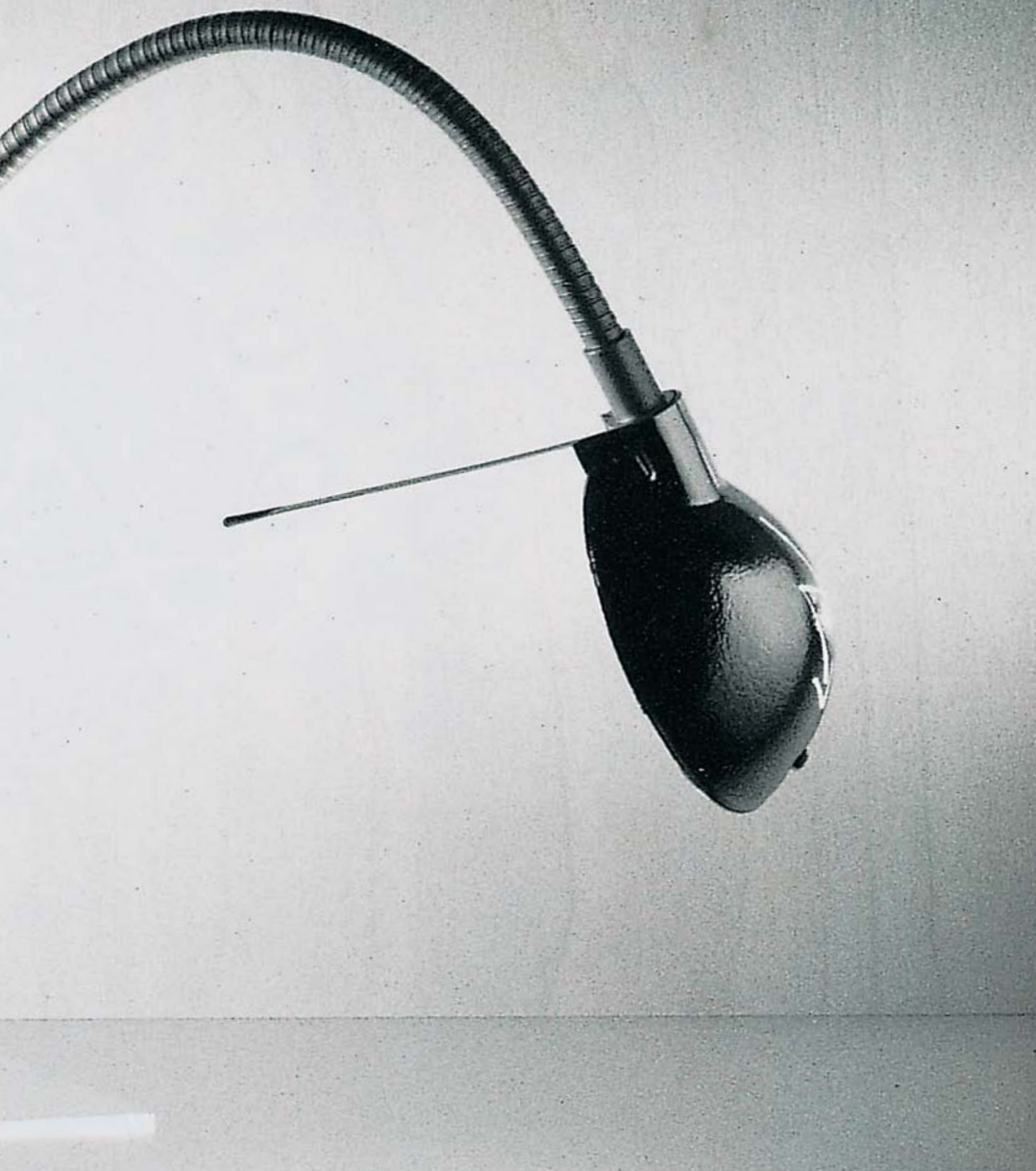
Oskar Ingo Maurer 1998

Metall, eloxiertes Aluminium, Reflektor mit Schutzglas. Transformator mit integriertem Kippschalter. Ein flexibler Metallarm ermöglicht die variable Einstellung des Reflektors. Lieferung mit Leuchtmittel. ■ Metal, anodized aluminium, reflector with protective glass cover. Transformer with integrated toggle switch. A flexible metal arm allows variable adjustment of the reflector. Complete with bulb. ■ Métal, aluminium anodisé, réflecteur avec verre protecteur. Transformateur avec interrupteur à bascule intégré. Un bras métallique flexible permet le réglage variable du réflecteur. Livrée avec ampoule. ■ Metallo, alluminio anodizzato, riflettore con vetro di protezione. Trasformatore con interruttore a levetta integrato. Un flessibile braccio metallico permette la regolazione variabile del riflettore. Lampadina inclusa. ■ Metal, aluminio anódico y reflector con cristal protector. Transformador con interruptor basculante integrado. Gracias a su brazo de metal flexible el reflector es ajustable a diferentes posiciones. Suministrada con bombilla.



ca. 33

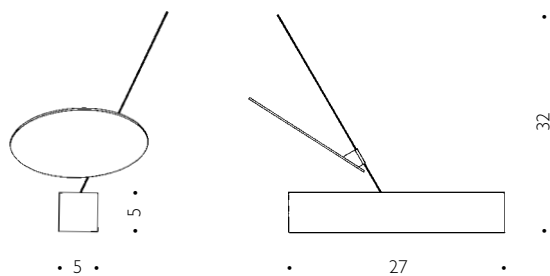
• 19 •

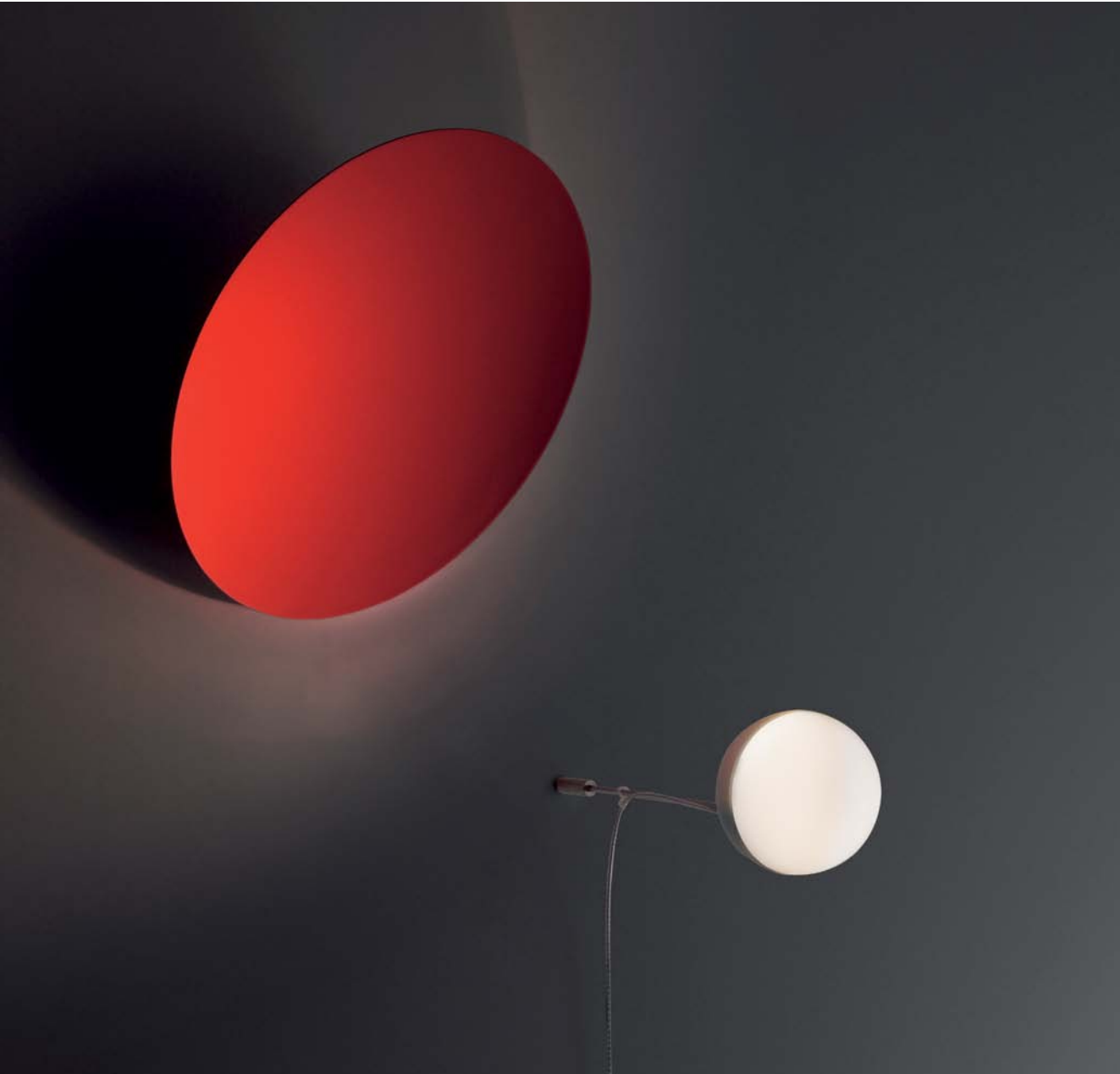




zero-one Ingo Maurer und Team 1990

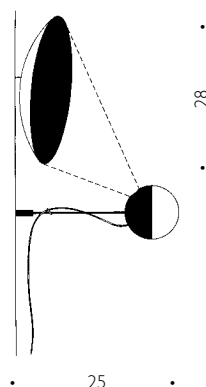
Weißes Corian, mattierter Spiegel. Der bewegliche Spiegel dient zur Lichtumlenkung. Lieferung mit Leuchtmittel. ■ Corian, white, frosted mirror. The direction of the light can be altered by adjusting the position of the mirror. Complete with bulb. ■ Corian blanc, miroir mat. Le miroir mobile permet de modifier le faisceau lumineux. Livrée avec ampoule. ■ Corian bianco, specchio smerigliato. Lo specchio regolabile serve per indirizzare la luce. Lampadina inclusa. ■ Corian blanco, espejo mate. El espejo móvil sirve para desviar la luz. Suministrada con bombilla.





Aka_Tsuki Matthias Liedtke 2003

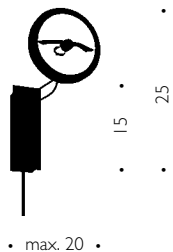
Metall, Glas. Aus einer Opalgaskugel Ø 8,5 cm angestrahlt, scheint eine rot pigmentierte Schale räumlich vor der Wand zu schweben. Lieferung mit Leuchtmittel. ■ Metal, glass. Illumination comes from wall mounted opaline glass ball Ø 8,5 cm, a red-pigmented bowl seems to be floating three-dimensionally on the wall. Complete with bulb. ■ Métal, verre. Eclairée par une sphère opaline, Ø 8,5 cm, une soucoupe pigmentée de rouge semble flotter en trois dimensions devant le mur. Livrée avec ampoule. ■ Metallo, vetro. Illuminata da una sfera opalina, Ø 8,5 cm, un piatto colorato rosso sembra galleggiare tridimensionalmente davanti alla parete. Lampadina inclusa. ■ Metal, vidrio. Iluminada a través de una esfera de vidrio opalino de Ø 8,5 cm, aparece un platillo de pigmentación roja flotando delante de la pared. Suministrada con bombilla.





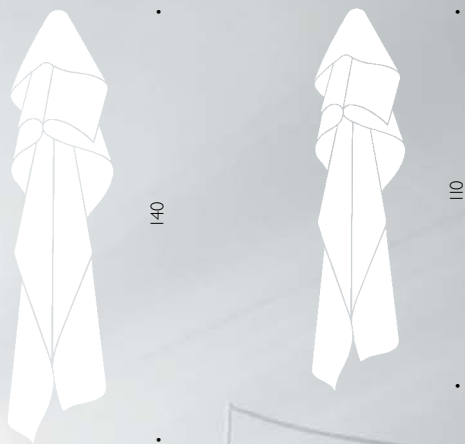
Use Me W. Ingo Maurer 2010

Edelstahl, Aluminium. Der Strahler ist über zwei Kugelgelenke einstellbar. Transparentes Kabel mit Schalter. Mit integriertem elektronischen Transformator. Das Leuchtmittel ist im Handel auch in anderen Ausstrahlungswinkeln und Wattagen erhältlich. Lieferung mit Leuchtmittel. ■ Stainless steel, aluminium. Adjustable via two ball-joints. Transparent cable with switch. Integrated electronic transformer. In trade the light source is also available with other angles and wattages. Complete with bulb. ■ Acier inoxydable, aluminium. Spot ajustable par deux articulations à rotule. Câble avec interrupteur, non dimmable. L'halogène est aussi disponible en magasin avec autres angles et wattages. Livrée avec transformateur électronique intégré et ampoules. ■ Acciaio inossidabile, alluminio. Il faretto è regolabile mediante due giunti a sfera. Cavo con interruttore, non dimmerabile. Trasformatore elettronico integrato. La lampadina è anche disponibile in commercio con altri angoli d'irradiazione e wattaggi. Lampadina inclusa. ■ Acero inoxidable, aluminio. El foco se puede ajustar gracias a una articulación esférica. Cable con interruptor, no regulable en intensidad. Transformador integrado. La bombilla también está disponible en comercio en otros ángulos del haz y potencias. Suministrada con bombilla.



 max. 100 W 8° Halogen G53
  12 V
  300 cm





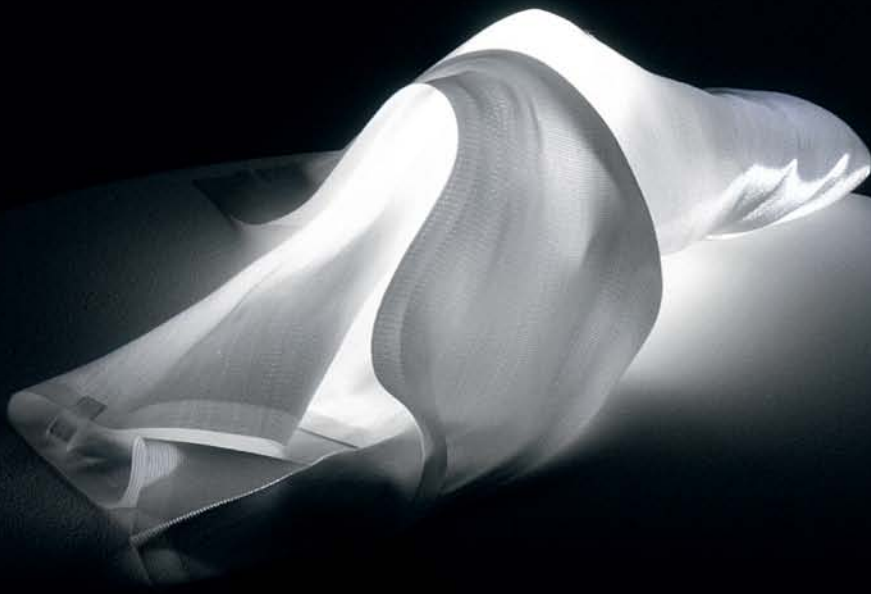
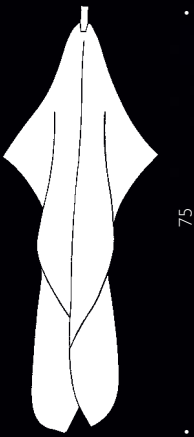
Santa Maria della Luce *Frans van Nieuwenborg 2006*

Hitzebeständiges Glasgewebe, Aluminium. Größe 1: Länge 110 cm, Größe 2: Länge 140 cm. 230-Volt-Version stufenlos dimmbar. Abnehmbare Farbfilter in Blau und Orange. Lieferung mit Leuchtmittel. ■ Heat-resistant glass fabric, aluminium. Size 1: length 110 cm, size 2: length 140 cm. 230 volts version continuously dimmable. Detachable colour filters in blue and orange. Complete with bulb. ■ Tissu de verre thermorésistant, aluminium. Longueur 1: 110 cm, longueur 2: 140 cm. Version 230 volts: avec intensité lumineuse variable en réglage continu. Écrans de couleur bleue et orange détachables. Livrée avec ampoule. ■ Tessuto in fibra di vetro termoresistente, alluminio. Misura 1: lunghezza 110 cm, misura 2: lunghezza 140 cm. Versione da 230 volt: Regolazione continua dell'intensità luminosa. Filtri rimovibili di colore blu e arancione. Lampadina inclusa. ■ Material de vidrio termoestable, aluminio. Medidas 1: largo 110 cm, medidas 2: largo 140 cm. Versión de 230 voltios con regulador de intensidad incluido. Filtro desmontable en color azul y naranja. Suministrada con bombilla.

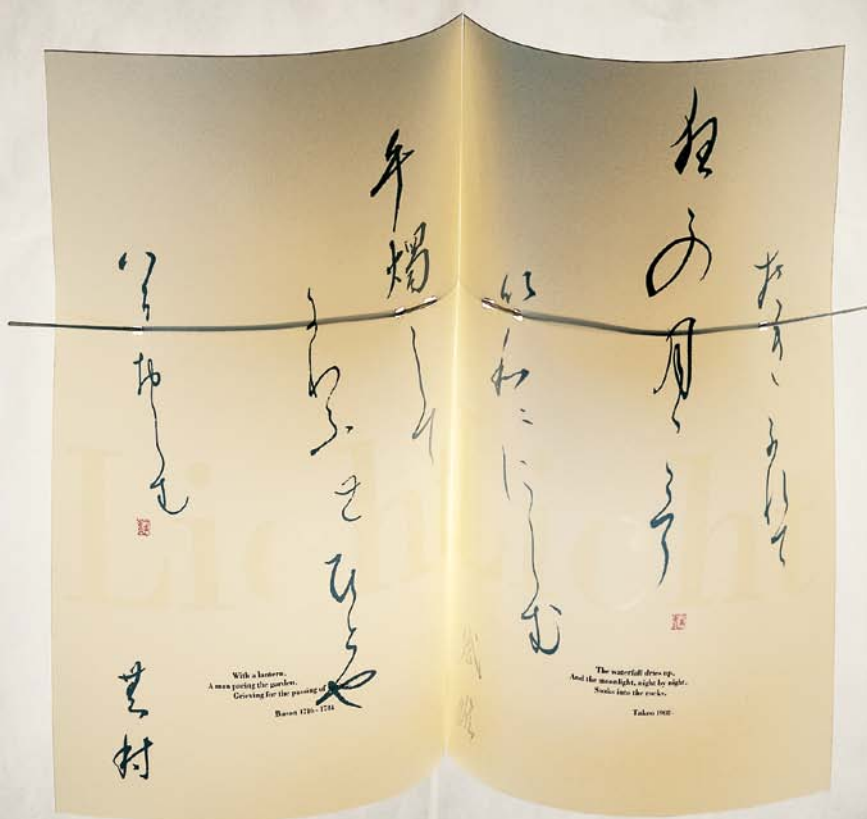


Delight Frans van Nieuwenborg, Martijn Wegman 1980

Hitzebeständiges Glasgewebe, Dauerbelastung bis 180° C möglich. Tuchformat 75 x 75 cm. Lieferung ohne Glühlampe. ■ Heat-resistant glass fabric. Capable of withstanding continuous use at temperatures of up to 180° C. Cloth size 75 x 75 cm. Bulb not included. ■ Fibre de verre résistant à la chaleur, supporte une chaleur continue jusqu'à 180°C max. Format du tissu en fibre de verre 75 x 75 cm. Livrée sans ampoule. ■ Tessuto in fibre di vetro termoresistente. Sostiene calore continuo fino a 180°C. Misura del tessuto cm. 75 x 75. Lampadina non inclusa. ■ Tejido de vidrio termoestable, soporta una carga continua de hasta 180°C. Formato del tejido 75 x 75 cm. Suministrada sin bombilla.

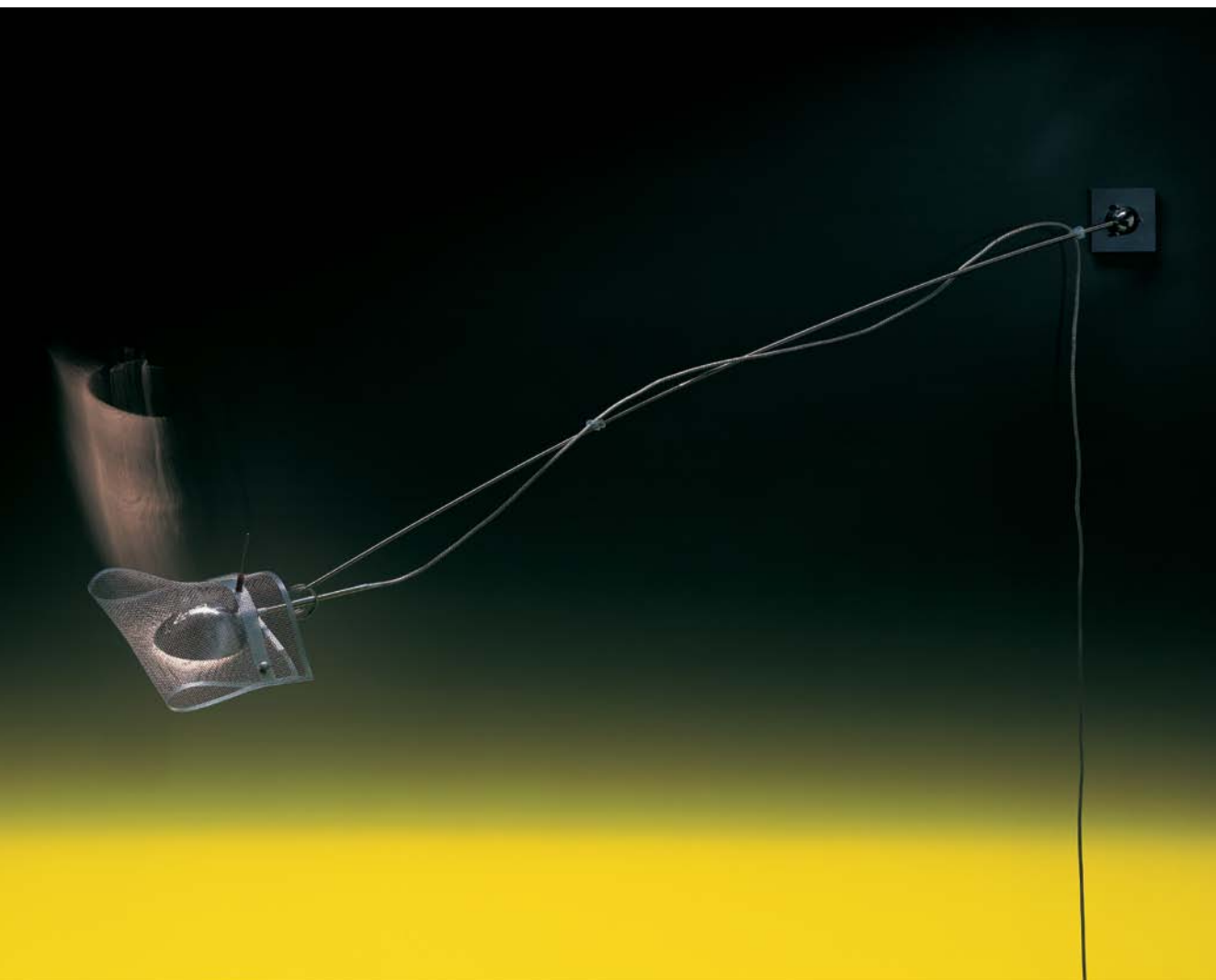






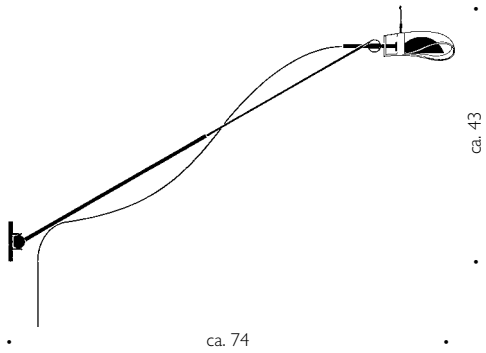
Licht Licht Reyner Kras 1993

Ecklampe aus Federdraht und 2 Lexanfolien. Bevorzugte Platzierung in einer Raumecke. Licht Licht wird mit 4 Folien geliefert: 2 Blätter mit einem Haiku-Vers in japanisch und englisch, 2 Blätter ohne Text. Nach dem Löschen des Lichts erscheint auf den Folien der Name „Licht Licht“ als fluoreszierender Schriftzug. Lieferung ohne Glühlampe. ■ Wire frame with 2 Lexan films. Particularly suited for corner lighting. Supplied with four sheets of films: two blank and two inscribed with a haiku in Japanese and English. When the light goes off, the name “Licht Licht” appears in fluorescent characters on the films. Bulb not included. ■ Applique d’angle avec tiges métalliques flexibles et 2 feuilles en Lexan. Emplacement idéal à l’angle d’une pièce. Licht Licht est livrée avec 4 feuillets: 2 pages avec un vers haiku en japonais et en anglais, 2 pages sans texte. Une fois la lumière éteinte, le nom «Licht Licht» apparaît en caractères fluorescents sur les feuillets. Livrée sans ampoule. ■ Lampada da angolo con stelo flessibile e 2 fogli Lexan. Si può posizionare ad angolo. Licht Licht viene fornita con 4 fogli: 2 fogli con un poema Haiku in giapponese e inglese, 2 fogli senza testo. Dopo aver spento la luce sui fogli appare il nome «Licht Licht» in lettere fluorescenti. Lampadina non inclusa. ■ Lámpara en ángulo realizada en alambre flexible y 2 láminas Lexan. Ubicar preferentemente en una esquina de la habitación. Licht Licht se suministra con 4 láminas. 2 láminas con un verso Haiku en japonés e inglés, 2 láminas sin texto. Al apagar la luz aparece sobre las láminas el nombre «Licht Licht» como inscripción fluorescente. Suministrada sin bombilla.



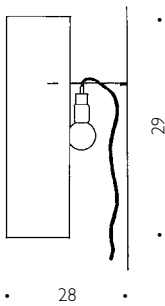
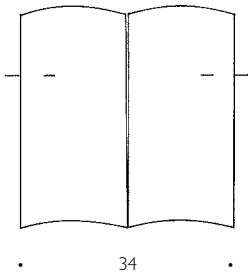
Los MinimalosTres Ingo Maurer und Team 1994

Edelstahl, Stahlgewebe und Aluminium. Ein Kugelgelenk ermöglicht Drehen und Neigen in jede Richtung. Der Teleskoparm ist beweglich und von 40 auf 75 cm ausziehbar, die Neigung des Reflektors variabel. Los Minimalos Tres ist auch für die Montage an Möbeln und als Bilderleuchte geeignet. Lieferung mit Leuchtmittel. ■ Stainless steel, steel mesh and aluminium. The ball-and-socket joint enables the lamp to be tilted and swivelled in any direction. The movable telescope arm extends from 40 to 75 cm, and the reflector angle is also adjustable. Also suitable for attachment to furniture or for use as picture lighting. Complete with bulb. ■ Acier inoxydable, fibre d'acier et aluminium. Une articulation à rotule permet de tourner et d'incliner la lampe dans toutes les directions. Le bras télescopique est mobile et s'étend de 40 à 75 cm, l'inclinaison du réflecteur est variable. Los MinimalosTres permet également un montage sur des meubles et est utilisable comme éclairage de tableaux. Livrée avec ampoule. ■ Acciaio inossidabile, alluminio e tessuto in acciaio. Ruotabile e inclinabile in ogni direzione mediante un giunto sferico. Il braccio telescopico è mobile e allungabile da cm. 40 a cm. 75, l'inclinazione del riflettore è variabile. Los Minimalos Tres è adatta anche per il montaggio su mobili e per l'illuminazione di quadri. Lampadina inclusa. ■ Acero inoxidable, tejido de acero y aluminio. Una articulación permite el giro y la inclinación en todas las direcciones. El brazo telescópico es móvil y puede extenderse de 40 a 75 cm, la inclinación del reflector es variable. Los MinimalosTres es apto también para el montaje en muebles y como iluminación para cuadros. Suministrada con bombilla.



Los MinimalosTres

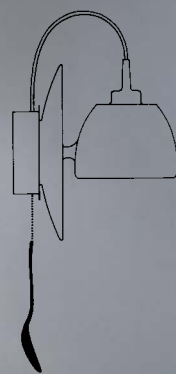
max. 50 W Halogen GY6,35 transformer 12 V
 cable 300 cm



Licht Licht

max. 40 W E14 cable 300 cm





32

15

Light au Lait Fabien Dumas, Ingo Maurer und Team 2004

Steingut, Silikon, Edelstahl. Durch Kugelgelenk um 180° drehbar und um 30° verstellbar. Eingebauter Zugschalter mit Löffel. Mit Aufputz-Montagedose. Die Montage ist auch auf Unterputzdose möglich. Lieferung mit Leuchtmittel. ■ Stoneware, silicone, stainless steel. The lamp swivels through 180° and can be bent down up to 30° by means of a ball joint. Integrated pull switch with spoon. Including surface-mounting box. Flush-mounted installation is also possible. Complete with bulb. ■ Faïence, silicone, acier inoxydable. Rotative et inclinable respectivement de 180° et 30° par une articulation à bille. Interrupteur à tirette intégré dans la cuillère. Avec boîtier pour montage sur crépi. Le montage sur boîtier sous crépi est également possible. Livrée avec ampoule. ■ Maiolica, silicone, acciaio inossidabile. Orientabile di 180° e inclinabile di 30° mediante un giunto sferico. Interruttore a catenella con cucchiaino. Con scatola di derivazione esterna. È possibile il montaggio ad una scatola di derivazione incassata. Lampadina inclusa. ■ Loza, silicona, acero inoxidable. La articulación permite un giro de 180° y un cambio de posición de 30°. Interruptor de tiro con cuchara. Incluye caja de montaje. El montaje también posible también en una caja debajo del revoque. Suministrada con bombilla.



Canned Light Christoph Matthias, Hagen Szezech 2003

Aluminium, Edelstahl, Kunststoff. Eine Konservendose, befüllt mit Glühlampe, Reflektor, Fassung, Kabel und Schalter wird zur Hänge- oder Wandlampe. Aufputz-Montage mit Abdeckscheibe weiß Ø 8 cm. Stufenlos höhenverstellbar durch Umlenkrolle und Justier-ring. ■ Aluminium, stainless steel, plastic. A tin can, containing lightbulb, reflector, socket, cable and switch, turns into a hanging or wall lamp. Surface-mounted ceiling fixture with white baseplate cover Ø 8 cm. Height freely adjustable with pulley and ring. ■ Aluminium, acier inoxydable, matière plastique. Une boîte de conserves, contenant ampoule, réflecteur, douille, câble, interrupteur se transforme en suspension ou applique. Montage sur crépi avec rondelle blanche de recouvrement Ø 8 cm. Réglable en hauteur sans graduation par poulie de renvoi et anneau coulissant. ■ Alluminio, acciaio inossidabile, materiale sintetico. Un barattolo da conserva, contenente lampadina, portalampada, riflettore, cavo e interruttore, si trasforma in una lampada a sospensione o da parete. Scatola di derivazione esterna con piastra bianca di copertura Ø 8 cm. Regolazione continua dell'altezza con carrucola e anello di bloccaggio. ■ Aluminio, acero inoxidable, plástico. una lata de conservas, relleno con bombilla, reflector y portalámpara, cable e interruptor se transforman en una lámpara colgante o de pared. Caja de montaje en el florón de Ø 8 cm. Ajuste gradual de la altura a través de una polea y un anillo de ajuste.

© 2003 and trademark by Campbell Soup Company used under license.
All rights reserved.





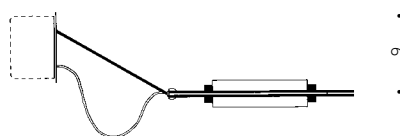
Bo-jek Ingo Maurer 1996

Aluminium, hitzebeständiges Glas. Deckenfluter zur Indirektbeleuchtung. Regelung der Lichtstärke über einen handelsüblichen Dimmer möglich. Mindestabstand zur Decke 50 cm. Lieferung mit Leuchtmittel. ■ Aluminium, heat-resistant glass. Uplighter for indirect light. A conventional dimmer may also be fitted. Minimum distance from ceiling 50 cm. Complete with bulb. ■ Aluminium, verre résistant à la chaleur. Applique pour éclairage indirect. Le réglage de l'intensité lumineuse est possible par l'emploi d'un variateur d'intensité, disponible dans le commerce. Distance minimum au plafond 50 cm. Livrée avec ampoule. ■ Alluminio, vetro termoresistente. Lampada da parete per un'illuminazione indiretta. L'intensità luminosa è regolabile mediante un dimmer in commercio. Distanza minima dal soffitto cm. 50. Lampadina inclusa. ■ Aluminio, vidrio termoestable. Proyector de techo para iluminación indirecta. Regulación de la intensidad luminosa a través de cualquier regulador dimmer del mercado. Distancia mínima con respecto al techo 50 cm. Suministrada con bombilla.



Wandering Finger Wall Ingo Maurer 1995

Edelstahl, eloxiertes Aluminium, hitzebeständiges Schutzglas. Der Reflektor ist über ein Kippgelenk verstellbar. Mit Leuchtmittel, Aufputz-Montagedose und aluminium-farbener Abdeckscheibe Ø 8 cm. Die Montage auf einer Unterputzdose ist ebenfalls möglich. ■ Stainless steel, anodized aluminium, heat-resistant protective glass cover: The ball-and-socket joint makes the reflector angle freely adjustable. Complete with bulb, surface-mounted ceiling fixture and aluminium-finish base-plate cover Ø 8 cm. Flush mounting also possible. ■ Acier inoxydable, aluminium anodisé, verre protecteur résistant à la chaleur. Le réflecteur est orientable par une articulation à bascule. Livrée avec ampoule, boîtier pour le montage sur crépi et rondelle de recouvrement de couleur aluminium Ø 8 cm. Possibilité de montage en applique. ■ Acciaio inossidabile, alluminio anodizzato, vetro di protezione termoresistente. Il riflettore è regolabile mediante un giunto basculante. Lampadina, scatola di montaggio e rosone di colore alluminio Ø cm. 8 inclusi. È possibile montarla anche su una scatola da incasso. ■ Acero inoxidable, aluminio galvanizado, vidrio protector termorresistente. El reflector puede reajustarse mediante una articulación en la base. Suministrada con bombilla, Incluye caja de montaje en el florón color aluminio de Ø 8 cm. También es posible montar sobre una caja debajo del revoque.





Max.Wall Ingo Maurer und Team 2001

Aluminium, Fiberglas, Edelstahl. Eingebauter Schalter. Reflektor um 180° drehbar. Mit Aufputz-Montagedose und Abdeckplatte 9 x 9 cm. Die Montage ist auch auf Unterputzdose möglich. Lieferung mit Leuchtmittel. ■ Aluminium, fibreglass, stainless steel. Built-in switch. Reflector rotates through 180°. With surface-mounted wall fixture and base-plate cover 9 x 9 cm. Flush-mounted installation is also possible. Complete with bulb. ■ Aluminium, fibre de verre, acier inoxydable. Interrupteur intégré. Réflecteur rotatif à 180°. Avec boîtier pour montage sur crépi et plaque de recouvrement 9 x 9 cm. Montage sur boîtier encastrable sous crépi possible. Livrée avec ampoule. ■ Alluminio, vetroresina, acciaio inossidabile. Interruttore integrato. Il riflettore ruota di 180°. Scatola di derivazione esterna con piastra di copertura 9 x 9 cm. È possibile il montaggio ad una scatola di derivazione incassata. Lampadina inclusa. ■ Aluminio, fibra de vidrio, acero fino. Interruptor incorporado. Reflector giratorio 180°. Incluye caja de montaje en el florón de 9 x 9 cm. El montaje se puede realizar bajo la caja protectora. Suministrada con bombilla.



Tooling *Christoph Matthias 2004*

Aluminium, Edelstahl, Kunststoff. Leuchtenkopf um 180° drehbar und um 45° schwenkbar. Der Reflektor ist matt grau lackiert. Aufputzmontage mit Abdeckscheibe Ø 8 cm. Die Montage ist auch auf Unterputzdose möglich. Lieferung mit Leuchtmittel. ■ Aluminium, stainless steel, plastic. Head of lamp rotates through 180° and tilts through 45°. The reflector has a mat grey finish. With surface-mounted wall fixture and base-plate cover Ø 8 cm. Flush-mounted installation is also possible. Complete with bulb. ■ Aluminium, acier inoxydable, matière plastique. Tête de lampe rotative à 180° et inclinable à 45°. Montage sur crépi avec rondelle de recouvrement Ø 8 cm. Montage sur boîtier encastrable sous crépi possible. Livrée avec ampoule. ■ Alluminio, acciaio inossidabile, materiale sintetico. Il riflettore ruota di 180° e si inclina di 45°. La superficie esterna del riflettore è verniciata grigio opaco. Scatola di derivazione esterna con piastra di copertura Ø 8 cm. È possibile il montaggio ad una scatola di derivazione incassata. Lampadina inclusa. ■ Aluminio, acero fino, plástico. La cabeza de la lámpara se puede girar hasta 180° e inclinarse hasta 45°. El reflector está lacado en color gris mate. Incluye caja de montaje en el florón de Ø 8 cm. También se puede montar empotrada. Suministrada con bombilla.



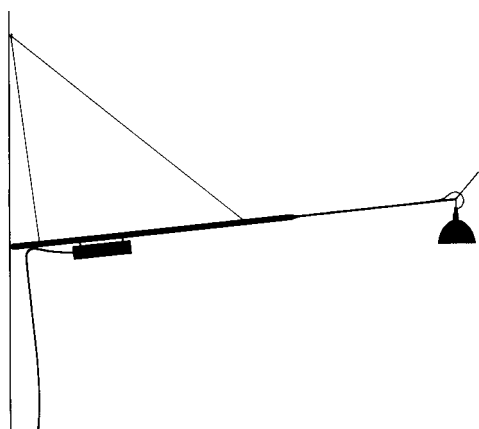


Max. Mover *Ingo Maurer und Team 2000*

Aluminium, Fiberglas. Das Teleskop ist von 110 auf 210 cm ausziehbar. Durch die Aufhängung an Nylonseilen ist Max. Mover in der Höhe zu verstellen und um 180° drehbar. An seinem Griff kann der Reflektor in zwei Richtungen stufenlos eingerichtet werden. Lieferung mit Leuchtmittel. ■ Aluminium, fibreglass. The telescopic arm extends from 110 to 210 cm, the nylon suspension wires allow for height adjustment and the lamp can be rotated through 180°. The reflector is freely adjustable in two directions, using the handle. Complete with bulb. ■ Aluminium, fibre de verre. Le télescope est extensible de 110 à 210 cm. Suspendu à des fils de nylon, Max. Mover est réglable en hauteur et rotatif à 180°. Grâce à sa poignée, le réflecteur peut être réglé sans graduation dans deux directions. Livrée avec ampoule. ■ Alluminio, vetroresina. Il braccio telescopico è allungabile da cm. 110 a cm. 210. Essendo sospesa a fili di nylon, Max. Mover è regolabile in altezza e ruota di 180°. Agendo sulla leva, il riflettore può essere regolato in continuo in due direzioni. Lampadina inclusa. ■ Aluminio, fibra de vidrio. El telescopio se puede ajustar entre los 110 cm y los 210 cm. La altura de la lámpara Max. Mover se puede regular en todo lo largo de los hilos de nylon de los que cuelga y se puede girar 180°. El reflector se puede ajustar en dos direcciones. Suministrada con bombilla.



One lamp, two uses: ceiling or wall.



• 110 • max. 100 •



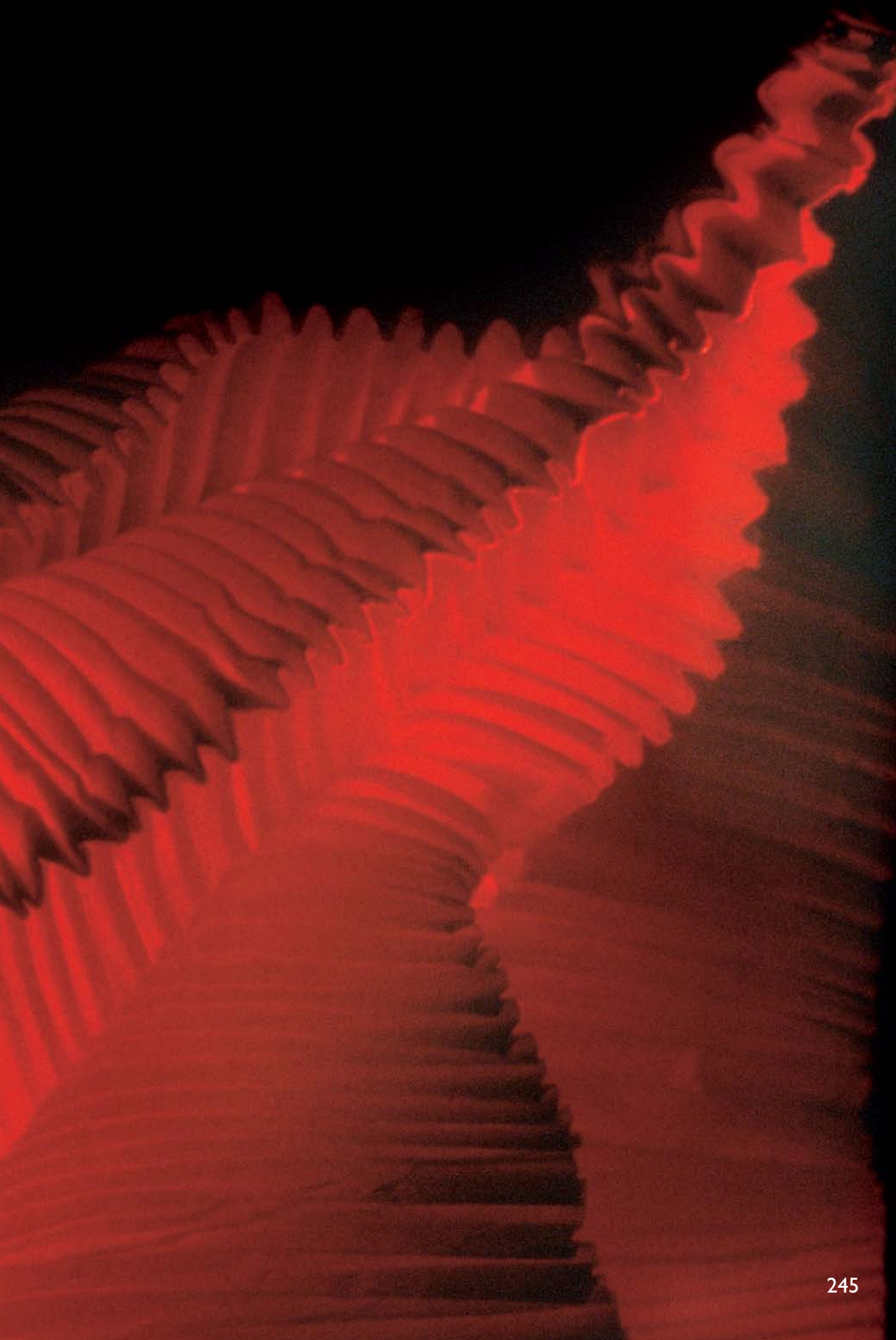
THE MA
M'D
NO
VCHIES

When Ingo Maurer encountered a textile sample made by Dagmar Mombach, it was love at first sight. For the MaMo Nouchies the concept was applied to the unique lightness and modesty of paper which has been one of his favourite materials for many years. Transformed by the elaborate process invented by Dagmar, the paper can be formed in a variety of new ways. Our aim has always been to make lighting that combines visual beauty with technical sophistication and this is exactly how we see The MaMo Nouchies®.

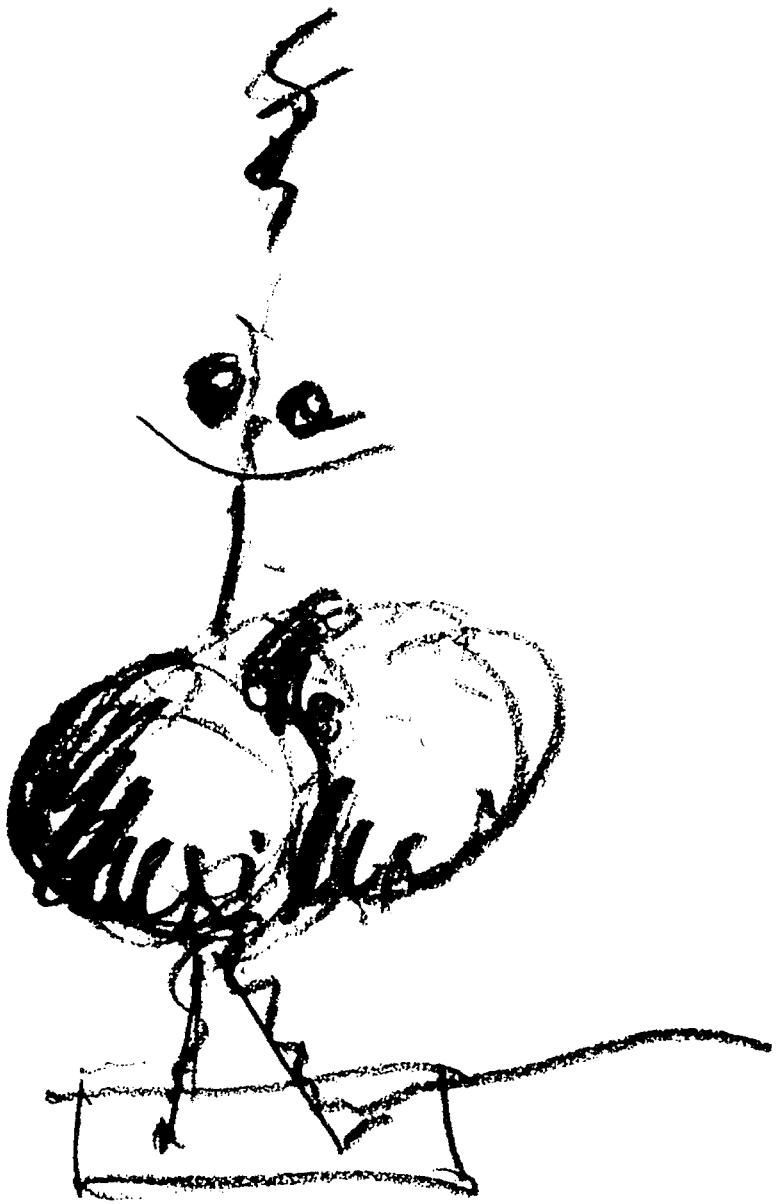
Als Ingo Maurer das erste Mal eine Probe des textilen Materials von Dagmar Mombach sah, verliebte er sich sofort. Für die MaMo Nouchies wurde der Bearbeitungsvorgang für Papier angepasst, das mit seiner einzigartigen Leichtigkeit und Bescheidenheit schon lange ein Lieblingsmaterial von Ingo Maurer ist. Verändert durch den aufwändigen Vorgang, den Dagmar weiterentwickelte, bietet das Papier eine Vielzahl von neuen gestalterischen Möglichkeiten. Unser Ziel war und ist es, Lampen zu machen, die visuelle Schönheit mit technischer Raffinesse verbinden, und genau als das sehen wir The MaMo Nouchies®.

The MaMoNouchies®

A New Tribe of Light



jealous of the moon



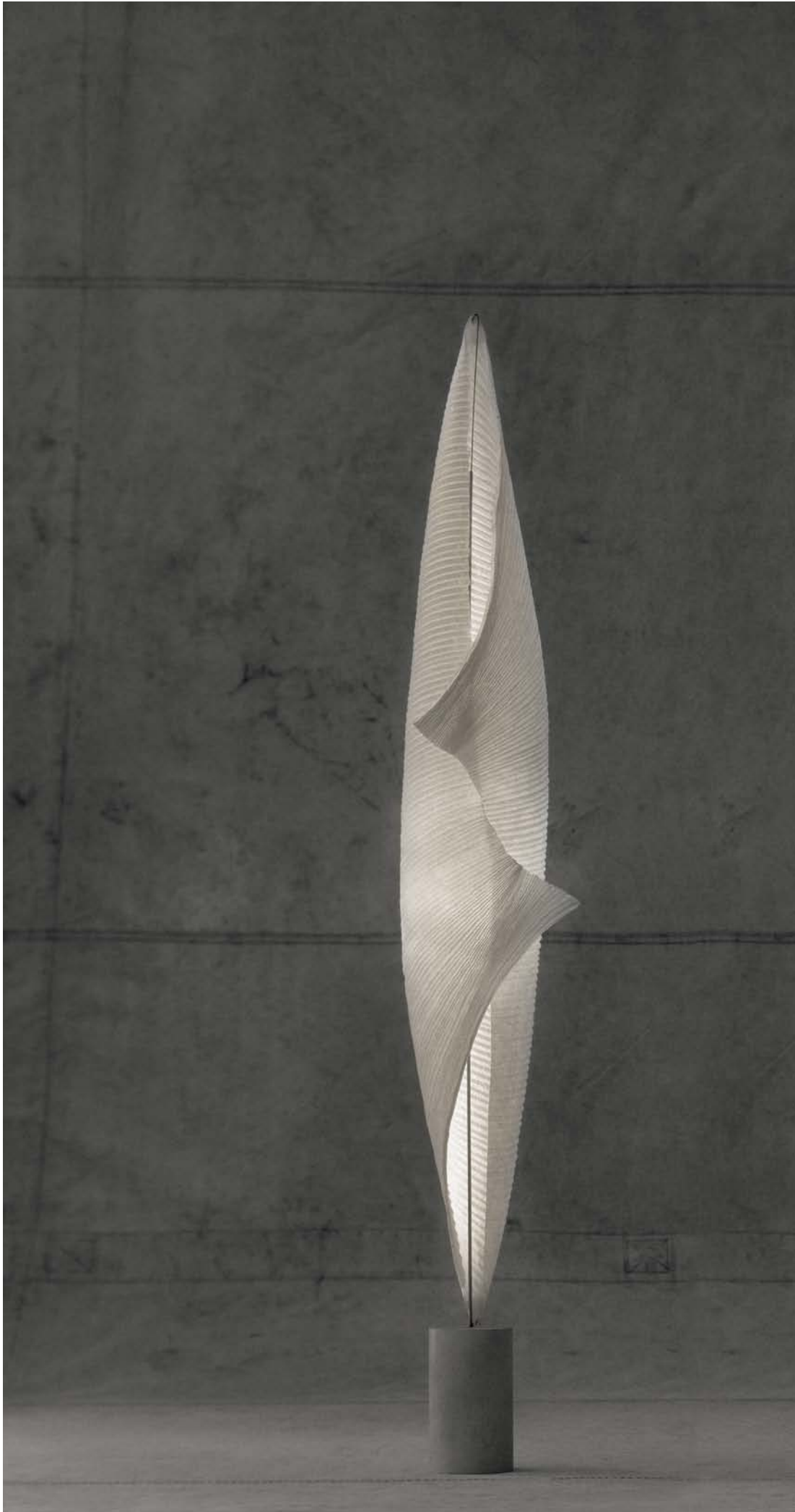


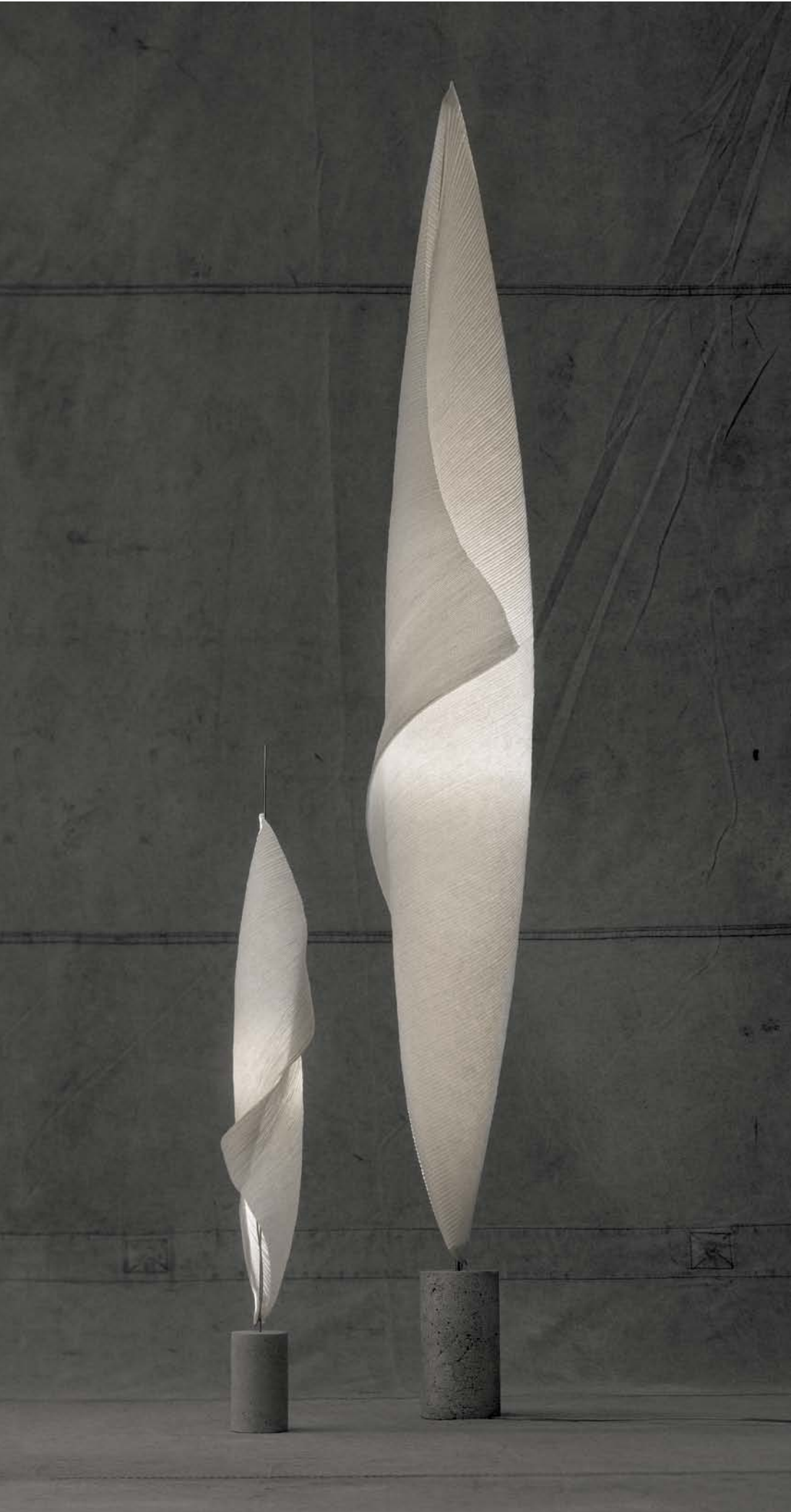
Kokoro *Dagmar Mombach, Ingo Maurer und Team 1998*

Rotes Papier, Metall, Edelstahl, Glas, Kunststoff. Verstellbarer Spiegel. Nicht geeignet für Räume mit hoher Luftfeuchtigkeit. Lieferung mit Leuchtmittel. ■ Red paper, metal, stainless steel, glass, plastic. Adjustable mirror. Not suited for rooms with high humidity. Complete with bulb. ■ Papier rouge, métal, acier inoxydable, verre, matière plastique. Miroir mobile. N'est pas appropriée pour des pièces avec un fort taux humidité. Livrée avec ampoule. ■ Carta rossa, metallo, acciaio inossidabile, vetro, materiale sintetico. Specchio orientabile. Non adatta all'uso in ambienti ad alta umidità. Lampadina inclusa. ■ Papel rojo, metal, acero fino, cristal, plástico. Espejo ajustable. No indicada para espacios húmedos. Suministrada con bombilla.



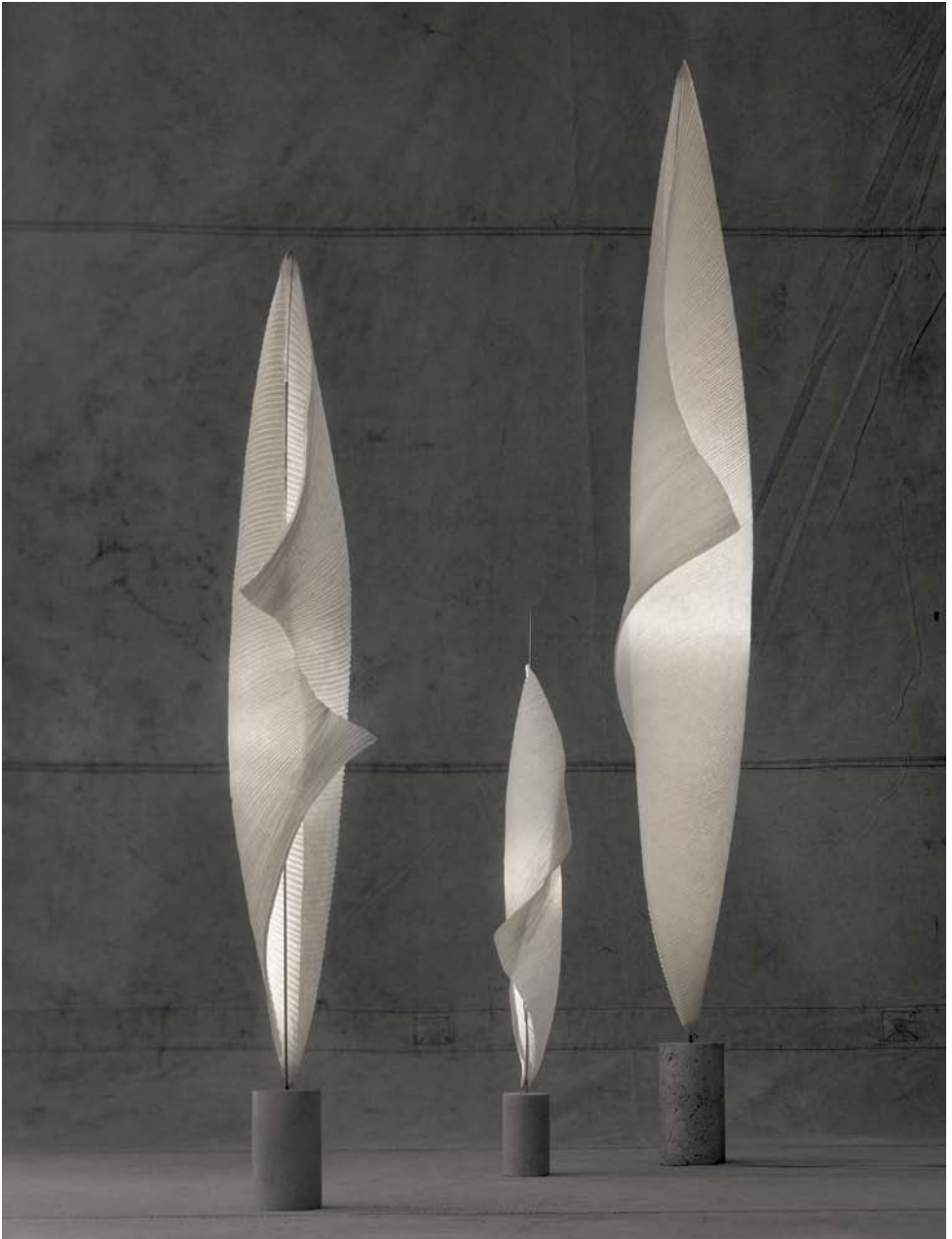
80





3

1



Wo-Tum-Bu 1 *Dagmar Mombach, Ingo Maurer und Team 1998*

Papier, Beton, Metall, Edelstahl, Kunststoff, Glasfaserblende. Mit Schiebedimmer. Lieferung mit Leuchtmittel. ■ Paper, concrete, metal, stainless steel, plastic, glassfibre shade. Dimmer with slide-control. Complete with bulb. ■ Papier, béton, métal, acier inoxydable, plastique, écran fibre de verre. Avec variateur à curseur. Livrée avec ampoule. ■ Carta, calcestruzzo, metallo, acciaio inossidabile, schermo in vetroresina. Con variatore lineare. Lampadina inclusa. ■ Papel, cemento, metal, acero fino, plástico, pantalla de fibra de vidrio. Regleta dimmer ajustable. Suministrada con bombilla.

 max. 150 W Halogen E27

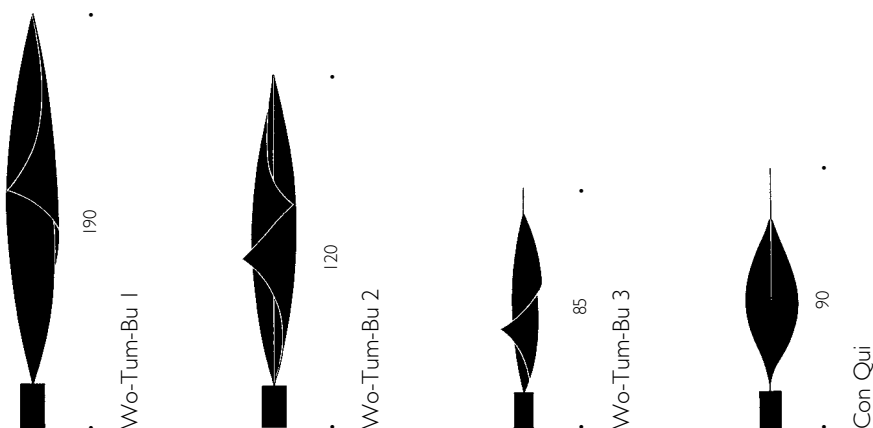
Wo-Tum-Bu 2 / Wo-Tum-Bu 3 *Dagmar Mombach, Ingo Maurer und Team 1998*

Papier, Beton, Metall, Edelstahl, Glasfaserblende/Glas. Lieferung mit Leuchtmittel. ■ Paper, concrete, metal, stainless steel, glass-fibre shade/glass. Complete with bulb. ■ Papier, béton, métal, acier inoxydable, écran fibre de verre/verre. Livrée avec ampoule. ■ Carta, calcestruzzo, metallo, acciaio inossidabile, materiale sintetico, schermo in vetroresina. Lampadina inclusa. ■ Papel, cemento, metal, acero fino, pantalla de fibra de vidrio/cristal. Suministrada con bombilla.



Con-Qui Dagmar Mombach, Ingo Maurer und Team 1998

Papier, Beton, Metall, Edelstahl, Kohlefaser, Silikon, Glasfaserblende. Lieferung mit Leuchtmittel. ■ Paper, concrete, metal, stainless steel, carbon-fibre, silicone, glassfibre shade. Complete with bulb. ■ Papier, béton, métal, acier inoxydable, fibre de carbone, silicone, écran fibre de verre. Livrée avec ampoule. ■ Carta, calcestruzzo, metallo, acciaio inossidabile, fibra di carbonio, silicone, schermo in vetroresina. Lampadina inclusa. ■ Papel, cemento, metal, acero fino, hilos de carbón, mampara de hilo de cristal. Suministrada con bombilla.



💡 max. 150 W

💡 max. 50 W Halogen GY 6,35 🔌 12 V



Jimken Dagmar Mombach, Ingo Maurer und Team 1998

Papier, Metall, Edelstahl, Silikon, Glas. Lieferung mit Leuchtmittel. ■ Paper, metal, stainless steel, silicone, glass. Complete with bulb. ■ Papier, métal, acier inoxydable, silicone, verre. Livrée avec ampoule. ■ Carta, metallo, acciaio inossidabile, silicone, vetro. Lampadina inclusa. ■ Papel, metal, acero fino, silicona, cristal. Suministrada con bombilla.





Ysmen Dagmar Mombach, Ingo Maurer und Team 1998

Papier, Metall, Edelstahl, Glas. Lieferung mit Leuchtmittel. ■ Paper, metal, stainless steel, glass. Complete with bulb. ■ Papier, métal, acier inoxydable, verre. Livrée avec ampoule. ■ Carta, metallo, acciaio inossidabile, vetro. Lampadina inclusa. ■ Papel, metal, acero fino, cristal. Suministrada con bombilla.

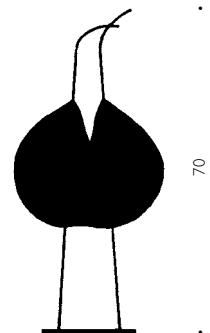


 max. 50 W Halogen GY 6,35  12 V



Poul Poul *Dagmar Mombach, Ingo Maurer und Team 1998*

Papier, Metall, Edelstahl, Silikon, Glas. Lieferung mit Leuchtmittel. ■ Paper, metal, stainless steel, silicone, glass. Complete with bulb. ■ Papier, métal, acier inoxydable, silicone, verre. Livrée avec ampoule. ■ Carta, metallo, acciaio inossidabile, silicone. Lampadina inclusa. ■ Papel, metal, acero fino, silicona, cristal. Suministrada con bombilla.





Samurai Dagmar Mombach, Ingo Maurer und Team 1998

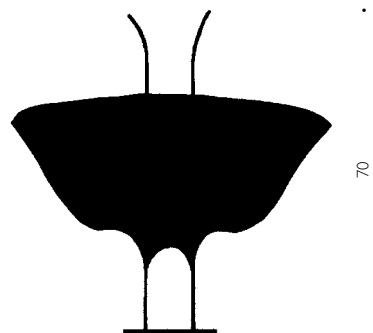
Papier, Metall, Edelstahl, Silikon, Glas, Glasfaserblenden. Lieferung mit Leuchtmittel.

■ Paper, metal, stainless steel, silicone, glass, glass-fibre shades. Complete with bulb. ■

Papier, métal, acier inoxydable, silicone, verre, écrans fibre de verre. Livrée avec ampoule.

■ Carta, metallo, acciaio inossidabile, silicone, vetro, schermi in vetroresina. Lampadina inclusa. ■

Papel, metal, acero fino, silicona, cristal, pantalla de fibra de vidrio. Suministrada con bombilla.

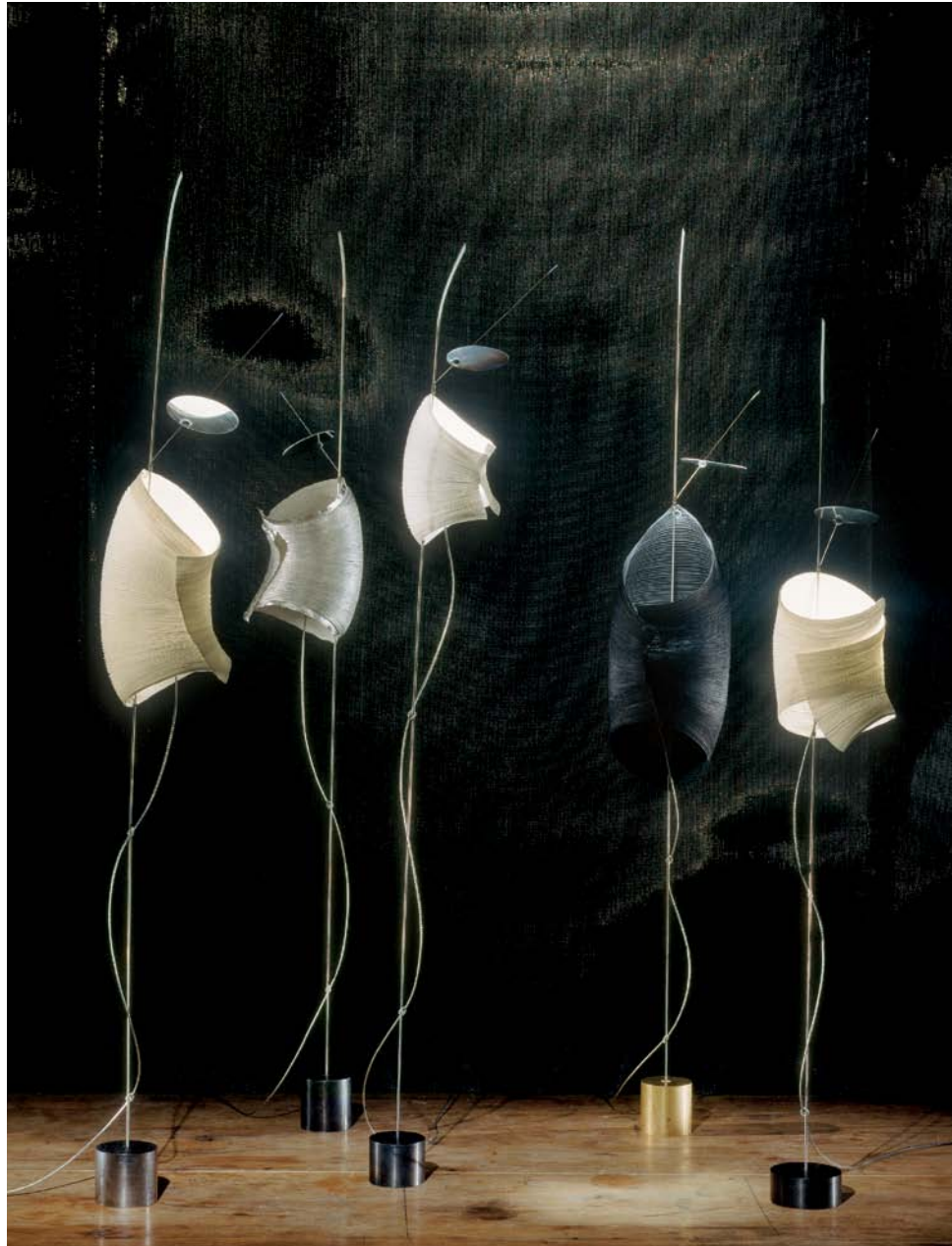


💡 max. 50 W Halogen GY 6,35 🔌 12 V



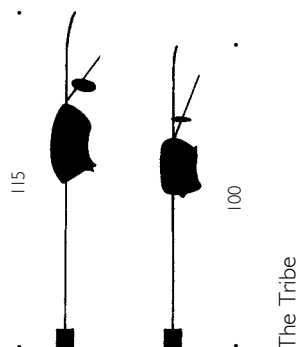
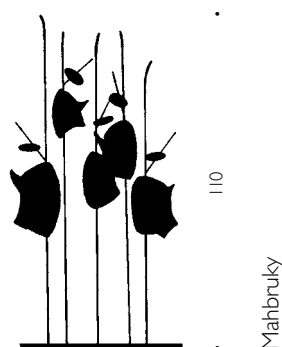
Mahbruky Dagmar Mombach, Ingo Maurer und Team 1998

Papier, Metall, Silikon, Glas, Aluminium, verstellbarer Spiegel. 230 Volt: Zwei elektronische Transformatoren, getrennt stufenlos dimmbar. 125 Volt: Transformator ohne Dimmer. Die Position der einzelnen Elemente ist variabel. Lieferung mit Leuchtmitteln. ■ Paper, metal, silicone, glass, aluminium, adjustable mirror. 230 volts: two electronic transformers, separately continuously dimmable. 125 volts: transformer without dimmer. Position of lighting elements is variable. Complete with bulbs. ■ Papier, métal, silicone, verre, aluminium. 230 volts: deux transformateurs électroniques, avec réglage d'intensité lumineuse séparé. 125 volts: transformateur sans réglage d'intensité lumineuse. La position des éléments individuels est variable. Livrée avec ampoules. ■ Carta, metallo, silicone, vetro, alluminio. 230 volt: Due trasformatori elettronici, regolabili separatamente. 125 volt: Trasformatore senza variatore. La posizione degli elementi è variabile. Lampadine incluse. ■ Papel, metal, silicon, cristal, aluminio, espejo ajustable. 230 voltios: dos transformadores electrónicos, reguladores separados. 125 voltios: transformador sin regulador. La posición de los elementos individuales es variable. Suministrada con bombilla.



TheTribe: Aikaduli / Watapunga Dagmar Mombach, Ingo Maurer und Team 1998

Fuß in Messing/Fuß in Stahl. Papier nur natur, Metall, Silikon, Glas, Aluminium, verstellbarer Spiegel. Lieferung mit Leuchtmittel. ■ Base in brass/base in steel. Paper natural only, metal, silicone, glass, aluminium, adjustable mirror. Complete with bulb. ■ Pied en laiton/pied en acier: Papier uniquement couleur nature, métal, silicone, verre, aluminium, miroir réglable. Livrée avec ampoule. ■ Base in ottone/base in acciaio. Carta solo di colore naturale, metallo, silicone, vetro, alluminio, specchio regolabile. Lampadina inclusa. ■ Pie de latón/pie de acero. Papel natural exclusivamente, metal, silicona, cristal, aluminio, espejo ajustable. Suministrada con bombilla.



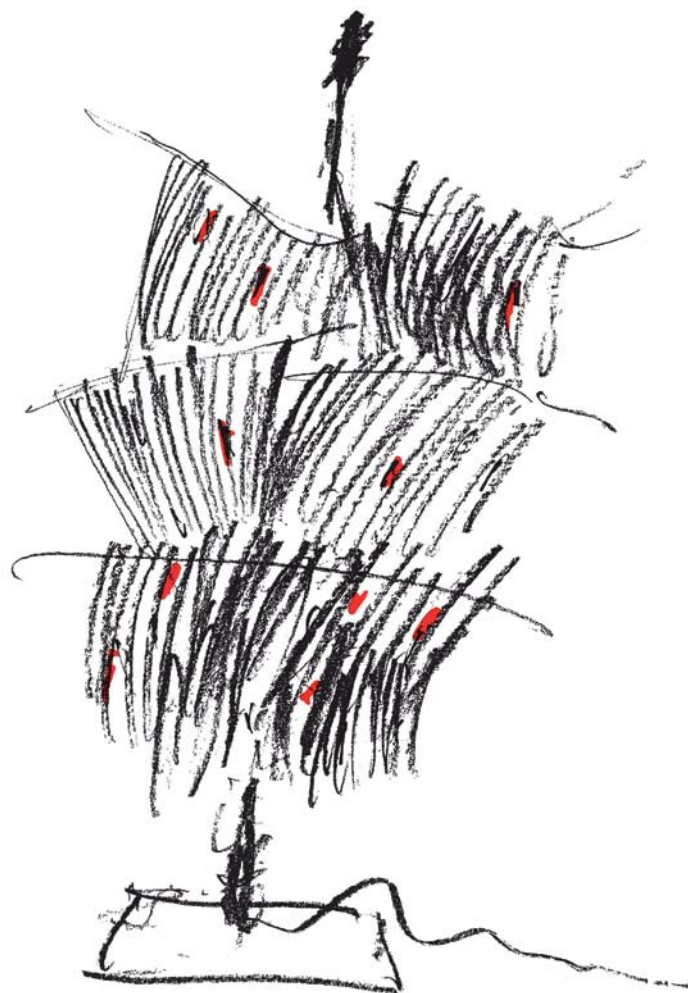


Gaku *Dagmar Mombach, Ingo Maurer und Team 1998*

Papier, Metall, Edelstahl, Silikon, Glas. Lieferung mit Leuchtmittel. ■ Paper, metal, stainless steel, silicone, glass. Complete with bulb. ■ Papier, métal, acier inoxydable, silicone, verre. Livrée avec ampoule. ■ Carta, metallo, acciaio inossidabile, silicone. Lampadina inclusa. ■ Papel, metal, acero fino, silicona, cristal. Suministrada con bombilla.



95



Die MaMo Nouchies sind nicht für Räume mit hoher Luftfeuchtigkeit geeignet. ■ The MaMo Nouchies are not suited for rooms with high humidity. ■ Les MaMo Nouchies ne sont pas appropriées pour des pièces avec un fort taux humidité. ■ I MaMo Nouchies non sono adatti all'uso in ambienti con alta umidità. ■ Las MaMo Nouchies no están recomendadas para espacios con un alto porcentaje de humedad.



The MaMo Nouchies exhibited at a museum in New York, 2007





LED + O

makes

OLED



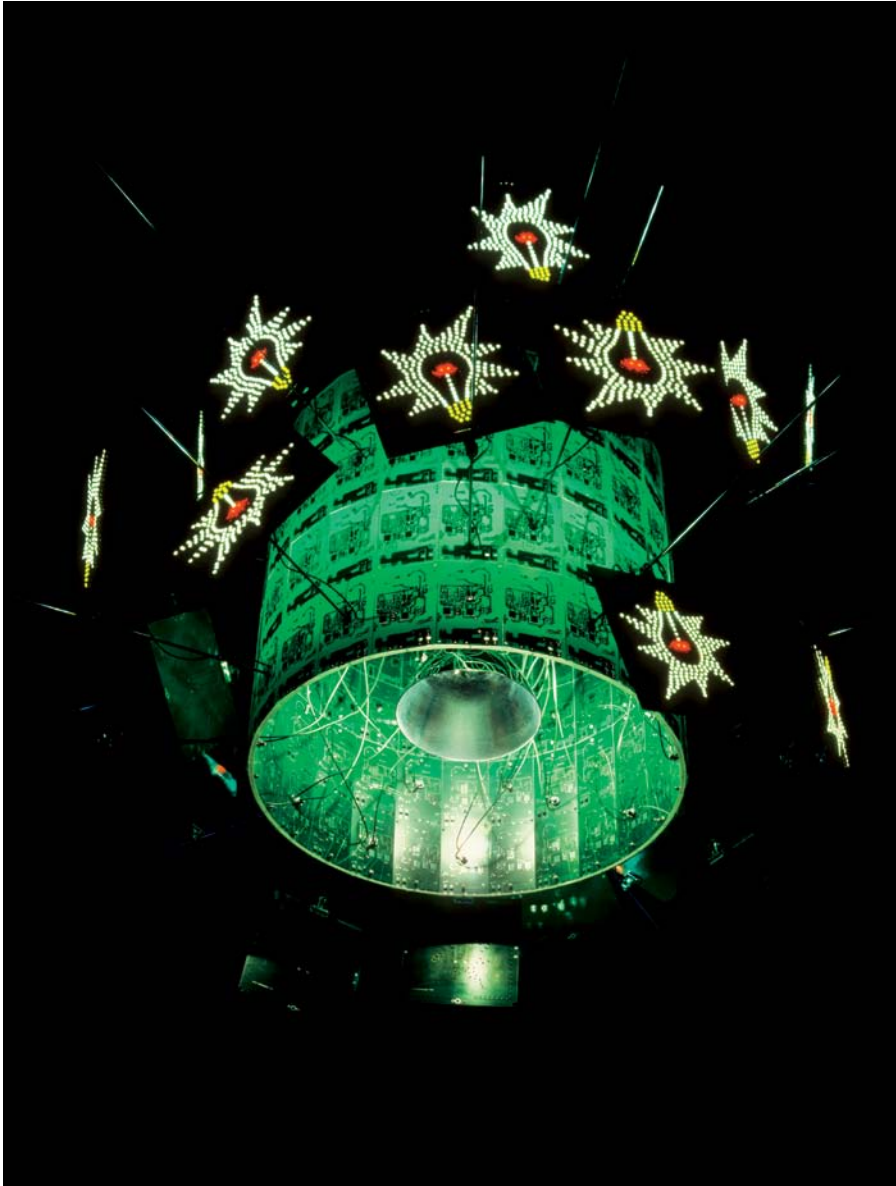
CIRCUIT
BOARD
GREEN
LED



Bellissima Brutta*

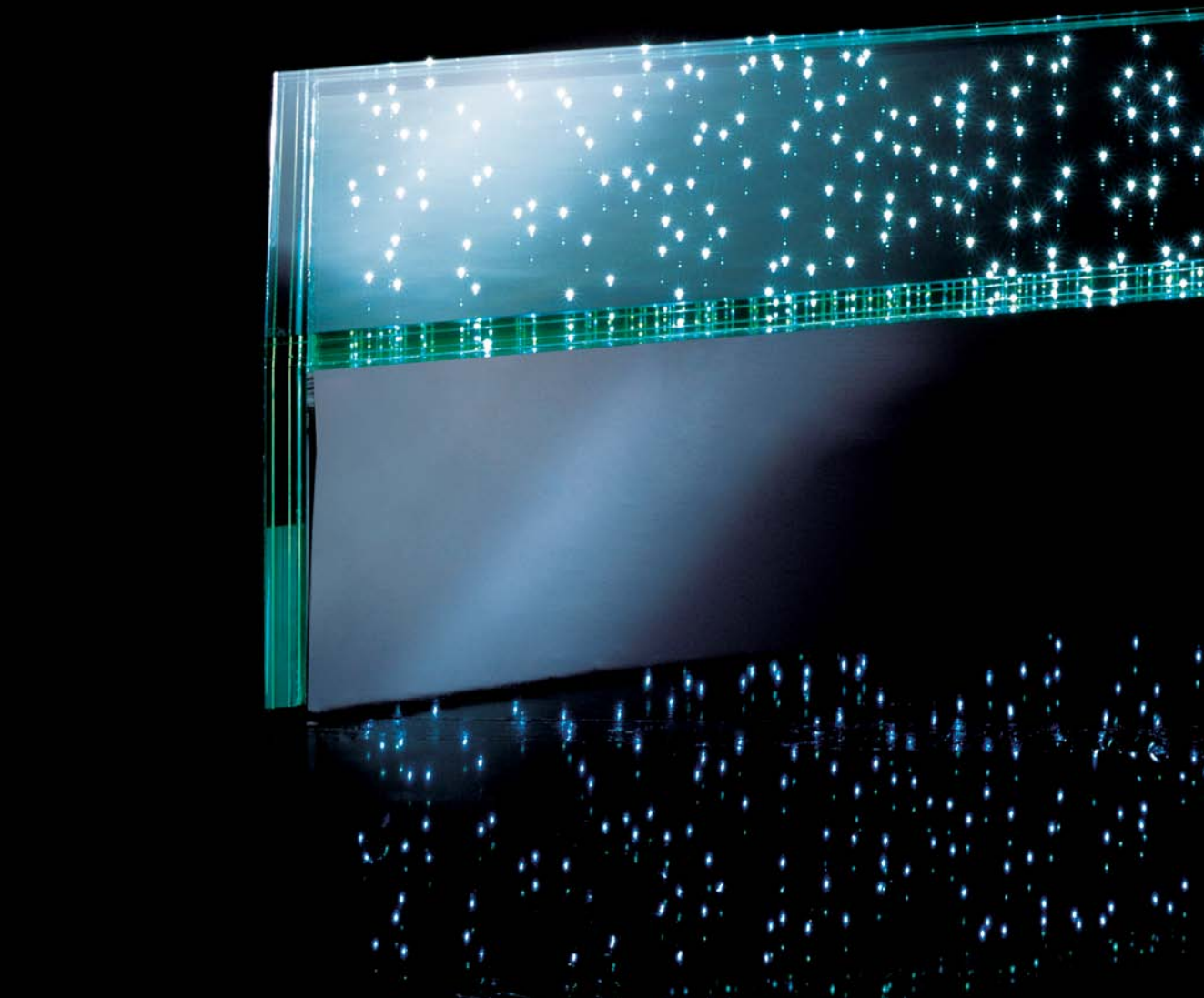


Stardust*



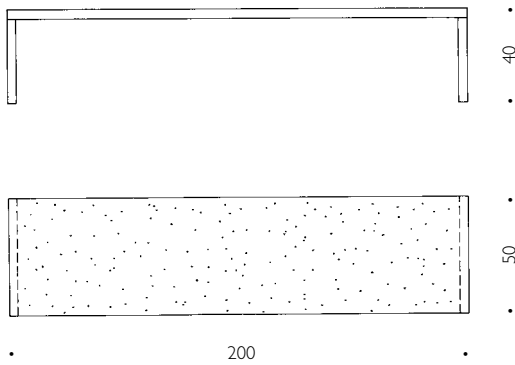
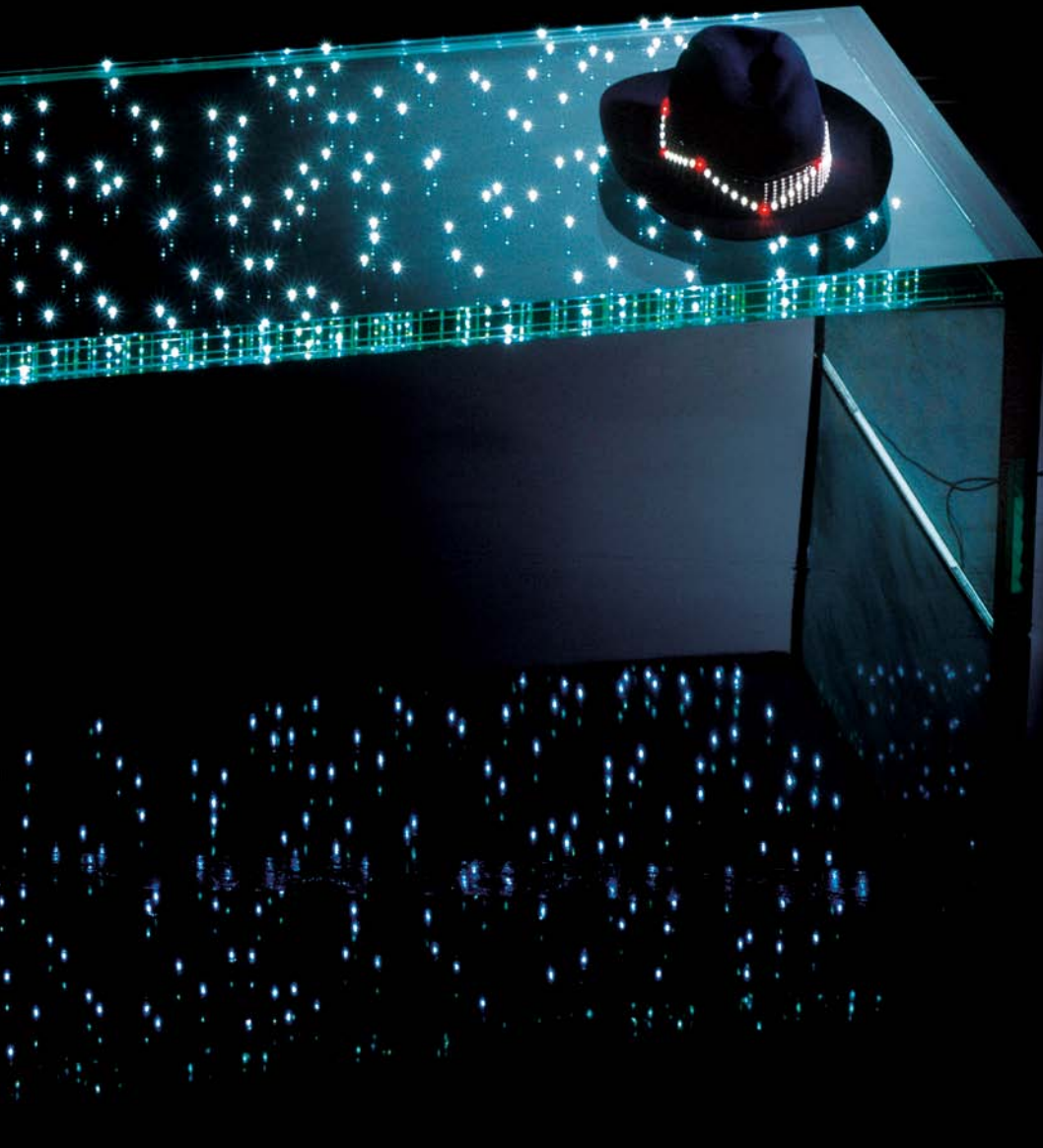
Licht.Enstein*

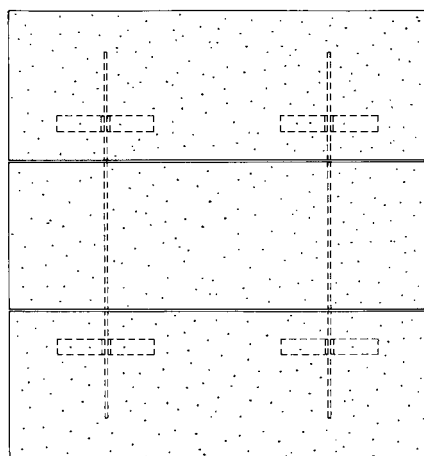
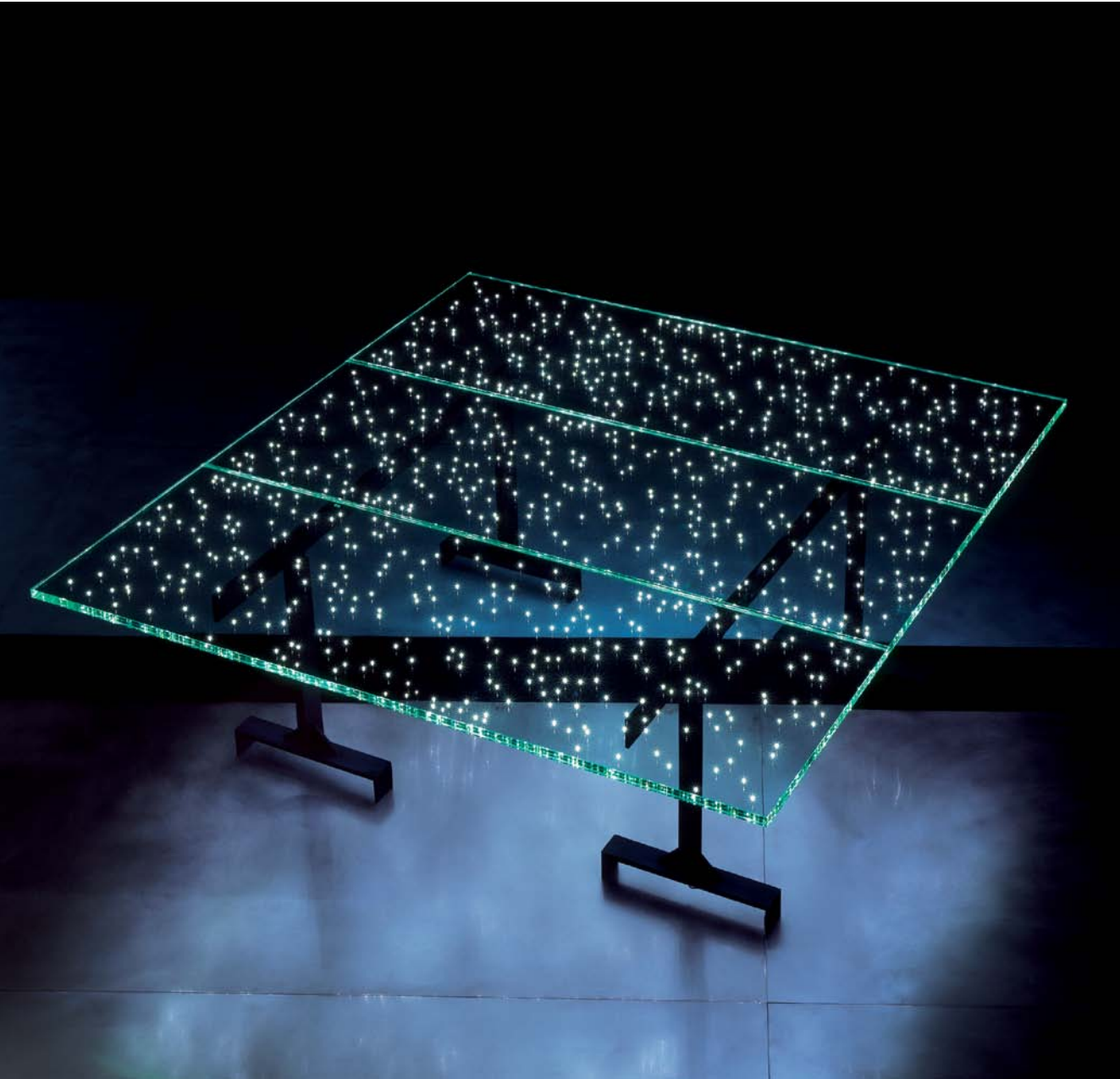
Thinking of Roy Licht.Enstein!



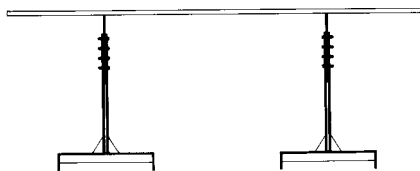
LED Bench Ingo Maurer 2002

Glas, 288 innen liegende weiÙe LEDs, beidseitig leuchtend. Dimmbar durch externes Vorschaltgerät. Die LEDs scheinen in der Glasfläche zu schweben, denn keine Leiterbahnen oder Kabel sind sichtbar. Ca. 135 kg. ■ Moulded glass. Within the glass, 288 white LEDs emit light on both sides. Possibility of dimming by use of an external ballast. The LEDs seem to be floating on the glass like magic. No conductors or cables are visible. Ca. 135 kg. ■ Verre. 288 LED blanches à émission lumineuse bilatérale à l'intérieur. Variation de l'intensité lumineuse par un ballast externe. Les LED semblent flotter sur la surface de verre, car ni câble, ni fil électrique ne sont visibles. Env. 135 kg. ■ Vetro. 288 LED bianchi a emissione luminosa bilaterale collocati all'interno. Intensità luminosa regolabile tramite un alimentatore a corrente continua esterno. Non essendo visibili conduttori d'alimentazione o cavi, i LED sembrano galleggiare all'interno del vetro. 135 kg ca. ■ Vidrio, 230/125 V. 288 LEDs blancas ubicadas en el interior iluminan a ambos lados. Regulación de intensidad a través de un balastro externo. Las LEDs parecen flotar en la superficie del cristal, dado que no quedan visibles líneas ni cables. Ca. 135 kg.





215



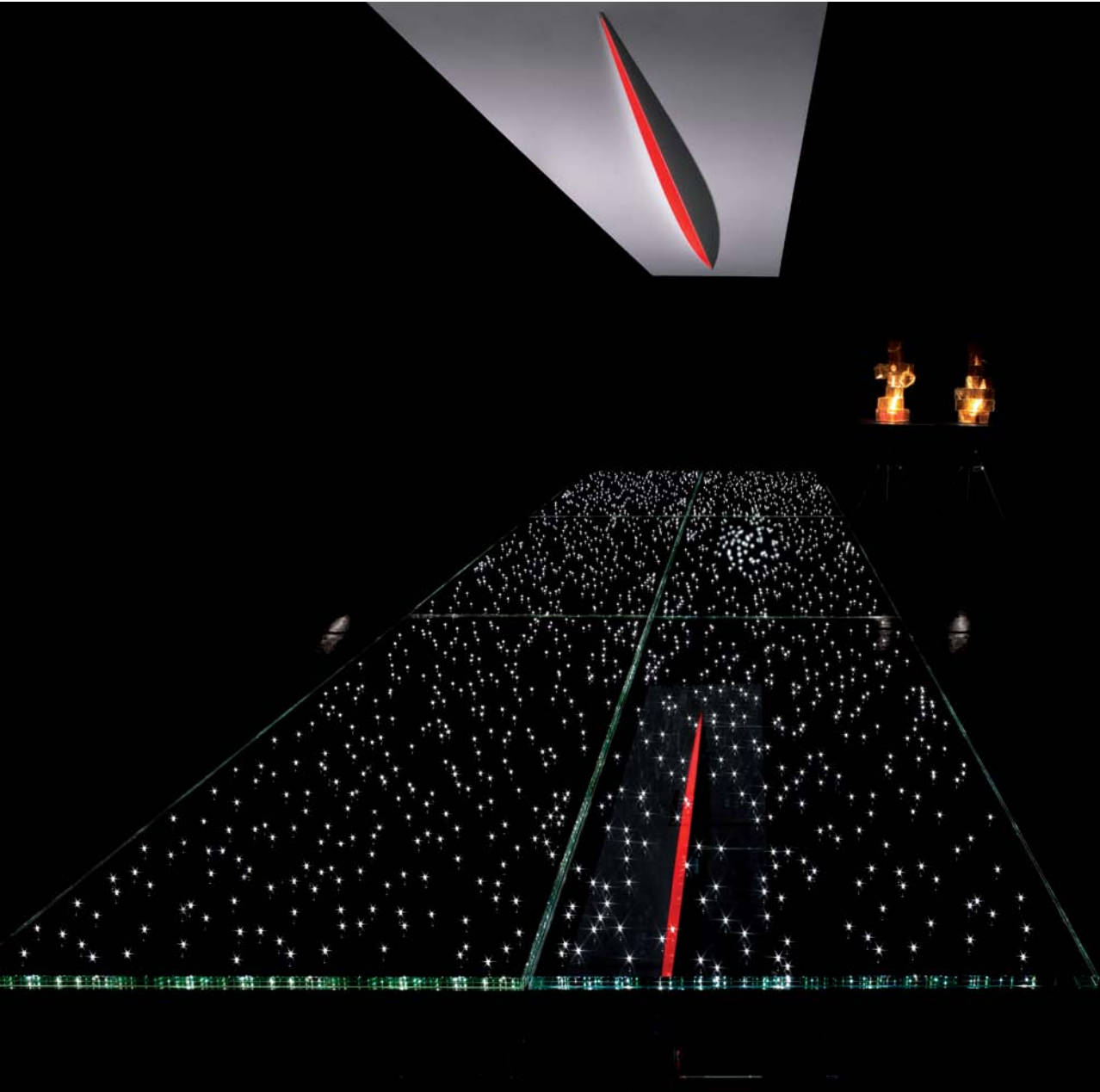
215

75

151

227

ca. 77-92

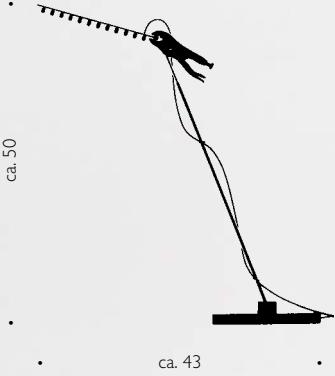
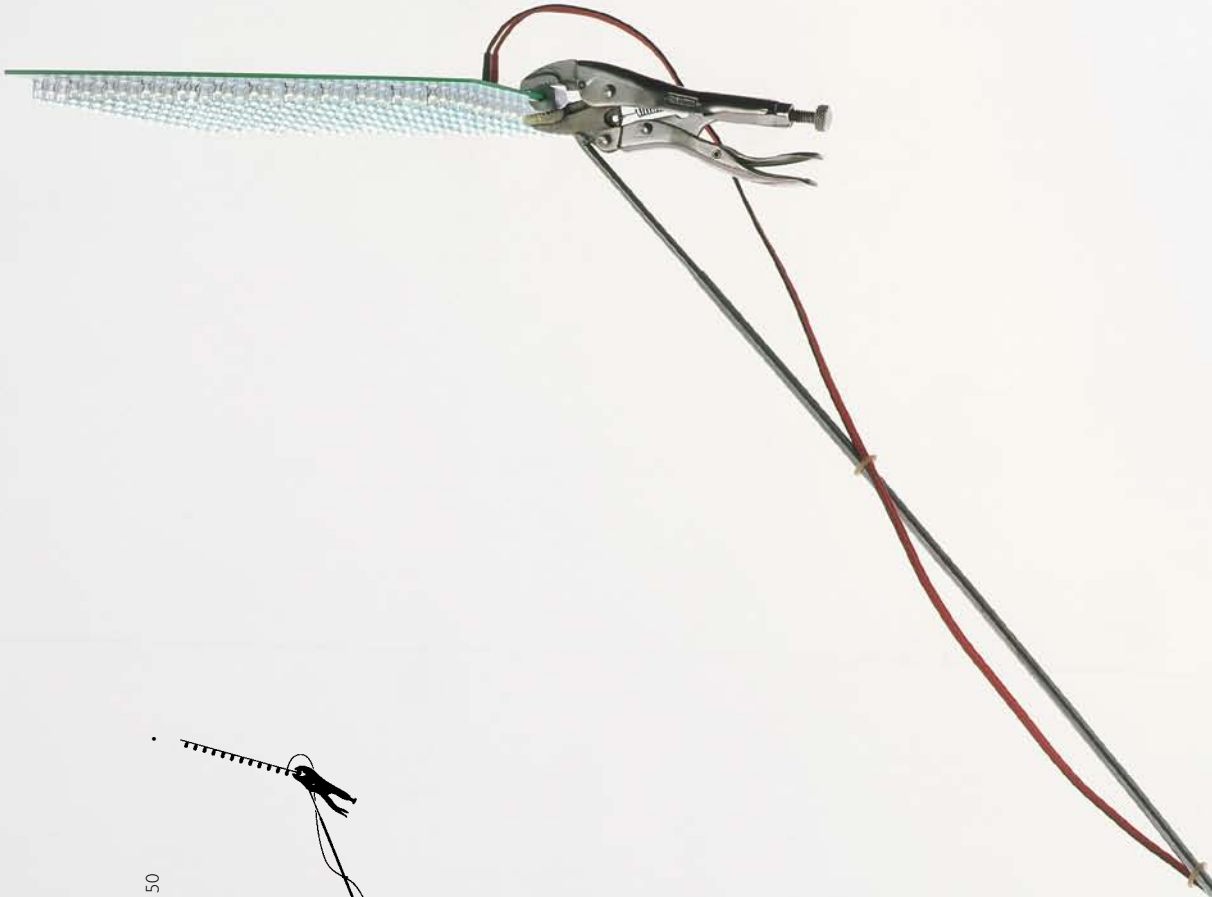


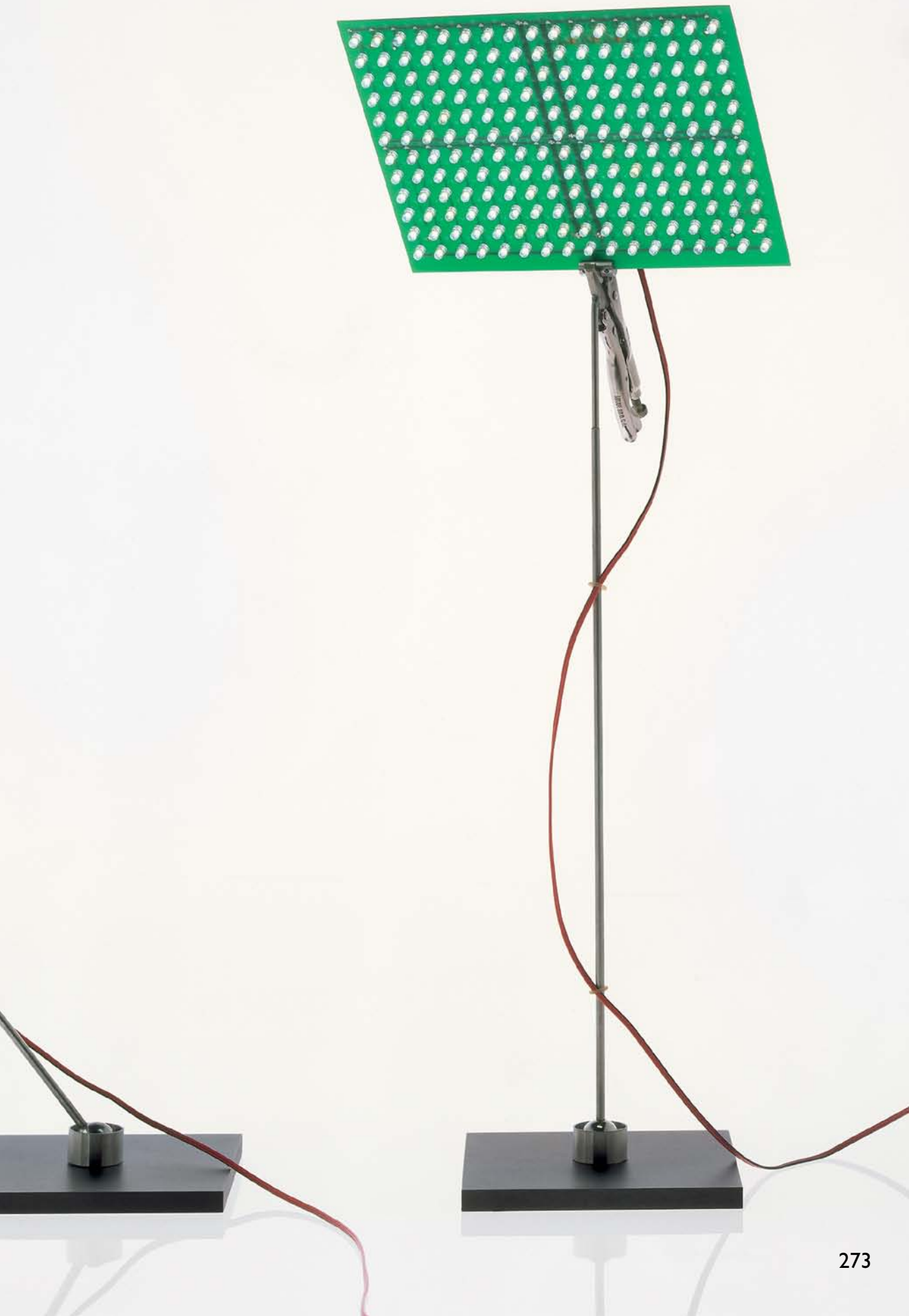
LED Table *Ingo Maurer 2003*

Sicherheitsglas. Metall. 278 innen liegende weiße LEDs pro Glasplatte, beidseitig leuchtend. Unsichtbare Stromführung. Dimmbar durch externes Vorschaltgerät. Höhenverstellbare Metallgestelle. Lieferbar mit 1, 2 oder 3 Glasplatten. Gewichte: mit 2 Glasplatten ca. 360 kg, mit 3 Glasplatten ca. 500 kg. ■ Laminated safety glass, metal. 278 white LEDs per table top inside, emitting light on both sides. Invisible live parts. Possibility of dimming by use of an external ballast. Metal bases adjustable in height. Available with 1, 2 or 3 table tops. Weights: with 2 table tops approx. 360 kg, with 3 table tops approx. 500 kg. ■ Verre feuilleté, métal. 278 LEDs blanches à émission lumineuse bilatérale à l'intérieur d'un plateau. Conduction invisible du courant. Variation de l'intensité lumineuse par un ballast externe. Supports métalliques réglables en hauteur. Livrable avec 1, 2 ou 3 plateaux en verre. Poids: avec 2 plateaux env. 360 kg, avec 3 plateaux env. 500 kg. ■ Vetro temperato, metallo, 278 LEDs bianchi a emissione luminosa bilaterale collocati all'interno di ogni lastra. Conduttori elettrici tra i LED invisibili. Intensità luminosa regolabile tramite un alimentatore a corrente continua esterno. Con piedi in metallo regolabili in altezza. Disponibile con 1, 2 o 3 lastre. Pesi complessivi: con 2 lastre ca. 360 kg., con tre lastre ca. 500 kg. ■ Cristal de seguridad, metal. 278 LEDs blancas por placa de cristal, ubicadas en el interior, iluminan a ambos lados. Línea de corriente invisible. Regulación de intensidad a través de un balastro externo. Armazón de metal de altura ajustable. Suministrada con 1, 2 ó 3 placas de cristal. Peso: con 2 placas de cristal aprox. 360 kg, con 3 placas de cristal aprox. 500 kg.

EL.E.DEE Ingo Maurer 2001

EL.E.Dee, our first LED task lamp, is sold out. An avantgarde design of 2001, now a collector's item.

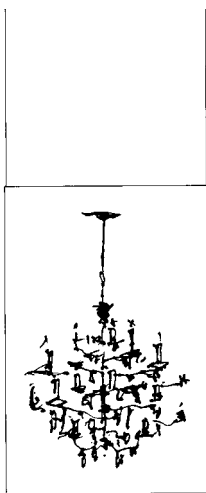




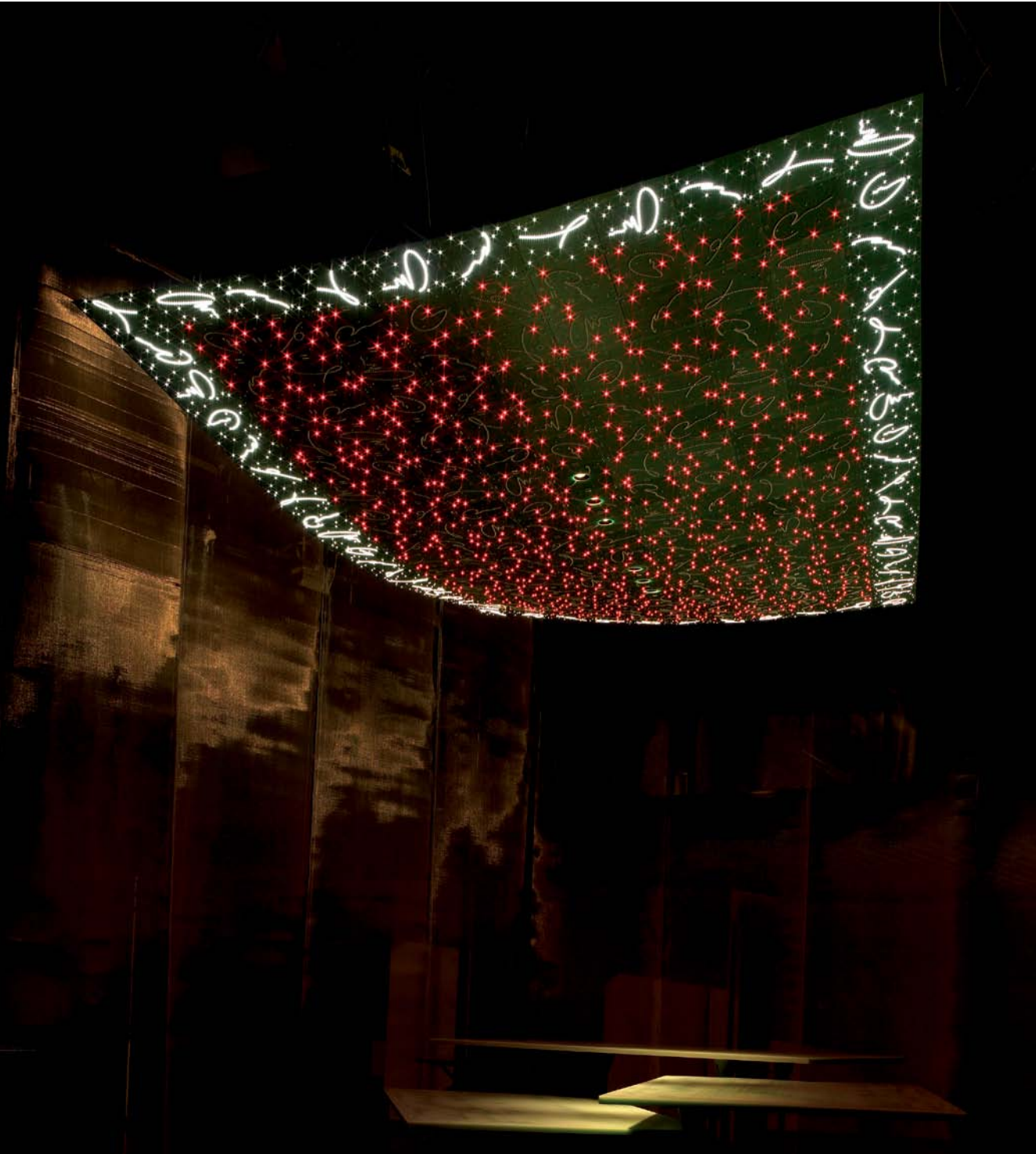


Lüster Ingo Maurer 2003

Bedrucktes Glas. 287 innen liegende weiße LEDs, beidseitig leuchtend. Dimmbar durch externes Vorschaltgerät. Keine Leiterbahnen oder Kabel sind sichtbar, die Abhängeseile versorgen den Lüster mit Strom. ■ Imprinted moulded glass. Within the glass, 287 white LEDs emit light on both sides. Possibility of dimming by use of an external ballast. No conductors or cables are visible. The suspension wires transport electricity to the chandelier. ■ Verre imprimé. 287 LED blanches à émission lumineuse bilatérale. Variation de l'intensité lumineuse par un ballast externe. Aucun fil et câble électrique ne sont visibles, les fils de suspension alimentent le lustre en courant. ■ Vetro stampato. 287 LED bianchi a emissione luminosa bilaterale collocati all'interno. Intensità luminosa regolabile tramite un alimentatore a corrente continua esterno. Non sono visibili conduttori d'alimentazione o cavi; il lampadario è alimentato da cavi di sospensione. ■ Cristal tallado. En su interior se encuentran 287 LED blancos que iluminan ambos lados. Regulación de intensidad a través de un balastro externo. Los cables y los conductores de conexiones invisibles. Los cables de los que cuelga la lámpara son suministradores de energía.



230/125/48 Volt DC, ca. 25 W



* Limited production, Gestaltung: Ingo Maurer 2006



One Thousand and One Lights*



* Limited production, Gestaltung: Ingo Maurer 2007



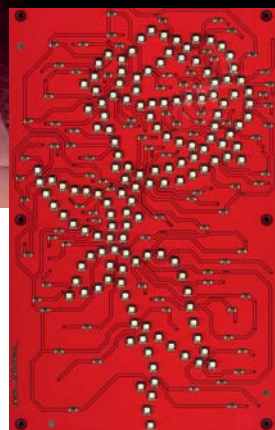
LED Paravent*



1001 Lights, LED Paravent, and Rose Rose on the Wall are majestic objects custom-made from circuit boards with LEDs. They are a seduction to dream on and let yourself be taken to another uncharted world. Colour and radiance can be adjusted to suit your mood.



Rose, Rose on the Wall ...*



* Limited production, Gestaltung: Ingo Maurer 2006

LED Wallpaper





LED and imagination come together
in the first wallpaper you can switch on and off
to illuminate a room, dim it, or change
the pattern and colours to suit any mood.



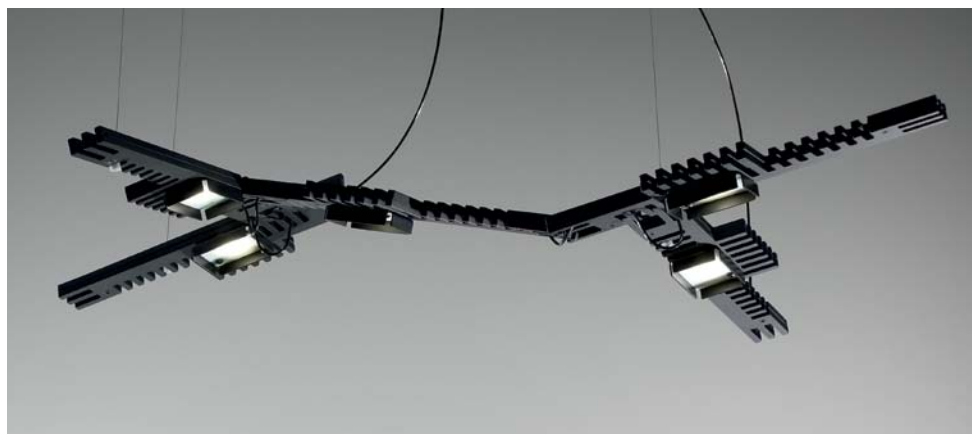
Lunatic

New technologies open up paths to new forms, giving shape to what was at one time pure imagination. In April 1997, I introduced our first LED table lamp, *Bellissima Brutta*, followed by many “one of a kind” objects, and the first LED task lamp *EL.E.De*, in 2001, now sold out and a collector’s item.

LED is still on the leading-edge and a technology that has become an influential part of our lighting toolbox: *Zufall Table*, *Jetzt*, *Looksoflat*, *Radarr*, *WoonderLux*, *Lunatic* and *Manifold* all use LEDs. What was once a dream of the future is now reality, and can be found throughout the collection we produce today.

In 2006 OLED arrives on the scene. Again, we were pioneers decoding a new technology, and created *Flying Future*, OLED coffee table, and the first limited production table lamp, *Early Future*. Later in 2008 with custom-made OLED modules by *Merck* and *Osram* we designed *Double C. Future* and *Double T. Future*. They were presented in 2010 alongside a new version of *Flying Future*. The new version of *Flying Future* and also *4 x 4 is 34* are made with future-forward transparent OLEDs by *Noval*.

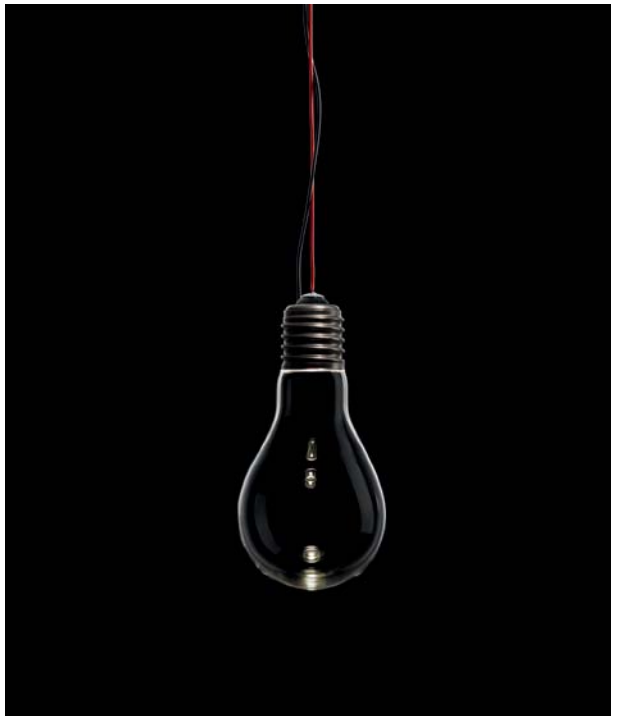
I.M.



Manifold



Zufall



WoonderLux



Radarr



Looksoflat



Jetzt



Early Future Ingo Maurer 2008

Limitierte Auflage. Metall, Glas, 10 OLED Module von OSRAM Opto Semiconductors. Externes elektronisches Vorschaltgerät. ■ Limited edition. Metal, glass, 10 OLED modules by OSRAM Opto Semiconductors. External electronic ballast. ■ Édition limitée. Métal, verre, 10 modules OLED de OSRAM Opto Semiconductors. ■ Edizione limitata. Metallo, vetro, 10 moduli OLED di OSRAM Opto Semiconductors. Con alimentatore a corrente continua esterno. ■ Edición limitada. Metal, vidrio, 10 módulos OLED de OSRAM Opto Semiconductors. Balastro electrónico externo.



One Off, 2006

Flying Future





Double C. Future* Ingo Maurer 2010

A combination of OLED modules and LEDs, wired for separate switching. The LED spots can be adjusted flexibly via cardan joints. Suspension on four live wires.



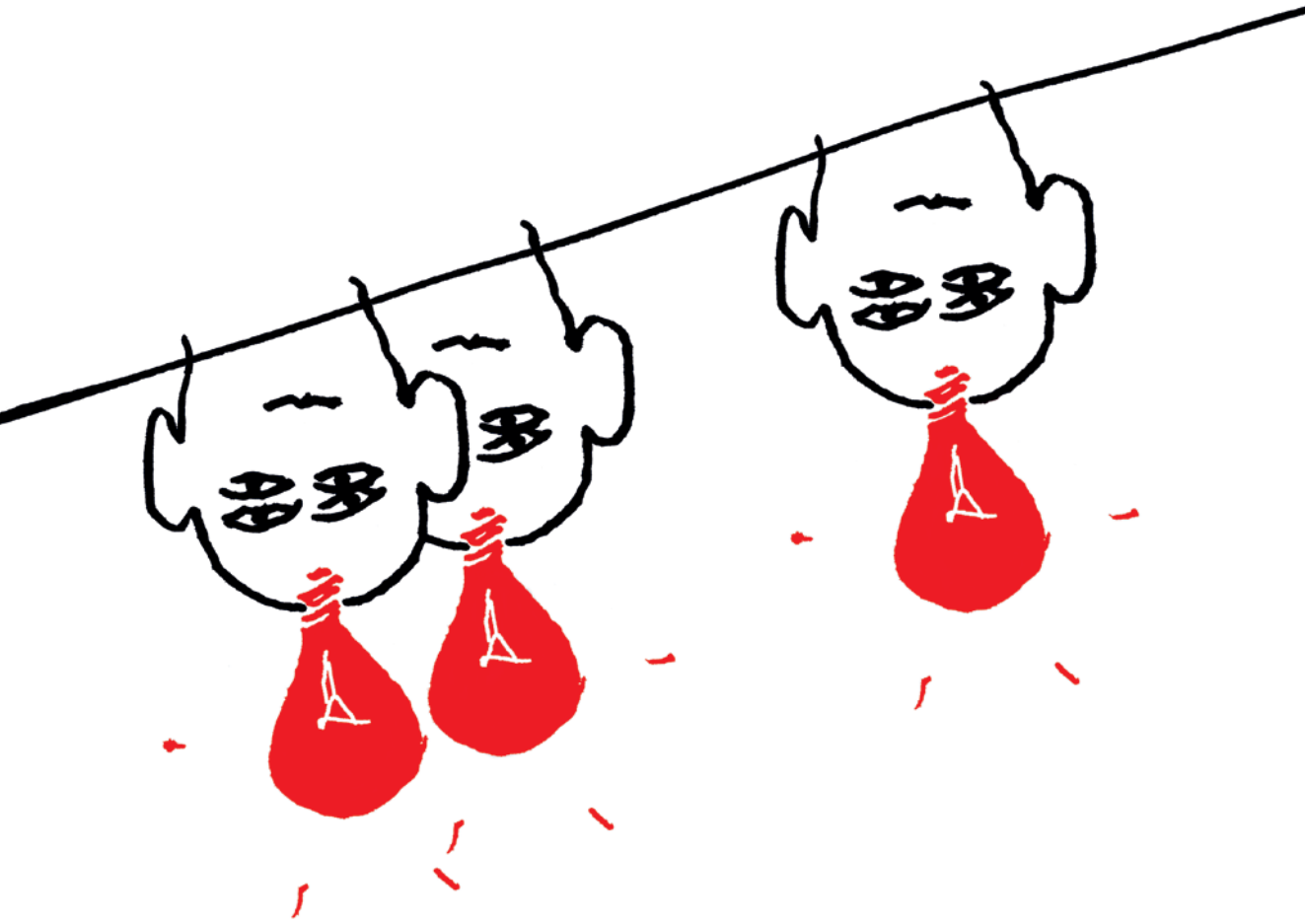
Double T. Future* *Ingo Maurer 2010*

OLED and LED spots, wired for separate switching, as in the suspension version.
The angle of the lamp head is freely adjustable via ball-joint.



4 x 4 is 34 *Ingo Maurer 2010*

Four transparent OLED modules on glass plates. 4 x 4 is 34 is a One-Off experimental object.



Yá Yá Ho

Die Idee für YaYaHo (1984) kam wie ein Blitz aus heiterem Himmel: Am frühen Neujahrmorgen des Jahres 1980 sah Ingo Maurer auf Haiti Glühlampen, die direkt mit den Stromkabeln verlötet waren und die Straßen für das Fest beleuchteten. Nach vier Jahren harter Entwicklungsarbeit war das System aus Niedervolt-Halogenreflektoren, die von straff gespannten Kabeln abgehängt werden, perfektioniert – ein Kraftaufwand, der seine Firma beinahe in den Bankrott geführt hätte. Gleichzeitig entwickelte ein Schweizer Designer, Hannes Wettstein, ein ähnliches Konzept, das ebenso wie YaYaHo häufig kopiert wurde.

Aber allen Plagiaten fehlt die Präzision und die detaillierte Ausarbeitung des aus 276 Teilen bestehenden Systems. YaYaHo ermöglicht seinen Anwendern, Höhe und Platzierung jedes Elements zu variieren und die Reflektionen mit kleinen, beweglichen Spiegeln anzupassen. „Ich möchte, dass meine Entwürfe etwas Unfertiges an sich haben, um den Menschen, die sie benutzen, Raum für ihren eigenen gestalterischen Beitrag zu lassen.“ Der Designkritiker Deyan Sudjic fand, dass YaYaHo mit seinem schillernden Funkeln, das an das Geflacker von Kerzen erinnert, „einen subversiven Angriff auf die oberflächliche mechanische Perfektion darstellt, die für die so genannten modernen Leuchten charakteristisch ist“.

The idea for YaYaHo (1984) came in a flash, following a New Year's celebration in Haiti, where Maurer saw how locals solder lightbulbs onto overhead power cords to illuminate street fairs. It took four years to perfect the system of suspending halogen reflectors from tautly strung low-voltage cables, and the effort almost bankrupted his company. Contemporaneous to his research, another designer, Hannes Wettstein, developed a similar concept and both were widely plagiarized.

However, the rip-offs lack the precision and artistry of the 276-part system. YaYaHo allows the user to adjust the height and placement of each suspended element as well as the tiny mirrors that bounce the light. "I want things to look unfinished, and to leave space for the people who use or look at them to add something of themselves," says Maurer. Critic Deyan Sudjic thought that YaYaHo "subverts the glossy mechanical perfection that characterizes so-called modern lighting," providing a sparkle and dazzle that take one back to the flutter of candlelight.

Michael Webb, 2003



Ya Ya Ho Ingo Maurer und Team 1984

Ya Ya Ho ist ein Niedervolt-Lichtsystem und wird über einen Transformator (Leistung max. 200 Watt) betrieben, der 230/125 Volt auf 12 Volt reduziert. Alle Elemente sind horizontal und einige zusätzlich auch vertikal beweglich. Lieferung mit Leuchtmittel, Bohrschablone und Spannwerkzeug. Jedes Part und jedes Element ist auch einzeln lieferbar. Montagehöhe: 230–250 cm. Belastbarkeit der Seile 350 Watt. Spannlänge ohne Deckenabhängung: 10 Meter. Sonderanfertigung und Planung auf Anfrage möglich. **Ya Ya Ho** is a low-voltage lighting system fed by a transformer (max. capacity 200 watts) which reduces the 230/125 volt mains current to 12 volts. All elements are adjustable – horizontally, and in some cases vertically, too. Complete with bulbs, cable tightener and drilling template. All parts and elements can also be ordered separately. Installation height 230–250 cm. Maximum capacity of cables: 350 watts. Maximum cable length without additional ceiling fixture: 10 m. We can also supply custom-designed systems – please ask for details. **Ya Ya Ho** est un système d'éclairage basse tension, relié à un transformateur (capacité maximum 200 watts) qui change les 230/125 volts en 12 volts. Tous les éléments sont mobiles horizontalement et quelque-uns en plus verticalement. Livré avec ampoule, gabarit de perçage et outils tendeurs. Chaque part et élément est également disponible individuellement. Hauteur de montage d'un système: 230 à 250 cm. Capacité maximum des câbles 350 watts. Longueur maximum des câbles sans utilisation



First photograph of YaYaHo, 1984

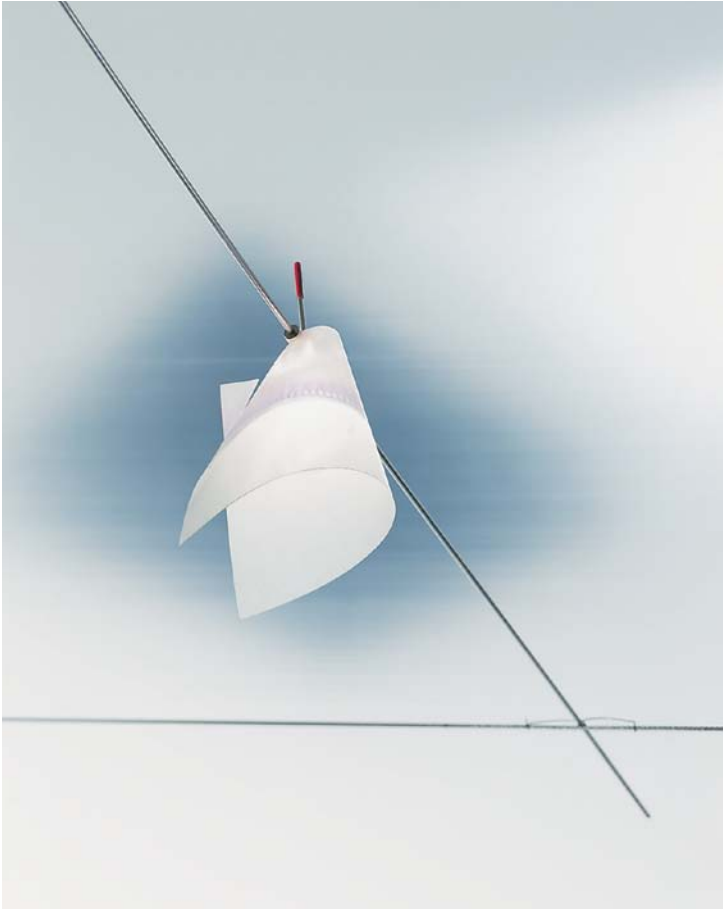
d'une suspension plafond: 10 mètres. Planification et modèles hors série peuvent être réalisés sur demande. **YaYa Ho** è un sistema di luci a basso voltaggio, alimentato da un trasformatore (potenza 200 watt max.) che riduce 230/125 volt a 12 volt. Tutti gli elementi sono regolabili in orizzontale e alcuni anche in verticale. Forniti con lampadina, dima di foratura e utensili per il montaggio. Ogni part e ogni elemento sono disponibili anche singolarmente. Altezza di montaggio di un sistema: da cm. 230 a cm. 250. Carico massimo dei cavi 350 watt. Lunghezza massima dei cavi senza dispositivo di fissaggio al soffitto: 10 metri. Realizzazioni speciali e progettazione su richiesta. **Ya Ya Ho** es un sistema de luces de bajo voltaje que funciona mediante un transformador (potencia máx. 200 vatios) que reduce de 230/125 voltios a 12 voltios. Los elementos son desplazables en horizontal y algunos también en vertical. Suministrada con bombilla, plantilla de taladrado y herramienta de sujeción. Cada pieza y elemento también está disponible por separado. Altura de montaje: 230–250 cm. Carga de los cables: 350 vatios. Longitud sujetable sin colgar del techo: 10 metros. Fabricaciones especiales y planificación posible a petición.



New element No. 14 for YaYa Ho in silicone.



The groundbreaking low-voltage system from 1984, welcomes a new addition to the family – the Element 14.



Element 6



Element 3



Element I



Element 77



Element 4 + 5

Y&Y Ho Element 4, Element 5

Auf den Seilen horizontal und vertikal beweglich. ■ Adjustable vertically and horizontally along the wires. ■ Mobile à l'horizontale et à la verticale sur les câbles métalliques. ■ Mobile lungo i cavi in orizzontale e verticale. ■ Desplazable por cables horizontales y verticales.

Element 6, Element 3

Multi Mirror-Reflektor. Auf den Seilen horizontal beweglich, Leuchtenkopf schwenkbar. ■ Multi-Mirror reflector. Adjustable horizontally along the wires, reflector unit swivels. ■ Réflecteur Multi Mirror. Mobile à l'horizontale sur les câbles métalliques. La tête du luminaire est pivotante/rotative. ■ Riflettore Multi Mirror. Elemento mobile lungo i cavi in orizzontale e verticale. Corpo illuminante rotante e basculante. ■ Reflector Multi Mirror. Este elemento es desplazable por cables horizontales y verticales. El cabezal de la lámpara es virable.

Element 1

Auf den Seilen horizontal beweglich. ■ Adjustable horizontally along the wires. ■ Mobile à l'horizontale sur les câbles métalliques. ■ Elemento mobile lungo i cavi in orizzontale. ■ Desplazable por cables horizontales y verticales.





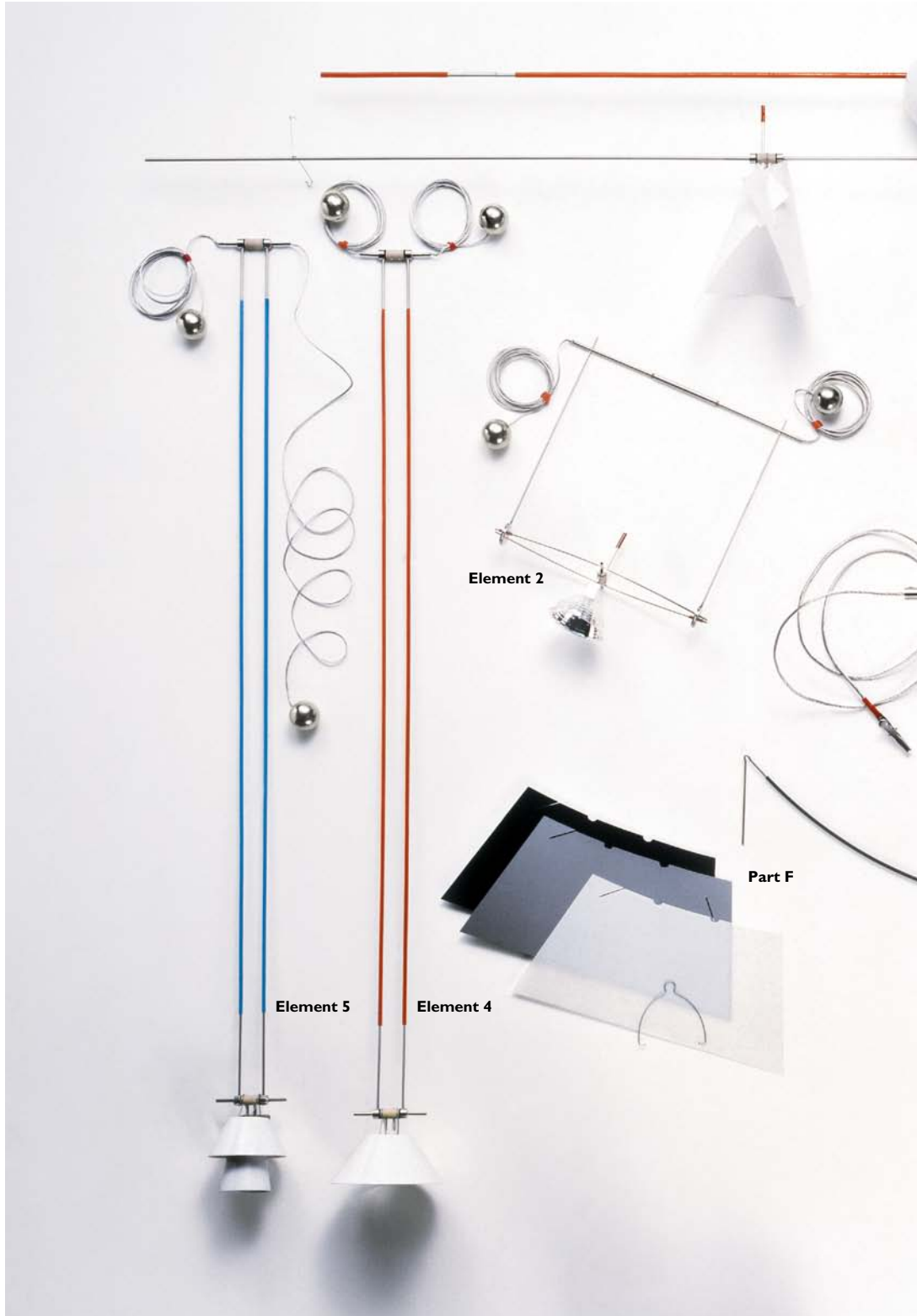
Element 2 + Mirror

Element 2 + Spiegel / Mirror / Miroir / Specchio / Espejo

Multi Mirror-Reflektor. Auf den Seilen horizontal und vertikal beweglich. Leuchtenkopf schwenkbar. Lieferbar auch ohne Spiegel. ■ Multi-Mirror reflector. Adjustable vertically and horizontally along the wires. Reflector unit swivels. Also available without mirror. ■ Réflecteur Multi Mirror. Mobile à l'horizontale et à la verticale sur les câbles métalliques. La tête du luminaire est pivotante/rotative. Egalement disponible sans miroir. ■ Riflettore Multi Mirror. Mobile lungo i cavi in orizzontale e verticale. Corpo illuminante rotante e basculante. Disponibile anche senza specchio. ■ Reflector Multi Mirror. Desplazable por cables horizontales y verticales. El cabezal de la lámpara es virable. También se suministra sin espejo.

Element 77

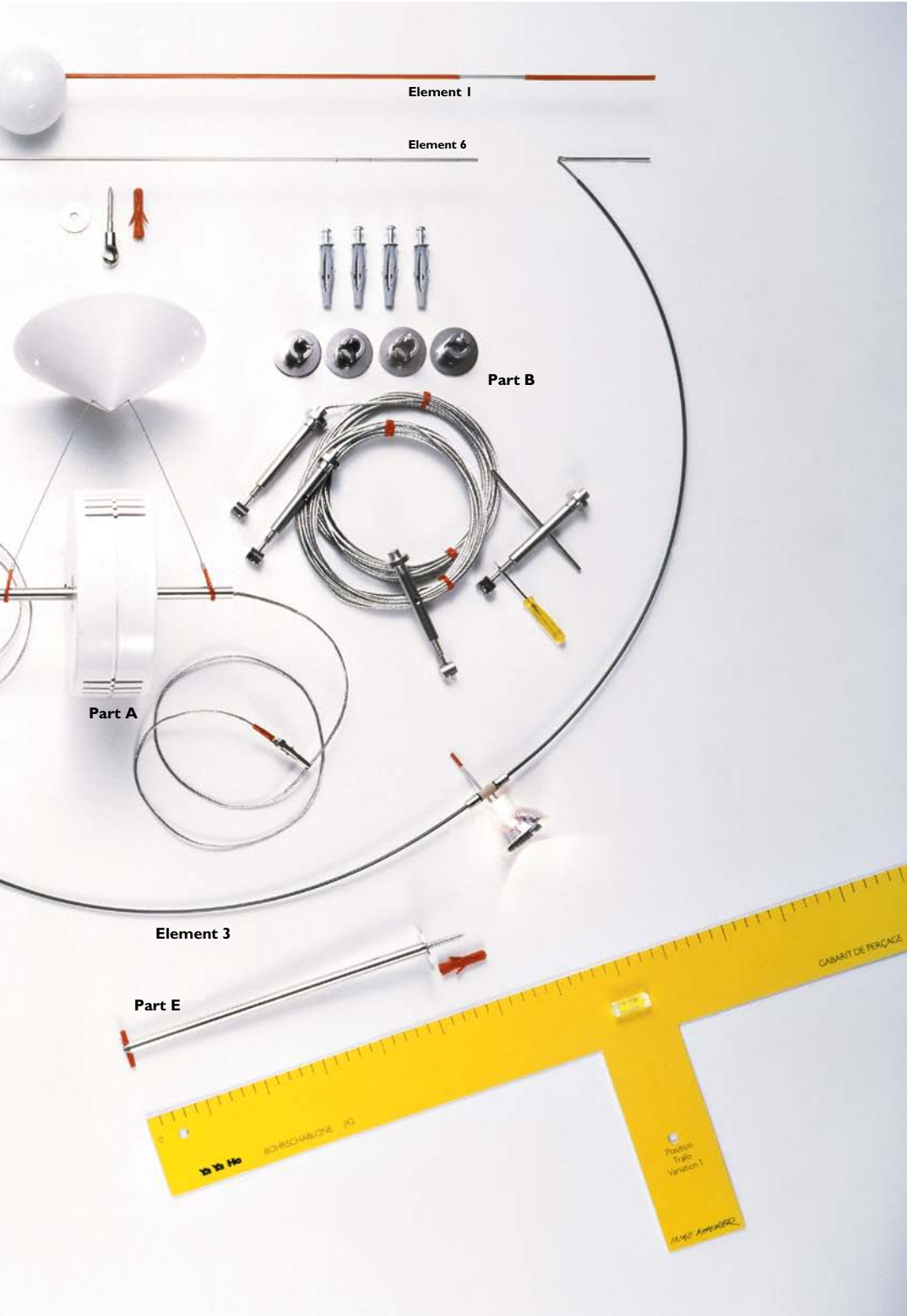
Multi Mirror-Reflektor. Auf den Seilen horizontal und vertikal beweglich. Leuchtenkopf schwenkbar. ■ Multi-Mirror reflector. Adjustable vertically and horizontally along the wires. Reflector unit swivels. ■ Réflecteur Multi Mirror. Mobile à l'horizontale et à la verticale sur les câbles métalliques. La tête du luminaire est pivotante/rotative. ■ Riflettore Multi Mirror. Mobile lungo i cavi in orizzontale e verticale. Corpo illuminante basculante. ■ Reflector Multi Mirror. Desplazable por cables horizontales y verticales. El cabezal de la lámpara es virable.



Ya Ya Ho besteht aus **Parts** und **Elementen**, die einzeln verfügbar sind. Für individuelle Zusammenstellung. Wichtig zu beachten: Gebrauchsanweisung und Gesamtwattzahl.

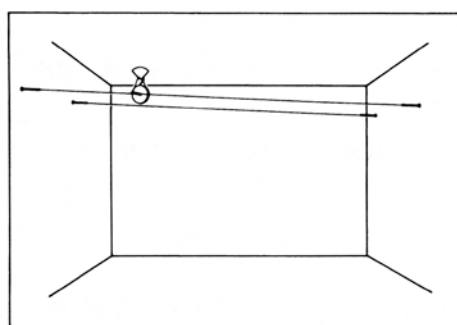
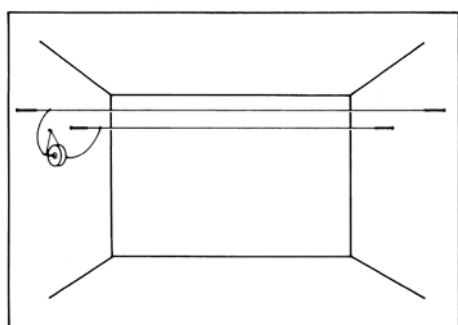
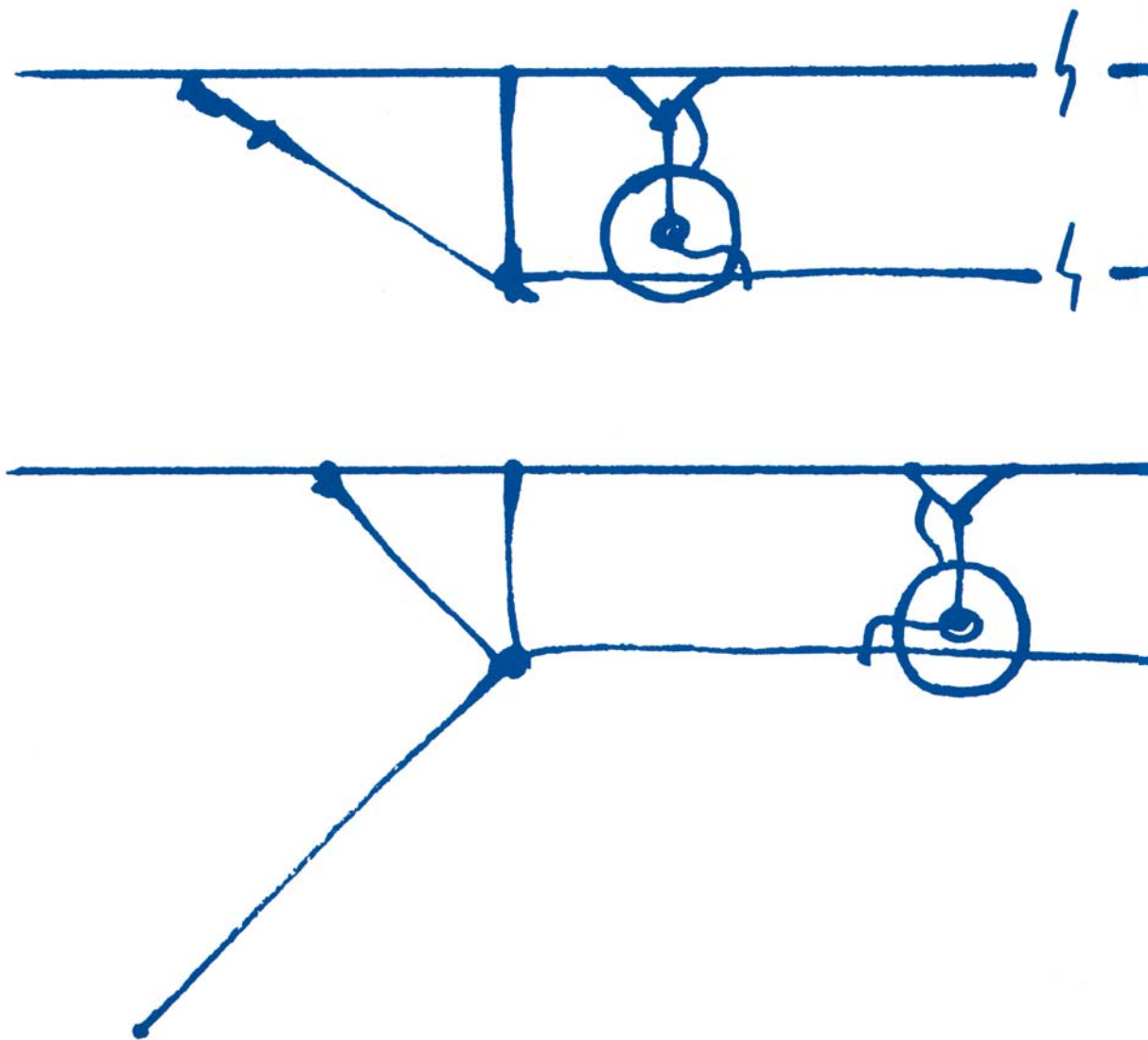
Ya Ya Ho is composed of **Parts** and lighting **Elements**, which are separately available. For unique configurations. Important: Study mounting instructions and observe total wattage.

Ya Ya Ho est composé de **Parts** et d'**Eléments**, qui sont disponibles séparément. Pour compositions individuelles. Important: observer attentivement les instructions de montage et le nombre total de watts.



Ya Ya Ho consiste in **Parti** ed **Elementi**, disponibili separatamente. Per soluzioni individuali. Importante: Seguire esattamente le istruzioni di montaggio e osservare la potenza massima consentita.

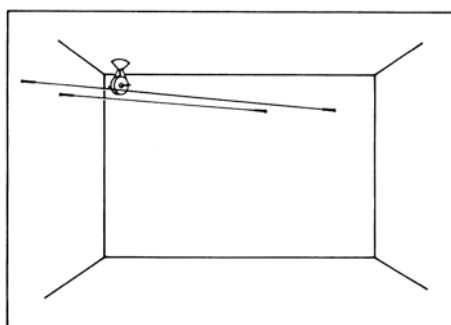
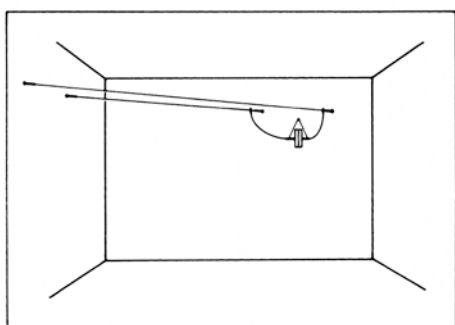
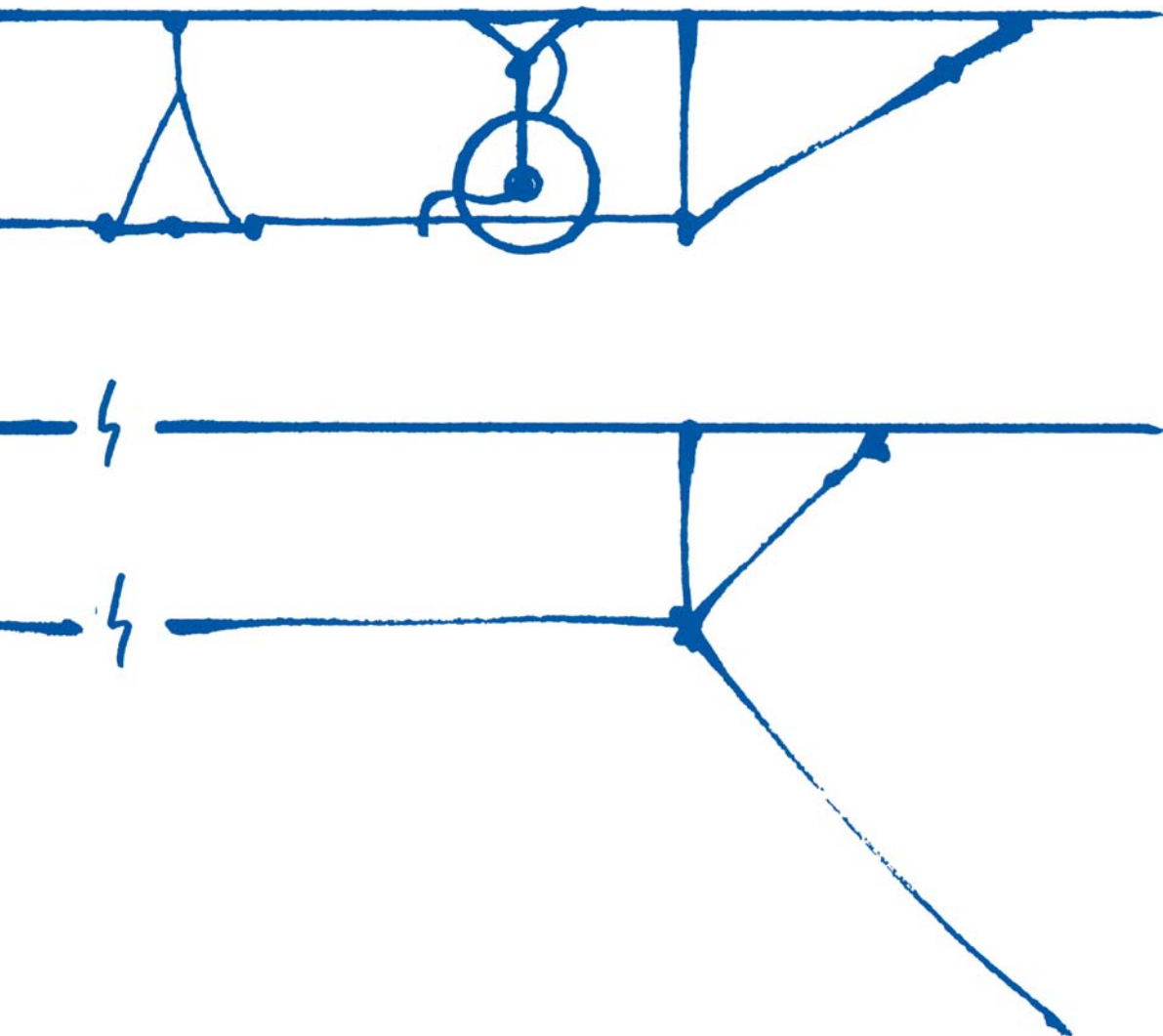
Ya Ya Ho está compuesta por **Piezas** y **Elementos** disponibles por separado. Para composiciones individuales. A tener en cuenta las instrucciones de uso y los vatios totales.



Ya Ya Ho lässt sich von der Decke und auch über Eck abspannen. Durch Verwendung von Isolierteilen können Sie die Länge des Systems erweitern, und mit einem zweiten Transformator kann die Anzahl der Lichtelemente erhöht werden.

Ya Ya Ho can also be installed on ceilings or in corners. Insulators can also be used to extend the length of the system, and a second transformer may be added to increase the number of lighting elements.

Ya Ya Ho se fixe au plafond et également en coin. L'emploi des parties isolatrices permet d'augmenter la longueur du système et un deuxième transformateur d'augmenter le nombre des éléments lumineux.



Ya Ya Ho può essere installato a soffitto oppure ad angolo. Utilizzando isolatori è possibile aumentare la lunghezza del sistema, e un secondo trasformatore consente di ampliare la quantità di elementi illuminanti.

Ya Ya Ho puede colgarse del techo y también en una esquina. Mediante el uso de piezas aislantes puede ampliarse la longitud del sistema. Con un segundo transformador puede aumentarse el número de elementos luminosos.



Yá Yá Ho Ingo Maurer und Team 1984

Part A: Transformator weiß mit 230/125-Volt-Zuleitung mit Schalter; für Wand- und Deckenmontage. **Part B:** 2 Spezialseile à 6, 8 oder 10 Meter, 4 Wandbefestigungen mit isolierten Spannschlössern, geeignet zur Montage auch auf leitenden Materialien. **Part D:** 2 x 2 Spezialseile à 6, 8 oder 10 Meter, 4 Wandbefestigungen mit isolierten Spannschlössern sowie zwei Isoliereinheiten und Deckenabhängung; für beide Teillängen wird je ein Transformator benötigt. **Part E:** Metallstäbe mit 25,5 cm Länge für Deckenabspannung oder Über-Eck-Spannung der Spezialseile. **Part F:** Blenden für Lichtelemente 2, 3 und 6. Naturfarben, Schwarz.

Part A: Transformer white, with 230/125-volts lead and switch, for wall or ceiling installation. **Part B:** 2 special cables (length 6, 8 or 10 m), 4 wall anchors with insulated tensioning bolts, attachable to any kind of surface including conductive materials. **Part D:** 2 pairs of special cables (length 6, 8 or 10 m), 4 wall anchors with insulated tensioning bolts, 2 insulators, ceiling fixture; separate transformer required for each pair of cables. **Part E:** Nickel-plated metal rods, length 25,5 cm, for ceiling or corner installation. **Part F:** Shades for lighting elements 2, 3 and 6. Colours: natural, black.

Part A: transformateur blanc avec câble d'alimentation 230/125 volts et interrupteur pour le montage au mur ou au plafond. **Part B:** 2 câbles spéciaux d'une longueur de 6, 8 ou 10 m, 4 fixations murales avec tendeurs isolés permettant également un montage sur matériaux conducteurs. **Part D:** 2 x 2 câbles spéciaux d'une longueur de 6, 8 ou 10 m, 4 fixations murales avec tendeurs isolés et également deux unités d'isolation et suspension plafond; chaque paire de câbles nécessitant un transformateur. **Part E:** tiges en



métal nickelé d'une longueur de 25,5 cm pour fixation des câbles spéciaux soit au plafond soit en coin. **Part F:** écrans résistant à la chaleur s'adaptant sur les éléments 2, 3 et 6. De couleur naturelle, noire.

Part A: Trasformatore bianco con alimentazione 230/125 volt con interruttore, per montaggio a parete o a soffitto. **Part B:** 2 cavi speciali di 6, 8 oppure 10 metri, 4 attacchi murali con tiranti isolati che consentono il montaggio anche su materiali conduttori. **Part D:** 2 x 2 cavi speciali di 6, 8 oppure 10 metri. 4 attacchi murali con tiranti isolati, compresi due isolatori e dispositivo di fissaggio a soffitto. Per entrambi i tratti di cavo è necessario un trasformatore. **Part E:** Aste metalliche nichelate di lunghezza cm. 25,5 per montaggio dei cavi speciali a soffitto oppure ad angolo. **Part F:** Schermi termo-resistenti per gli elementi illuminanti 2, 3 e 6. Disponibili nei colori naturale e nero.

Pieza A: Transformador blanco con entrada de 230/125 voltios con interruptor para montaje en pared o techo. **Pieza B:** 2 cables especiales de 6, 8 o 10 metros, 4 fijaciones a la pared con cierres de sujeción aislados, adecuados también para montar sobre materiales conductores. **Pieza D:** 2 x 2 cables especiales de 6, 8 o 10 metros, 4 fijaciones a la pared con cierres de sujeción aislados, así como dos unidades aislantes y suspensión del techo. Para cada longitud parcial se precisa un transformador. **Pieza E:** Varillas metálicas niqueladas de 25,5 cm de longitud para colgar del techo o pasar sobre una esquina los cables especiales. **Pieza F:** Pantallas para elementos luminosos 2, 3 y 6. Colores naturales, plata, azul o negro mate.

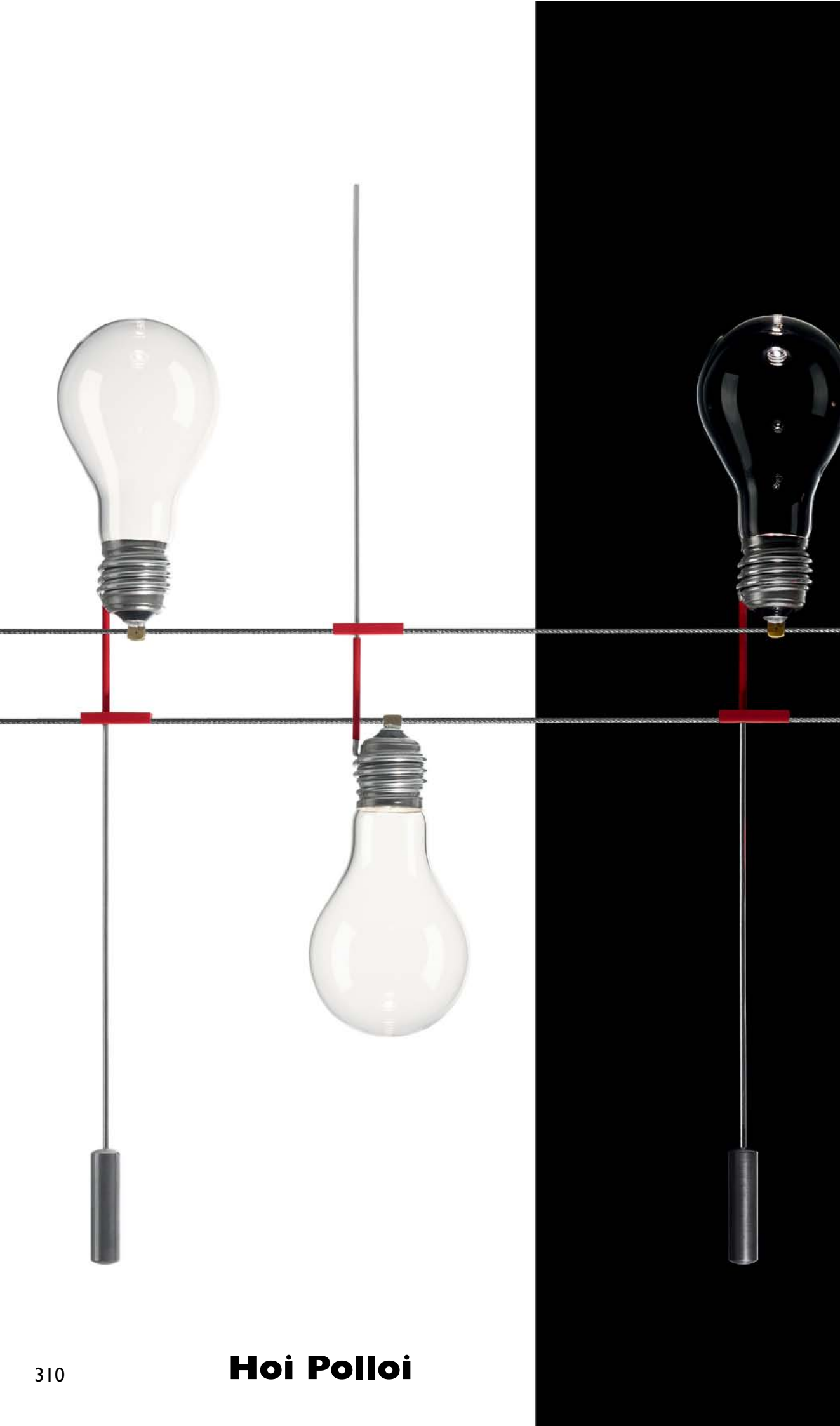


Défilé Issey Miyake, La Villette/Paris



Symphonia Silenziosa, light installation

A composition of custom-made and
standard YaYaHo parts has been realized
for several exhibitions including an
Issey Miyake fashion show in Paris, 1999.





A new low-voltage lighting system using the LED WoonderLux bulb.
Today, still a prototype, tomorrow ...?

**What did we
do with halogen
lighting?**

We stripped it to its bones, respecting function and aesthetics, avoiding visual noise, adding formal expression, thus becoming birds, moons, flying somethings, on wires. Plagiarists have never understood what we did.

**Qu'avons-nous
fait avec l'éclairage
halogène?**

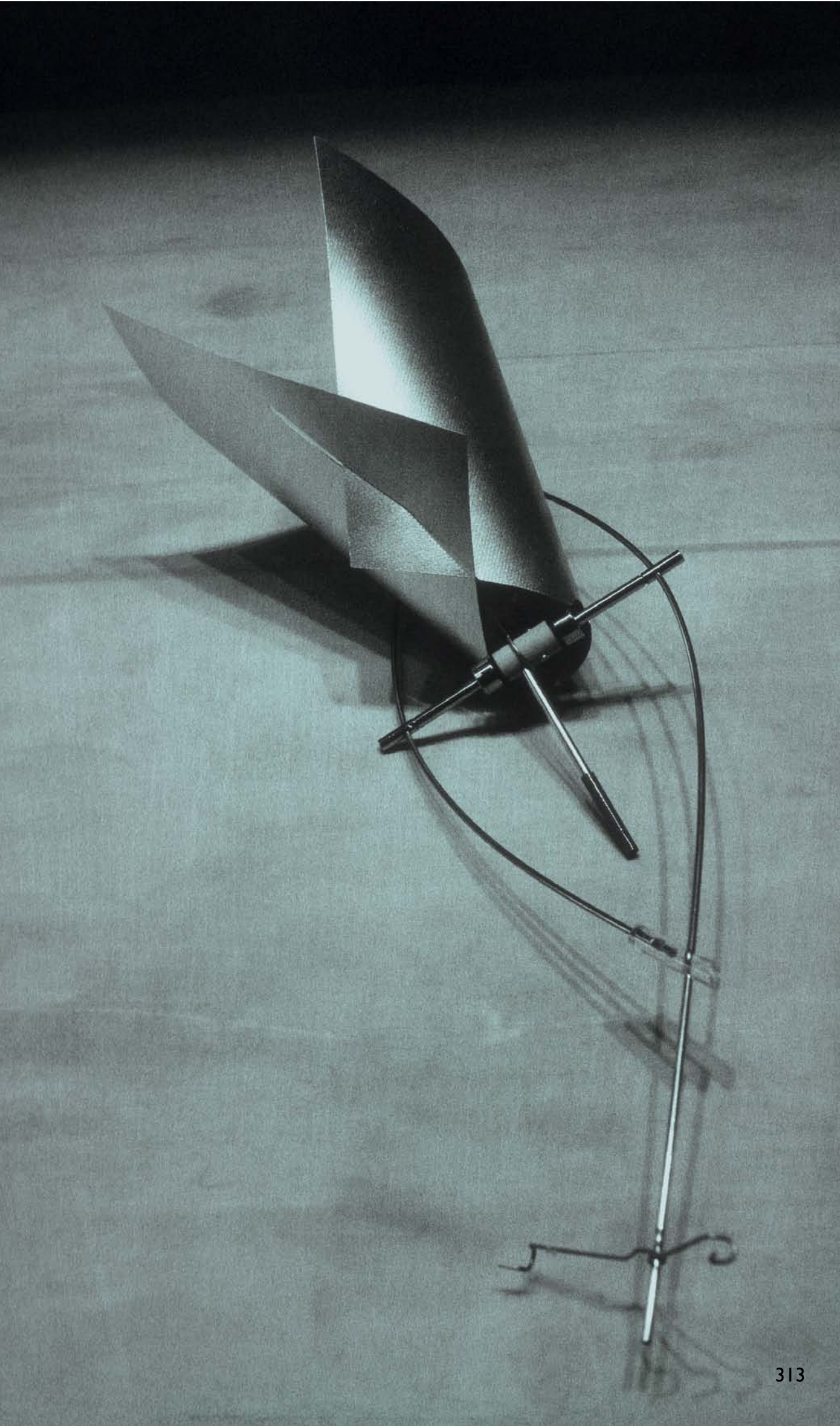
Nous l'avons dénudé jusqu'à l'os, en respectant la fonction et l'esthétique, en évitant le bruit visuel, en ajoutant une expression formelle, le transformant ainsi en oiseaux, lunes, objets volants sur des fils. Les plagiaires n'ont jamais compris ce que nous avons fait.

**Cosa abbiamo fatto
con l'illuminazione
alogeno?**

L'abbiamo ridotta all'essenziale, rispettando funzionalità ed estetica, evitando disarmonie, aggiungendo nuove forme e quindi creato uccelli, lune ed altri oggetti che volano sui cavi. I plagiaristi ciò non l'hanno mai compreso.

**Was haben wir mit
Halogenbeleuchtung
getan?**

Wir reduzierten auf das Notwendigste, haben Funktion und Ästhetik im Auge behalten, visuellen Nonsense vermieden, Formen hinzugefügt und damit Vögel, Monde und andere fliegende Objekte auf Seilen geschaffen. Unsere Plagiatoren haben das nie begriffen.





BaKa RÚ Design: Ingo Maurer und Team 1986

BaKa RÚ ist ein Niedervolt-Lichtsystem und wird über einen Transformator betrieben, der 230/125 Volt auf 12 Volt reduziert. Der Transformator ist mit einer Thermo-sicherung ausgestattet. Er ist bis max. 200 Watt belastbar.

Kunststoff, Metall, Keramik, Multi Mirror-Reflektoren mit Schutzglas. Lieferung mit hitzebeständigen naturfarbenen Blenden, Leuchtmitteln, Bohrschablone und Spannwerkzeug. Die Lichtelemente lassen sich in jede Richtung drehen und auf den Seilen verschieben. Durch die isolierten Spannschlösser ist die Montage auch auf leitenden Materialien möglich. Die Spezialseile können in einer Länge von 6, 8 oder 10 Metern geliefert werden. Bei größeren Distanzen wird ein zweiter Transformator mit den erforderlichen Isolier-einheiten empfohlen. Maximale Belastbarkeit der Seile 350 Watt. Schwarze Blenden erhältlich. Lichtsteuerung nur über Spezialdimmer für Trafobetrieb. BaKaRú lässt sich von Wand zu Wand spannen oder an die Decke montieren. Waagerechte, senkrechte oder auch diagonale Installation ist möglich.



BaKa...Rú is a low-voltage lighting system fed by a transformer which reduces the 230/125-volt mains current to 12 volts. The transformer (max. capacity 200 watts) is fitted with a thermal fuse.

Plastic, metal, ceramic, Multi-Mirror reflectors with protective glass cover. Complete with heat-resistant shades (colour: natural), bulbs, drilling template and cable-tautener. The lighting elements can be moved along the cables and turned in any direction. The insulated tensioning bolts make it possible to install the system on any surface, including conductive materials. The special cables can be supplied in lengths of 6, 8 or 10 m. For longer cables the use of a second transformer (with the necessary insulators) is recommended. Maximum capacity of cables: 350 watts. Shades in black are available. N.B. the dimmer (if any) must be specially adapted for halogen lighting. BaKaRú is equally suitable for wall or ceiling installation. It can be mounted horizontally, vertically or even on the diagonal.



BaKa...Rú est un système d'éclairage basse tension, relié à un transformateur qui change les 230/125 volts en 12 volts. Le transformateur est équipé d'un fusible thermo-électrique. La capacité maximum du transformateur est de 200 watts.

Matière plastique, métal, céramique; réflecteurs Multi Mirror avec verre protecteur. Livré avec des écrans de couleur naturelle résistant à la chaleur, ampoules, gabarit de perçage et tendeurs. Les éléments lumineux sont orientables dans toutes les directions et peuvent être déplacés sur les câbles. Les tendeurs isolants permettent même un montage sur des matériaux conducteurs. Les câbles spéciaux sont livrés dans les longueurs de 6, 8 ou 10 mètres. Pour des distances plus grandes, l'utilisation d'un deuxième transformateur avec les parties isolantes nécessaires est recommandée. Capacité maximum des câbles 350 watts. Ecrans noirs disponibles. Réglage de l'intensité lumineuse uniquement par un variateur spécial pour lampe halogène. BaKaRú se tend de mur à mur ou au plafond. Le système se monte à l'horizontale, mais également à la verticale ou même en diagonale.

BaKa...Rú è un sistema di luci a basso voltaggio, alimentato da un trasformatore che riduce 230/125 volt a 12 volt. Il trasformatore è dotato di una sonda termica. Carico massimo consentito del trasformatore 200 watt.

Materiale sintetico, metallo, ceramica; riflettori Multi Mirror con vetro di protezione. Fornito con schermi termoresistenti di colore naturale, lampadine, dima di foratura e utensili per il montaggio. Gli elementi sono orientabili in ogni direzione e possono essere spostati sui cavi. I tiranti isolati consentono il montaggio anche su materiali conduttori. I cavi speciali sono disponibili nelle lunghezze di 6, 8 e 10 metri. In caso di distanze superiori, è consigliato l'impiego di un secondo trasformatore con l'utilizzo di isolatori. Carico massimo dei cavi 350 watt. Sono disponibili schermi di colore nero. Regolazione della luce esclusivamente mediante uno speciale variatore per lampade alogene. BaKaRú può essere teso da parete a parete o montato a soffitto. E' possibile un'installazione orizzontale, verticale o diagonale.

BaKa...Rú es un sistema de iluminación de bajo voltaje alimentado a través de un transformador, que reduce de 230/125 voltios a 12 voltios. El transformador está equipado con un cortacircuito térmico. Resiste hasta un máx. de 200 vatios.

Plástico, metal, cerámica, reflectores Multi Mirror con cristal protector. Suministrada con pantallas termoestables de colores naturales, bombillas, plantilla de taladrado y elementos de sujeción. Los elementos de iluminación pueden ser girados en todas las direcciones y desplazados hacia los laterales. Los tensores aislados permiten un montaje aún sobre materiales conductores. Los cables especiales están disponibles en medidas de 6, 8 ó 10 metros. En caso de distancias mayores, se recomienda un segundo transformador con las unidades de aislamiento necesarias. Valor límite de los cables 350 vatios. Pantallas negras están disponibles. La difusión de la luz se logra únicamente a través de un regulador especial apto para la operación con transformadores. BaKaRú puede ser tensado de pared a pared o instalado en el techo. Posibles posible un montaje horizontal, vertical o también en diagonal.

Technische und formale Änderungen vorbehalten. Unsere Website bietet weitere Fotos, Skizzen und aktuelle Informationen. Die in diesem Katalog gedruckten Farben können von den tatsächlichen Farben der Lampen abweichen. Wir führen ein großes Spektrum von Ersatzteilen für unsere Produkte. Bitte wenden Sie sich an Ihren lokalen Händler, die zuständige Vertretung oder direkt an die Ingo Maurer GmbH.

We reserve the right to all make technical or aesthetic modifications. Our website offers more images and detailed up-to-date information. Please allow for colour discrepancies between the illustrations in this catalogue and the actual products. We carry a large range of spare parts for our products. Please contact your local dealer, your agency or Ingo Maurer GmbH.

Sous réserve de modifications techniques et de forme. Notre site internet vous propose davantage de photos, d'esquisses et d'informations détaillées et actuelles. Les couleurs imprimées dans ce catalogue peuvent varier des couleurs réelles des lampes. Nous avons une grande variété de pièces détachées pour nos produits. Veuillez contacter votre revendeur local, votre agent ou la société Ingo Maurer GmbH directement.

Salvo modifiche di carattere tecnico o formale. Il nostro sito offre ulteriori fotografie, dettagli e informazioni aggiornate. I colori riprodotti nel catalogo possono differire dai colori reali delle lampade. Offriamo una vasta gamma di ricambi per i nostri prodotti. Per informazioni rivolgersi al vostro rivenditore locale, al vostro agente oppure direttamente alla Ingo Maurer GmbH.

Reservado el derecho de modificaciones técnicas y formales. Nuestra página web le ofrece más fotos, croquis e información actualizada. Los colores impresos en este catálogo y los colores reales de las lámparas pueden diferir. Disponemos de una amplia gama de piezas de repuesto para nuestros productos. Por favor, diríjase a su vendedor local, al representante responsable o directamente a Ingo Maurer GmbH.

| | |
|--|----------------------|
| Geschäftsleitung: | Oswald Schneider |
| Ingo Maurer | Hagen Sczech |
| Jenny Lau | Michel Sempels |
| Joachim Moyzischewitz | Simone Sinhuber |
| Angela Wilhelm | Hana Stauss |
| | Zorka Stosic |
| | Flavia Thumshirn |
| Design, Entwicklung, Planung, Produktion, Vertrieb: | Agustin Trejo |
| | Evangelia Tsaoussi |
| Marion Ackmann | Frideriki Tzafas |
| Ralf Altermann | Sebastian Utermöhlen |
| Viktor Antonijevic | Ferratti Valerio |
| Till Armbrüster | Isagani Vengco |
| Hakim Askia | Florian Vogel |
| Werner Berthold | Peter Wachowich |
| Aissa Bouakkaz | Jenny Weber |
| Albert Brandmair | Hans Weber |
| Reinhold Brandmair | Regina Wilhelm |
| Winfried Brecheler | Uli Wilhelm |
| Marilyn O. F. Cassidy | Angelika Wipf |
| Sylvie Chevalier | Eugen Wronek |
| Herman Cooke | |
| Birget Daenell | |
| Bernhard Dessecker | |
| Heike Dewald | |
| Stella Doerner | |
| Gertraud Eisenreich | |
| Magna Angela Ferreira | |
| Petra Fleissner | |
| Angela Guevara | |
| Rudi Gundel | |
| Thomas Happel | |
| Haki Haxhiu | |
| Sebastian Hepting | |
| Elke Herpich | |
| Odetta Jurkschat | |
| Manfred Kaiser | |
| Friederike Klesper | |
| Matthias Kohlhund | |
| Christa Kolenc | |
| Gabi Kümmerlin | |
| Vassilios Lianos | |
| Matthias Liedtke | |
| Dimitra Lionda | |
| Eveline Lotteraner | |
| Emilija Lotze | |
| Claude Maurer | |
| Eric McNeil | |
| Maria Mettke | |
| Thomas Mettler | |
| Elvira Müllerleile | |
| Christian Muscheid | |
| Ivica Nestic | |
| Petra Obermaier | |
| Harrison Paras | |
| Cveta Pesevska | |
| Manuela Pesevska | |
| Tobias Reischle | |
| Axel Schmid | |

Photographie:

Tom Vack, München

Studio Azzurro, Milano

Nomi Baumgartl, München

Antoine Bootz, New York

Stefan Büchner, Hahnbach

Hans Buttermilch, München

Peter Cook, London

Domus, Milano – Donato di Bello

Bernhard Dessecker, München

Robert Fischer, München

Eric Laignel, New York

Tim Lehmacher, New York

Giovanna Piemonte, Rom

Christof Piepenstock, München

Jonathan B. Ragle, New York

Hagen Sczech, München

Markus Tollhopf, Hamburg

Sebastian Utermöhlen, München

Peter Wachowich, Vancouver

Grafik Design/Realisierung:

Frank Koschembar/www.gute-kommunikation.com

Koordination:

Claude Maurer, Hagen Sczech, Peter Wachowich

Druck:

Sellier Druck GmbH, Freising

Bildbearbeitung/Compositing:

Stefan Geisbauer, red-light-design.com

Ingo Maurer GmbH

Kaiserstrasse 47

80801 München

Tel. +49 89 381 6060

Fax +49 89 381 606 20

info@ingo-maurer.com

Ingo Maurer LLC

89 Grand Street

New York, NY 10013

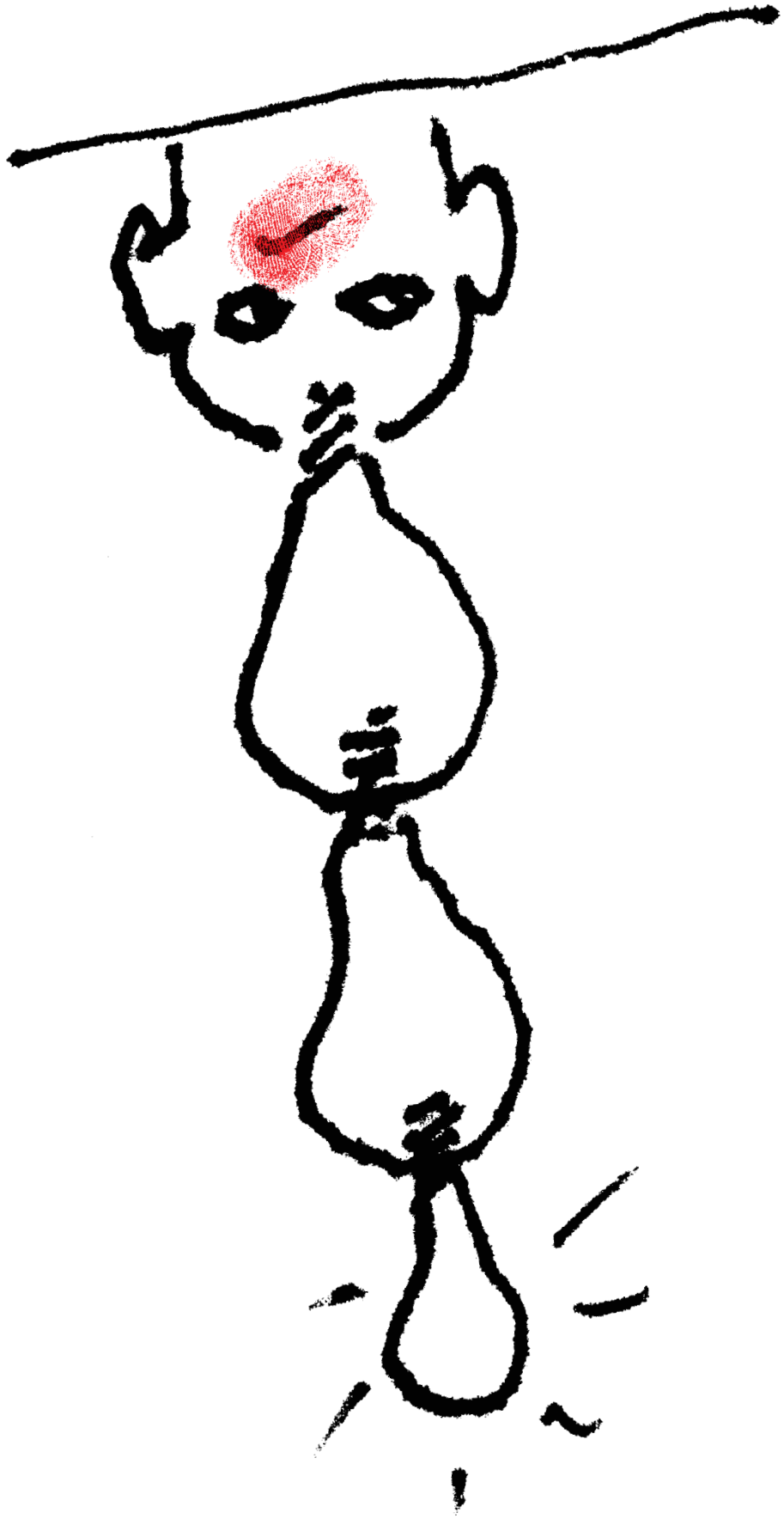
Tel. 212 965 8817

Fax 212 965 8819

making-light@ingomaurer-usa.com

www.ingo-maurer.com

WHO MATUREZ



We believe in teamwork.